



• 全国统一客服热线:
Unified national customer service hotline

400-000-8533

天津市一标阀门制造有限公司

地址: 天津市宝坻区京津新城工业区
电话: 022-26798533
传真: 022-26798534
邮编: 300240
网址: www.tjybfm.com

TIANJIN YIBIAO VALVE MANUFACTURING CO.,LTD.

Add: Jingjin New Town Industrial Zone, Baodi District, Tianjin
Tel: 022-26798533
Fax: 022-26798534
P.C: 300240
http: //www.tjybfm.com

- 一标阀门版权所有, 翻印必究;
- 图片仅供参考, 恕不另行通知, 请用户按图索制样本;
- 一标阀门拥有最新专利;
- 采用先进数字技术;

© 2008 一标阀门 版权所有 TEL: 022-26798533



一
标
阀
门

YIBIAO VALVE

控
制
阀
选
型
样
本

Control valve selection sample



控制阀选型样本

Control valve selection sample



天津市一标阀门制造有限公司
TIANJIN YIBIAO VALVE MANUFACTURING CO.,LTD.



企业简介

BRIEF INTRODUCTION

天津市一标阀门制造有限公司是一家集设计、开发、制造和经营为一体的专业性调节阀企业。自创办以来，始终坚持以质量求生存，以科技产品求发展，经过多年的发展，以其过硬的产品质量和完整的服务体系，获得了广大用户的好评，在行业内树立了良好的企业形象，品牌知名度逐年攀升。

公司拥有精良的设备，采用先进的制造工艺，完善的检测手段，生产能力强大。公司主导产品有：电动调节阀、气动调节阀、精小型调节阀、三通调节阀、自力式调节阀、CV3000系列调节阀、V型调节阀、O型调节阀、快速切断阀、电气动调节阀、电气动调节蝶阀、电气动隔膜阀等自控阀门系列产品。产品广泛应用于电力、石油、化工、制药、冶炼、造纸、纺织、供水供暖等生产工艺管路的自动化控制系统中。

在激烈的市场竞争中，我们坚持科技兴企方针，不断优化产品结构，实施质量改进。还能满足您的特殊需要，如高温高压调节阀，低温调节阀，小流量调节阀，智能调节阀，可实现数字通讯、在线故障诊断、报警等，以及耐腐蚀调节阀，防空化调节阀等，并提供控制阀的长期配套服务。公司产品覆盖面日趋扩大，销售网络遍及全国29个省市自治区、东南亚、中东及欧美地区。

开拓进取、锐意创新是本公司的企业精神，提供优质的产品和满意的服务是我公司的宗旨。热忱欢迎广大客户垂询惠顾！

Tianjin yibiao valve manufacturing co.,ltd. Is a set design, development, manufacturing and operation as one of the professional valve enterprise. Since its establishment, always adhere to the quality of survival, technology products for development, after years of development, with its excellent product quality and complete service system, and won the praise from the broad masses of users, in the industry establish a good corporate image, brand awareness rising year by year.

The company has sophisticated equipment, advanced manufacturing technology, perfect detection means, strong production capacity. The company main products are: electric control valve, pneumatic control valve, refined small regulator, tee regulator, self type valve, CV3000 series valve, V type valve, O type valve, rapid cut-off valve, electric pneumatic control valve, electric pneumatic adjustment butterfly valves, electric pneumatic diaphragm valve and control valve series products. The products are widely used in electric power, petroleum, chemical industry, pharmacy, metallurgy, paper making, textile, water heating and other production process line of automation control system.

In the fierce market competition, we insist on science and technology policy of decoration, and constantly optimize the product structure, implementation of quality improvement. Can also meet your special needs, such as high temperature high pressure valve, low temperature control valve, small flow control valve, intelligent regulator, which can realize digital communication, online fault diagnosis, alarm, etc., and corrosion control valve, air defense change regulator, etc., and provide control valve long-term supporting services. Company product coverage and the increasing, the sales network spreads the nation 29 provinces, cities and autonomous regions, southeast Asia, the Middle East and Europe and America.

Pioneering and enterprising, innovation is our company's enterprise spirit, provides the high quality product and satisfactory service is our company's tenet. Warmly welcome the masses of customers for more patrons!

前言

preface



调节阀属于自动化仪表中的执行器大类。它作为过程控制中的终端元件，随着自动化程度的不断提高，已日益广泛应用于冶金、电力、化工、石油、轻纺、造纸、建材等工业部门中。调节阀安装在现场，直接与介质接触，使用条件恶劣，它的质量和可靠性不仅影响调节品质，而且还涉及到系统的安全、维护人员的安全和环境污染等重大问题，不少场合迫切要求实现自动控制，却常因调节阀不能满足现场要求而无法实现。随着调节阀的发展，人们对调节阀的重要性有了新的认识。要正确可靠地用好调节阀，除产品本身质量外，还与计算、选型、维护、使用密切相关。为此，相关人员必须了解一些调节阀的应用理论，懂得计算、选型、安装、维护、故障诊断和处理等一系列应用知识。为合理、正确选择调节阀作以下几点阐述：

Regulating valve belongs to the automation instrument of the actuator categories. It as process control of the terminal device, with the continuous improvement of the degree of automation, has increasingly widely used in metallurgy, electric power, chemical industry, petroleum, textile, paper, building materials, and other industrial sectors. Valve installed in the scene, direct contact with the media, the use of conditions, it not only affects the quality and reliability of control quality, but also involves the safety of the system and the maintenance personnel's safety and environmental pollution and so on major issues, many occasions urgently need to achieve automatic control, but often for regulating valve can not meet the requirements and can not be achieved. With the development of the control valve, people to the importance of the regulating valve a new understanding. To correct and reliable with good regulating valve, in addition to the product itself quality outside, still and calculation, selection, maintenance, use closely related. Therefore, related personnel must understand some of the regulating valve application theory, know how to calculation, selection, installation, maintenance, fault diagnosis and treatment and so on a series of application knowledge. For reasonable and proper valve for the following paper:

调节阀的选择重点：1.结构先进，2.选材要合理，3.制造精密，4.严格的检测
Regulating valve choice key: 1.Advanced structure, 2.Select material to reasonable, 3.Manufacturing precision, 4.Strict test

调节阀的选型过程：填写参数表—选择控制机构、类型、材料与压力等级—CV值计算—确定流量特性—确定阀出口流速、开度、噪音水平—确认阀门口径—确认阀门内件材料—确认填料与垫片材料—选择执行机构—确认泄漏等级—确认所需附件—填写规格书。

Regulating valve selection process:
Fill in the parameter list and select control mechanism, types, materials and pressure rating, CV value calculation to determine the flow characteristics to determine valve exit velocity, opening, noise level to confirm that the valve calibre – confirm valve internals material – confirm packing and gasket materials to choose and construct execution confirmation leakage level needed to confirm attachment to fill in the specification.

调节阀的选择要素：Regulating valve selection elements:

- 1、工艺条件、可靠性、安全性、操作性能：①闪蒸和空化、气蚀；②压差的考虑；③材料考虑；④从结构上考虑；⑤磨损；⑥腐蚀；⑦高温容易产生高温蠕变；⑧低温产生：脆化；⑨粘性流体；⑩堵塞；
1.process conditions, reliability, security and performance:①the flash and cavitation, cavitation, ②the pressure difference consideration; ③.material consideration; ④.from the structure consideration; ⑤.wear; ⑥.corrosion; ⑦.high temperature easy to produce the high temperature creep; ⑧.cryogenic generation; turn off; ⑨.viscous fluid; ⑩.blocked;
- 2、各种调节阀的结构特点：①单座直通调节阀；②双座阀；③波纹管密封阀；④隔膜阀；⑤小流量单座阀；⑥套筒阀（笼式阀）；⑦带侧装的直通阀；⑧底装阀；⑨三通阀；⑩角型阀；⑪高压阀；⑫偏心旋转阀；⑬球阀；⑭蝶阀；⑮低温冷控制阀；⑯滑板阀；
2. all kinds of valve structure features:①the single seat through regulating valve; ②.the two-seater valve;③bellows seal valve;④.the diaphragm valve; ⑤.small flow single seat valve; ⑥.sleeve valve (cage valve); ⑦.the cage with single seat valve; ⑧.low noise valve; ⑨.three-way valve; ⑩.Angle type valve; ⑪.high-pressure valve; ⑫.eccentric rotary valve; ⑬.ball valve; ⑭.butterfly valve; ⑮.cryogenic cryogenic valve; ⑯.slide valve;
- 3、作用方式的选择：①气开式（故障关）；②气关式（故障开）；
3. mode of action choice: ①the gas open (fault closed); ②the gas off type (fault open);
- 4、流量特性的选择：①等百分比；②直线型；③快开；
4. flow characteristic choice: ①the percentage etc; ②the linear type;③quick opening;
- 5、流量系数口径的选择：①Qmax(最大流量)Qmin (最小流量)；②ΔP压差；③Kv max最大值、Kv min最小值；④流量系数的选用；⑤开度的核算；⑥R可调比的核算；⑦阀座直径；⑧阀门口径的选择；
5. flow coefficient caliber choice: ①Qmax (maximum flow) Qmin (minimum flow); ②ΔP differential pressure; ③Kv Max maximum, Kv min minimum; ④the selection of flow coefficient; ⑤the opening of choking;⑥R adjustable ratio calculation; Indirectly affect the valve;⑦seat diameter; Valve diameter choice;
- 6、材料的选择，十分重要，根据介质不同选用不同材料
6. the choice of materials, is very important, according to the different media choose different materials
- 7、压力等级的选择 7、 pressure rating choice
- 8、泄漏等级的选择 8、 leakage level choice
- 9、噪音的考虑 9、 noise consideration
- 10、填料的选择 10、 selection of filling materials
- 11、防止气蚀破坏 11、 prevent cavitation damage
- 12、附件的选择：①定位器；②电磁阀；③限位开关；④阀门变送器；⑤保位阀；
12. accessories choice: ①the locator; ②the electromagnetic valve; ③limit switch; ④the valve transmitter; ⑤the position valve;

执行机构的选择要素：①驱动能源：分为气动、电动、液动；②阀门类型的考虑（直行程、角行程）；③输出力和输出力矩的考虑；④结构型式考虑；⑤选型目标（结构先进、维修方便、性能可靠、产品质量、售后服务、性价比）；

Actuator selection elements: ①drive energy: divided into pneumatic, electrical, fluid movement; ②.the valve type consideration (straight stroke, angular travel); ③.the output power and output torque, the consideration; ④.the structure types of consideration; ⑤.selection target (advanced structure, convenient maintenance, reliable performance, product quality, the post-sale service, the price);



目录
directory

气动调节阀系列 Pneumatic control valve series	001
ZJHP精小型气动单座调节阀 ZJHP fine small pneumatic single seat valve	002-004
ZJHM精小型气动套筒调节阀 ZJHM fine small pneumatic sleeve valve	005-007
CV3000系列HTS单座调节阀 CV3000 series HTS single seat valve	008-011
CV3000系列HCB笼式双座调节阀 CV3000 series HCB cage two-seater regulator	012-016
CV3000系列HLS小口径单座调节阀 CV3000 series HLS small single seat valve	017-018
CV3000系列HLC小口径套筒调节阀 CV3000 series HLC red sleeve valve	019-020
CV3000系列HSC笼式单座调节阀 CV3000 series HSC cage single seat valve	021-024
CV3000系列HPS高压单座调节阀 CV3000 series HPS high single seat valve	025-028
CV3000系列TCB笼式双座调节阀 CV3000 series TCB cage two-seater regulator	029-031
CV3000系列HPC高压笼式调节阀 CV3000 series HPC high pressure cage control valve	032-034
ZHAN精小型气动薄膜直通双座调节阀 ZHAN fine small pneumatic film through two-seater regulator	035-036
ZH $\frac{1}{2}$ S精小型气动薄膜角形调节阀 ZH $\frac{1}{2}$ S fine small pneumatic film Angle valve	037-038
ZM $\frac{1}{2}$ T-10型气动薄膜隔膜调节阀 ZM $\frac{1}{2}$ T-10 type pneumatic film diaphragm valve	039-040
ZM $\frac{1}{2}$ P(N)-16D型气动薄膜低温调节阀 ZM $\frac{1}{2}$ P(N)-16D type pneumatic film low temperature control valve	041-042
ZMA $\frac{1}{2}$ 型气动薄膜三通调节阀 ZMA $\frac{1}{2}$ type pneumatic film three-way valve	043-045
ZSJP型精小型气动活塞式单座调节阀 ZSJP type fine small pneumatic piston type single seat valve	046-048
ZSJM型精小型气动活塞式套筒调节阀 ZSJM type fine small pneumatic piston sleeve valve	049-051
ZMA $\frac{1}{2}$ B型气动薄膜保温夹套调节阀 ZMA $\frac{1}{2}$ B type pneumatic film insulation jacketed regulator	052-054
ZMA $\frac{1}{2}$ B型气动薄膜波纹管调节阀 ZMA $\frac{1}{2}$ B type pneumatic film bellows valve	055-056
电动调节阀系列 Electric control valve series	057
T940H-100电动给水回转式调节阀 T940H-100 electric water rotary valve	058
T94 $\frac{1}{2}$ H电动调节阀 T94 $\frac{1}{2}$ H electric control valve	059-060
T947H型电动调节阀 T947H type electric control valve	061-062
T94 $\frac{1}{2}$ H型电动调节阀 T94 $\frac{1}{2}$ H type electric control valve	063-064
QSL $\frac{1}{2}$ 型智能型电动调节阀 QSL $\frac{1}{2}$ type intelligent electric control valve	065-066
智能型电动套筒调节阀 Intelligent electric set of Jane regulator	067-068
ZAZP型电动直通单座调节阀 ZAZP type electric through single seat valve	069-070
ZAZN型电动直通双座调节阀 ZAZN type electric through two-seater regulator	071-072
ZAZM型电动套筒调节阀 ZAZM type electric sleeve valve	073-074
ZAZ $\frac{1}{2}$ 型电动三通合流(分流)调节阀 ZAZ $\frac{1}{2}$ type electric tee junction (split) regulating valve	075-076
ZAZS型电动角形调节阀 ZAZS type electric Angle valve	077-078
ZDLP型电子式电动单座调节阀 ZDLP type electronic electric single seat valve	079-081
ZDLN型电子式电动双座调节阀 ZDLN type electronic electric two-seater regulator	082-084
ZDLM型电子式电动套筒调节阀 ZDLM type electronic electric sleeve valve	085-086
ZDLQ、ZDLX型电子式电动三通调节阀 ZDLQ、ZDLX type electronic electric 3-way regulating valve	087-088
ZKZY小流量单座调节阀、ZKZP单座调节阀、ZKZN双座调节阀 ZKZY small flow single seat valve, ZKZP single seat valve, ZKZN two-seater regulator	089-091
ZAZT、ZAZTC型电动隔膜调节阀 ZAZT, ZAZTC type electric diaphragm valve	092-093
调节阀球阀系列 Regulating ball valve series	094
ZDJR、ZKJR、Q941F系列电动O型调节阀 ZDJR、ZKJR、Q941F series of electric type O regulating ball valve	095
ZSHV、ZSSV系列气动V型调节阀 ZSHV、ZSSV series pneumatic V-type regulating ball valve	096
ZSHV、ZSSV系列气动V型球阀 ZSHV、ZSSV series pneumatic V ball valve	097-098
电动三通O型球阀 Electric t O type ball valve	099-100
气动三通O型球阀 Pneumatic t O type ball valve	101-102



目录
directory

切断阀系列 Cut-off valve series	103
ZSHR、ZSHO系列气动O型切断球阀 ZSHR、ZSHO series pneumatic O-type cutting ball valve	104-106
电动O型衬氟切断球阀 Electric O-type lining fluoride cutting ball valve	107-108
气动衬氟O型切断球阀 Pneumatic lining fluoride O-type cutting ball valve	109-110
ZS $\frac{1}{2}$ W3系列气动三维偏心调节切断蝶阀 ZS $\frac{1}{2}$ W3 series pneumatic 3 d eccentric adjustment to cut off the butterfly valve	111-112
ZSPQ型气动活塞切断阀 ZSPQ type pneumatic piston cut-off valve	113-116
ZQGP型气动快速切断阀 ZQGP type pneumatic rapid cut-off valve	117-118
ZM $\frac{1}{2}$ Q(M)气动薄膜切断阀、气动薄膜三通切断阀 ZM $\frac{1}{2}$ Q(M)Pneumatic film cut-off valve, pneumatic film tee cut-off valve	119-120
调节蝶阀系列 Adjustment butterfly valve series	121
ZDLW电子式电动调节蝶阀 ZDLW electronic electric adjustment butterfly valve	122-125
ZAJW型电动调节蝶阀 ZAJW type electric adjustment butterfly valve	126-128
ZKJW $\frac{1}{2}$ -0.1G $\frac{1}{2}$ 型电动高温蝶阀 ZKJW $\frac{1}{2}$ -0.1 G $\frac{1}{2}$ type electric high temperature butterfly valve	129-131
ZKJW $\frac{1}{2}$ -0.1 G $\frac{1}{2}$ 型电动高温蝶阀 ZKJW $\frac{1}{2}$ -0.1 G $\frac{1}{2}$ type electric high temperature butterfly valve	132-133
ZS $\frac{1}{2}$ Vb-0.05型手动百叶窗调节阀 ZS $\frac{1}{2}$ Vb-0.05 type manual shutter window valve	134-137
DYF系列电动圆板阀 DYF series of electric circular plate valve	138-139
手动调节阀系列 Manual control valve series	140
手动调节阀、自锁手动调节阀 Manual control valve, self-locking manual control valve	141
给水回转式调节阀 Feed rotary valve	142
自力式压力调节阀系列 Self type pressure regulating valve series	143
自力式调节阀概述 Self type valve overview	144
自力式压力(差压)调节阀 Self type pressure (differential) control valve	145-150
指挥器操作型自力式压力调节阀 Command device operational self type pressure regulator	151-153
自力式流量调节阀 Self type flow control valve	154-157
自力式压力、差压组合阀(压力、差压上升阀) Self type pressure, differential pressure combination valve (pressure, differential pressure rise valve shut)	158-160
自力式流量、温度组合阀 Self type flow, temperature combination valve	161
自力式组合调节阀 Self type combination valve	162-163
ZZYP型自力式压力调节阀 ZZYP type self type pressure regulator	164-165
ZZYPR-16B软密封自力式阀后压力调节阀 ZZYPR-16B soft seal self type valve after pressure regulator	166-167
ZZVP-16B型自力式微压调节阀 ZZVP-16B type self decline pressure regulator	168-171
ZZDQ型氮封装置 ZZDQ type nitrogen seal	172-176
ZZYP-250B型自力式减压阀 ZZYP-250B type self type pressure reducing valve	177-179
ZWT自力式温度调节阀 ZWT self type temperature control valve	180-181
ZZWPE自力式电控温度调节阀 ZZWPE self type electric temperature regulator	182
直接作用压力调节阀 Direct action pressure regulator	183
附件与附录 Accessories and appendix	184
3810L、3810R 电子式电动执行器 3810L、3810R electronic electric actuator	185
电动执行机构 Electric actuators	186
ZH $\frac{1}{2}$ 型气动薄膜精小型执行机构 ZH $\frac{1}{2}$ pneumatic film fine small actuator	187
DYR角行程 DYR Angle stroke	188
RT型气动执行器 RT type pneumatic actuator	189-191
HEP系列电-气阀门定位器 HEP series electric-pneumatic valve positioner	192
YT-1000系列电气阀门定位器 YT-1000 series electric valve positioner	193
QFH型系列空气过滤器 QFH type series air filter	194
限位开关 Limit switch	195
调节阀流量系数计算 Regulating valve flow coefficient calculation	196-197
气体的性质表 The properties of the gas table	198
液体的性质表 The nature of the liquid table	199
材料选用表 Material selection table	200-202



气动调节阀系列

Pneumatic control valve series

ZJHP精小型气动单座调节阀

ZJHP fine small pneumatic single seat valve

概述

ZJHP型气动单座调节阀由气动多弹簧薄膜执行机构和低流阻单座阀组成，新型执行机构高度低、重量轻、装校简便，新型阀体结构紧凑、流通通畅，具有大的流量系数。

本产品操作稳定，具有可靠的动作特性，微小的阀座泄露、精确的流量特性、宽大的可调范围等特点。它必将以独特的优点在广泛应用中取得高质量的控制效果。

产品符合GB/T4213-1992。

Overview

ZJHP type pneumatic single seat valve by pneumatic many spring diaphragm actuator and low flow resistance single seat valve composition, new actuator height, light weight, low loading school is simple, new body structure compact, Runner unobstructed, with large flow coefficient.

This product operation stability, reliable action characteristics, small seat disclosure, accurate flow characteristics, wide adjustable range etc. It will bring to the unique advantages in a wide range of applications Achieve high quality control effect.

Products comply with GB/T4213-1992.

主要技术参数和性能指标 The main technical parameters and performance index

调节机构主要技术参数 Regulatory agency main technical parameters

公称通径(mm) Nominal diameter	20		25	40	50	65	80	100	150	200					
阀座直径(mm) Seat diameter	10	12	15	20	25	32	40	50	65	80	100	125	150	200	
额定流量系数KV Rated flow coefficient	直线 Linear	1.8	2.8	4.4	6.9	11	17.6	27.5	44	69	110	176	275	440	690
	等百分比 Equal percentage	1.6	2.5	4	6.3	10	16	25	40	63	100	160	250	400	630
公称压力(MPa) Nominal pressure	0.6 1.6 4.0 6.4														
行程mm stroke	10		16	25		40		60							
流量特性 Characteristics	直线、等百分比 Linear, Equal percentage														
介质温度℃ Medium temperature	-15-200、-40-250(常温型)、-40-450(中温型) -15-200、-40-250(Cold type)、-40-450(Medium temperature type)														
法兰尺寸 Flange size	铸钢法兰尺寸按JB78, 铸钢法兰尺寸按JB79 Cast iron flange size according to JB78, cast steel flange dimension regulation according to JB79														
法兰型式 Flange type	法兰密封面按JB77, 其中铸钢法兰按光滑式, 铸钢法兰按凹式 Flange sealing surface type according to JB77, including cast iron flange according to smooth type, cast steel flange by concave type														
阀体材质 Body material	PN	0.6,1.6													
	(MPa)	4.0,6.4													
阀芯材质 Valve core material	1Cr18Ni9、0Cr18Ni12Mo2Ti														
上盖型式 Bonnet type	普通式(常温型)、热片式(中温型) Common type (cold type), hot plate (medium temperature type)														
可调比R Rangeability	50:1														
气源接头 Air joint	M16 x 1.5														

注：可为用户提供ANSI、API、JIS等国外法兰标准的产品，结构长度也可按用户需要确定。
Note: can provide users with ANSI, API, JIS and other foreign flange standard products, structure length the user can also be need to make sure.

执行机构主要技术参数 Actuator main technical parameters

型号 Type	ZHA/ZHB-22	ZHA/ZHB-23	ZHA/ZHB-34	ZHA/ZHB-45
有效面积cm ² Effective area	350	350	560	900
行程mm stroke	16	25	40	60
弹簧范围KPa Spring range	20-100(标准); 40-200; 80-240; 20-60; 60-100 20-100(standard); 40-200; 80-240; 20-60; 60-100			

性能指标 Performance index

项目 project		指标值 Index value	项目 project	指标值 Index value		
基本误差% Basic error	不带定位器 Don't take locator	± 5.0			气关 Gas shut	始点 Initial point
	带定位器 Belt locator	± 1.0	终点 end	± 2.5		
回差% Return difference	不带定位器 Don't take locator	≤ 3.0	气开 Gas open	始点 Initial point		± 1.0
	带定位器 Belt locator	≤ 1.0		终点 end		± 1.0
死区% Dead zone	不带定位器 Don't take locator	≤ 3.0		允许泄漏量L/h Allow leakage	始点 Initial point	± 2.5
	带定位器 Belt locator	≤ 0.4			终点 end	± 1.0
额定行程偏差% Rated stroke deviation		± 2.5	1 × 10 ⁻⁴ × 阀额定容量 Valve rated capacity			

允许压差 Allow differential pressure

执行机构型式 Actuator type	执行机构型号 Actuator model	弹簧范围 KPa Spring range	气源压力 KPa Air pressure	需要附件 Accessories	公称口径(阀座直径)mm Nominal diameter (seat diameter)																		
					20				25		40		50		65		80		100		150		200
					(10)	(12)	(15)	(20)	25	(32)	(40)	50	65	80	100	(125)	(150)						
气关 Gas shut	ZHA-22	20-100 20-100 40-200	140 250 400	P P P或R	6.4 6.4 6.4	6.4 6.4 6.4	5.94 6.4 6.4	3.34 6.4 6.4	2.14 6.4 6.4														
	ZHA-23	20-100 20-100 40-200	140 250 400	P P P或R																			
	ZHA-34	20-100 20-100 40-200	140 250 400	P P P或R																			
	ZHA-45	20-100 20-100 40-200	140 250 400	P P P或R															0.22 1.02 1.39	0.15 0.71 0.97	0.08 0.40 0.54		
气开 Gas open	ZHB-22	20-100 40-200 80-240	140 250 400	P P P或R	4.46 6.4 6.4	3.09 6.4 6.4	1.98 5.94 6.4	1.1 3.34 6.4	0.71 2.14 4.99														
	ZHB-23	20-100 40-200 80-240	140 250 400	P P P或R																			
	ZHB-34	20-100 40-200 80-240	140 250 400	P P P或R																			
	ZHB-45	20-100 40-200 80-240	140 250 400	P P P或R																			

注: 1.P—阀门定位器; R—压力继动器。
2.允许压差为阀关闭P2=0状态下, ΔP的最大值。
3.最大压差超过1.0MPa, 阀盖、阀座表面堆焊硬质合金或改用其它材料。
Note: 1. The P - valve positioner, R - pressure servomotor.
2. Allow differential pressure for valve closed P2 = 0 condition, maximum of ΔP.
3. Maximum differential pressure more than 1.0 MPa, plug, seat surfacing carbide or to switch to other materials.

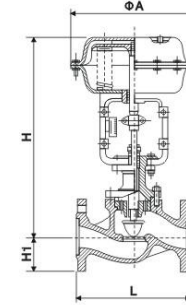

可配附件 Can match accessories

定位器、手轮机构、空气过滤减压器等。Locator, hand wheel mechanism, air filtration pressure reducer, etc.

外形尺寸 Physical size

DN	L			普通 ordinary	高温 High temperature	H				H1				重量(Kg) weight		Φ A	
	PN ⁶ ₁₆	PN40	PN64			PN6	PN16	PN40	PN64	PN6	PN16	PN40	PN64	PN6	PN16		PN40
20	184	194	206	398	548	45		52		65	19	23					285
25	185	197	210	410	560	50		57		70	20	24					
32	200	210	220	418	578	56		70		78	24	31					360
40	222	235	251	455	620	65		75		85	26	35					
50	254	267	286	475	627	70		82		90	30	40					470
65	276	292	311	610	790	80		92		102	47	66					
80	298	317	337	622	807	95		100		107	55	78					580
100	352	368	394	640	850	105	110	117		125	65	99					
125	410	425	440	864	1122	120	125	135		148	120	140					
150	451	473	508	870	1130	132	142	150		175	130	160					
200	600	620	650	890	1150	160	170	187		207	175	250					
250	650	670	690	1203	1523	187	202	225		235	350	470					
300	740	770	800	1234	1554	220	230	257		265	500	670					

主要零件材料 The major parts material

零件名称 Part name	材料 material	温度范围 Temperature range	备注 note
阀体上阀盖 Body bonnet	HT200	-15~200℃	
	WCB	-20~425℃	
	ZG1Cr18Ni9Ti	-40~550℃	
	ZG0Cr18Ni12Mo2Ti	-40~600℃	
阀芯、阀座 Valve core, valve seat	1Cr18Ni9	-40~550℃	
	0Cr18Ni12Mo2Ti	-40~550℃	
填料 packing	聚四氟乙烯 teflon	-40~200℃	
膜片 diaphragm	丁腈橡胶夹增强涤纶织物 Nitrile rubber clamping reinforced polyester fabric		
压缩弹簧 Compression spring	60Si2Mn		
膜盖 Membrane cover	A3		

订货须知

订货时请填写《规格书》或注明以下内容:
1. 产品型号 2. 公称压力 3. 公称口径、额定流量系数Kv 4. 信号压力、弹簧范围 5. 流量特性 6. 阀的开关方式 7. 介质工作温度范围 8. 阀体、阀芯材料 9. 是否带附件, 说明附件型号 10. 是否有其它特殊要求

Order instructions

When ordering, please fill in (specification) or indicate the following contents:
1. product model 2. Body ratings 3. nominal diameter, rated flow coefficient Kv 4. signal pressure, spring range 5. flow characteristics 6. the flow characteristic of the valve switch mode 7. medium operating temperature range 8. the valve body, valve core material 9. whether or not to bring a accessories, explain accessories model 10. of whether any other special requirements



ZJHM精小型气动套筒调节阀 ZJHM fine small pneumatic sleeve valve

概述

ZJHM型气动套筒调节阀形小、体轻、高性能、大容量，是符合IEC标准的新一代通用调节阀产品。它广泛应用于石化、轻纺等行业中一般流体介质和工艺条件且安装空间紧凑的自动控制系统。

本产品由新型的气动多弹簧薄膜执行机构和低流阻套筒阀组成。

产品符合GB/T4213-1992。

特点如下:

- 1.采用平衡型阀芯，不平衡力小，允许压差大，操作稳定。
- 2.阀芯导向面大，可改善由涡流和冲击引起的振荡，并减少损坏。
- 3.比普通单双座调节阀噪声降低10dB左右。
- 4.结构简单，装卸维修方便。

Overview

ZJHM type pneumatic sleeve valve shape of small, light weight, high performance, large capacity, it is accord with IEC standard of a new generation of general valve products. It is widely used in petrochemical, textile and other industry in general fluid medium and process conditions and the installation space compact automatic control system.

This product by the new type of pneumatic many spring diaphragm actuator and low flow resistance of sleeve valve.

Products comply with GB/T4213-1992.

Features below:

1. The use of balanced type valve core, unbalanced force is small, allow differential pressure big, operation stability.
2. Valve core guide surface big, can improve the eddy current and the impact caused by the oscillation, and to reduce damage.
3. Than ordinary single seat valve noise reduction 10 dB or so.
4. Simple structure, loading and convenient maintenance.

主要技术参数和性能指标 The main technical parameters and performance index

调节机构主要技术参数 Regulatory agency main technical parameters

公称直径(mm) Nominal diameter	25	40	50	65	80	100	150	200			
阀座直径(mm) Seat diameter	25	32	40	50	65	80	125	150	200		
额定流量系数KV Rated flow coefficient	直线 Linear	11	17.6	27.6	44	69	110	176	275	440	690
	等百分比 Equal percentage	10	16	25	40	63	100	160	250	400	630
公称压力(MPa) Nominal pressure	0.6 1.6 4.0 6.4										
行程mm stroke	16	25	40					60			
流量特性 Characteristics	直线，等百分比 Linear, Equal percentage										
介质温度℃ Medium temperature	-15-200、-40-250(常温型)Cold type、-40-450(中温型)Medium temperature type -15-200、-40-250(Cold type)、-40-450(Medium temperature type)										
法兰尺寸 Flange size	铸钢法兰尺寸按JB78，铸钢法兰尺寸按JB79 Cast iron flange size according to JB78, cast steel flange dimension regulation according to JB79										
法兰型式 Flange type	法兰密封面按JB77，其中铸钢法兰按光滑式，铸钢法兰按凹式 Flange sealing surface type according to JB77, including cast iron flange according to smooth type, cast steel flange by concave type										
阀体材料 Body material	PN	0.6,1.6									
	(MPa)	4.0,6.4									
阀芯材料 Valve core material	1Cr18Ni9、0Cr18Ni12Mo2Ti										
上阀盖型式 Bonnet type	普通式(常温型)，热片式(中温型) Common type (cold type), hot plate (medium temperature type)										
可调比R Rangeability	50:1										

注：可为用户提供ANSI、API、JIS等国外法兰标准的产品，结构长度也可按用户需要确定。
Note: can provide users with ANSI, API, JIS and other foreign flange standard products, structure length the user can also be need to make sure.

执行机构主要技术参数 Actuator main technical parameters

型号 Type	ZHA/ZHB-22	ZHA/ZHB-23	ZHA/ZHB-34	ZHA/ZHB-45
有效面积cm ² Effective area	350	350	560	900
行程mm stroke	16	25	40	60
弹簧范围KPa Spring range	20-100(标准); 40-200; 80-240; 20-60; 60-100 20-100(standard), 40-200, 80-240, 20-60, 60-100			

ZJHM精小型气动套筒调节阀 ZJHM fine small pneumatic sleeve valve



性能指标 Performance index

项目 project	指标值 Index value	项目 project	指标值 Index value	
基本误差% Basic error	不带定位器 Don't take locator	气关 Gas shut	始点 Initial point	
	带定位器 Belt locator		终点 end	
回差% Return difference	不带定位器 Don't take locator		气开 Gas open	始点 Initial point
	带定位器 Belt locator			终点 end
死区% Dead zone	不带定位器 Don't take locator	允许泄漏量L/h Allow leakage		始点 Initial point
	带定位器 Belt locator			终点 end
额定行程偏差% Rated stroke deviation	±2.5		2×10 ⁻⁶ × 阀额定容量 Valve rated capacity	

允许压差 Allow differential pressure

开关方式 Switch mode	执行机构型号 Actuator type	弹簧范围 Kpa Spring range	气源压力 Kpa Air pressure	需要附件 Accessories	公称直径(阀座直径)mm Nominal diameter (seat diameter)									
					25	40	50	65	80	100	150	200		
气关 Gas shut	ZHA-22	20-100 20-100 40-200	0.14 0.25 0.4	- P P或R	3.00 6.4 6.4									
	ZHA-23	20-100 20-100 40-200	0.14 0.25 0.4	- P P或R		2.25 6.4 6.4	1.95 6.4 6.4							
	ZHA-34	20-100 20-100 40-200	0.14 0.25 0.4	- P P或R				2.36 6.4 6.4	2.04 6.4 6.4	1.67 6.4 6.4				
气开 Gas open	ZHA-45	20-100 20-100 40-200	0.14 0.25 0.4	- P P或R							1.41 6.4 6.4	1.41 6.4 6.4		
	ZHB-22	20-100 40-200 80-240	0.14 0.25 0.4	- P P或R	1.5 4.5 6.4									
	ZHB-23	20-100 40-200 80-240	0.14 0.25 0.4	- P P或R		1.13 3.38 6.4	0.98 2.93 6.4							
	ZHB-34	20-100 40-200 80-240	0.14 0.25 0.4	- P P或R			1.18 3.54 6.4	1.02 3.06 6.4	0.84 2.51 5.85					
ZHB-45	20-100 40-200 80-240	0.14 0.25 0.4	- P P或R							0.71 2.12 4.94	0.57 1.71 4.00			

- 注：1.P—阀门定位器；R—压力继动器。
2.允许压差为阀关闭P2=0状态下，ΔP的最大值。
3.最大压差超过1.0MPa，阀盖、阀座表面堆焊硬质合金或改用其它材料。

Note: 1. The P - valve positioner, R - pressure servomotor.
2. Allow differential pressure for valve closed P2 = 0 condition, train a maximum ΔP.
3. Maximum differential pressure more than 1.0 MPa, plug, seat surfacing carbide or to switch to other materials.

ZJHM精小型气动套筒调节阀 ZJHM fine small pneumatic sleeve valve

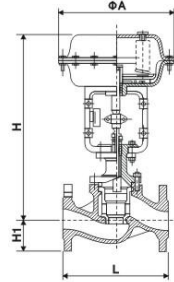

可配附件 Can match accessories

定位器、手轮机构、空气过滤减压器等。Locator, hand wheel mechanism, air filtration pressure reducer, etc.

外形尺寸 Physical size

DN	L			H		H1				重量(Kg) weight		φA
	PN ⁶ ₁₆	PN40	PN64	普通 ordinary	高温 high temperature	PN6	PN16	PN40	PN64	PN6 PN16	PN40 PN64	
20	184	194	206	398	548	45	52	65	19	23	285	
25	185	197	210	410	560	50	57	70	20	24		
32	200	210	220	418	578	56	70	78	24	31		
40	222	235	251	455	620	65	75	85	26	35		
50	254	267	286	475	627	70	82	90	30	40		
65	276	292	311	610	790	80	92	102	47	66		
80	298	317	337	622	807	95	100	107	55	78		
100	352	368	394	640	850	105	110	117	65	99		
125	410	425	440	864	1122	120	125	135	148	140		
150	451	473	508	870	1130	132	142	150	175	160		
200	600	620	650	890	1150	160	170	187	207	250		
250	650	670	690	1203	1523	187	202	225	235	470		
300	740	770	800	1234	1554	220	230	257	265	600		

主要零件材料 The major parts material

零件名称 Part name	材料 material	温度范围 Temperature range	备注 note
阀体上阀盖 Body bonnet	HT200	-15~200℃	
	WCB	-20~425℃	
	ZG1Cr18Ni9Ti	-40~550℃	
	ZG0Cr18Ni12Mo2Ti	-40~600℃	
阀芯、阀座 Valve core, valve seat	1Cr18Ni9	-40~550℃	
	0Cr18Ni12Mo2Ti	-40~550℃	
填料 packing	聚四氟乙烯 teflon	-40~200℃	
膜片 diaphragm	丁腈橡胶夹增强涤纶织物 Nitrile rubber clamp enhance terylen fabric		
压缩弹簧 Compression spring	60Si2Mn		
膜盖 Membrane cover	A3		

订货须知

订货时请填写《规格书》或注明以下内容:

1. 产品型号 2. 公称压力 3. 公称口径、额定流量系数Kv 4. 信号压力、弹簧范围 5. 流量特性 6. 阀的开关方式 7. 介质工作温度范围 8. 阀体、阀芯材料 9. 是否带附件, 说明附件型号 10. 是否有其它特殊要求

Order instructions

When ordering, please fill in 《specification》 or indicate the following contents:

1. product model 2. Body ratings 3. nominal pressure, nominal diameter, rated flow coefficient Kv 4. signal pressure, spring range 5. flow characteristics 6. the flow characteristic of the valve switch mode 7. medium operating temperature range 8. the valve body, valve core material 9. whether or not to bring a accessories, explain accessories model 10. of whether any other special requirements

CV3000系列HTS单座调节阀 CV3000 series HTS single seat valve

概述

HTS单座调节阀, 阀芯采用上导向结构, 阀结构紧凑, 有呈S流线的通道, 使其压降损失小, 流量大, 可调范围宽, 流量特性精度高, 符合IEC534-2标准。

调节阀的泄漏量符合ANSIB16.104的标准。调节阀配用多弹簧薄膜执行机构, 其结构紧凑, 输出力大。

产品符合GB/T4213-92

Overview

HTS single seat valve, valve core is used on guide structure, valve structure is compact, have show S streamline channels, make its pressure drop loss small, large flow, adjustable scope, the flow characteristics of high accuracy, operator Close IEC534-2 standard.

The control valve leakage ANSIB16.104 conform to the standard. Control valve with many spring diaphragm actuator, its structure is compact, large output force.

Products comply with GB/T4213-92

主要技术参数和性能指标 The main technical parameters and performance index

阀体 Body

型式 Type	直通单座铸造球阀 Through single seat casting ball valve	
公称口径(mm) Nominal diameter	40、50、65、80、100、150、200mm	
公称压力(MPa) Nominal pressure	ANSI125、150、300、600 JIS10、16、20、30、40K PN1.6、4.0、6.4MPa	
材料 material	铸钢 (ZG230-450)、铸不锈钢 (ZG1Cr18Ni9Ti、ZG1Cr18Ni12Mo2Ti、ZG0Cr18Ni12Mo2Ti) 等 Cast steel (ZG230-450)、Cast stainless steel (ZG1Cr18Ni9Ti、ZG1Cr18Ni12Mo2Ti、ZG0Cr18Ni12Mo2Ti)	
上 阀 盖 On valve cover	常温型(P) Cold type	-17~+230℃
	伸长I型(E1) Elongation I type	-45~-17℃、+230~+566℃
	伸长II型(E2I) Elongation II type	-100~-45℃
	伸长II型(E2W) Elongation II type	-196℃~-100℃
压盖型式 Gland type	螺栓压盖式 Bolt pressure type	
填料 packing	V型聚四氟乙烯填料、含浸聚四氟乙烯石棉填料、石棉编织填料、石墨填料 V ptfе packing, containing immersion teflon asbestos packing, asbestos braided packing, graphite packing	

注: 工作温度不准超过各种材料的允许范围
Note: working temperature of various materials must not be more than the allowed range

法兰距 Face to Face dimension

公称 口径 (mm) Nominal diameter	A							
	ANSI 125FF、PN1.6 ANSI 150 RF JIS 10K FF, RF	JIS 16K RF	ANSI 300 RF JIS 20、30K RF JIS 30K RF	ANSI 600 RF JIS 40K RF PN6.4	JIS 16K 沟槽型 嵌入型 Groove type Embedded type	JIS 20K 沟槽型 嵌入型 Groove type Embedded type	JIS 30K 沟槽型 嵌入型 Groove type Embedded type	JIS 40K 沟槽型 嵌入型 Groove type Embedded type
40	222	231	235	251	235	236	248	251
50	254	263	267	286	265	267	276	286
65	276	288	292	311	290	292	303	311
80	298	313	317	337	310	317	326	337
100	352	364	368	394	360	368	379	394
150	451	465	473	508	475	473	486	508
200	543	560	568	610	570	568	580	610

Cv值和行程 Cv value and stroke

公称直径(mm) Nominal diameter	40			50			65			80			100			150			200			
阀座直径(mm) Seat diameter	25	32	40	32	40	50	40	50	65	50	65	80	65	80	100	100	125	150	125	150	200	
额定 Cv值 Rated Cv value	高精度阀芯 High precision valve core	10	17	24	17	24	44	24	44	68	44	68	99	68	99	175	175	275	360	275	360	640
	大容量阀芯 High capacity valve core			30			50			85			125			200			420			700
	快开阀芯 Quick-opening valve core			35			55			95			135			220			460			720
额定 行程 (mm) Rated stroke	其它阀芯 Other valve core	25						38						50			75					
	快开阀芯 Quick-opening valve core	10			13			19			25			30			50					

备注：高精度金属阀座流量特性符合IEC534-2
Note: high precision metal seat flow characteristic conforms to the IEC534-2

允许压差 Allow differential pressure

金属阀座柱塞阀芯 Metal seat plunger valve core

阀配用HA或VA执行机构 Valve with HA or VA actuator

气—关式阀 Gas – shut type valve

执行机构 actuator	供气压力 (Mpa) Air supply	弹簧范围 (Mpa) Spring range	定位器 locator	允许压差(MPa) Allow differential pressure											
				公称直径(mm) Nominal diameter											
				25	32	40	50	65	80	100	125	150	200		
HA2D	0.14	0.02-0.10	有或无 Have or No	0.63	0.38	0.27	0.16	0.10	0.07	0.05	-	-	-		
	0.16	0.02-0.10	有 Have	0.36	1.93	1.37	0.78	0.51	0.35	0.20	-	-	-		
	0.40	0.08-0.24	有 Have	4 9.4	4 4.7	4 4.1	2.17	1.49	1.05	0.59	-	-	-		
HA3D	0.14	0.02-0.10	有或无 Have or No	1.12	0.68	0.48	0.28	0.17	0.12	0.07	0.04	0.03	-		
	0.16	0.02-0.10	有 Have	4 5.6	3.42	2.42	1.4	0.88	0.62	0.35	0.22	0.14	-		
	0.40	0.08-0.24	有 Have	4 10	4 10	4 7.2	4 7.2	2.65	1.87	1.05	0.67	0.41	-		
HA4D	0.14	0.02-0.10	有或无 Have or No	-	-	0.83	0.48	0.3	0.22	0.12	0.07	0.05	0.03		
	0.16	0.02-0.10	有 Have	-	-	4	2.42	1.52	1.07	0.61	0.39	0.24	0.15		
	0.40	0.08-0.24	有 Have	-	-	4 10	4 7.2	4 4.5	3.22	1.82	1.16	0.71	0.45		
VA5D	0.14	0.02-0.10	有或无 Have or No	-	-	-	-	0.42	0.29	0.16	0.11	0.06	0.04		
	0.16		有 Have	-	-	-	-	2.08	1.47	0.83	0.53	0.32	0.21		

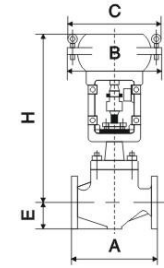

配HA执行机构
Match HA actuator

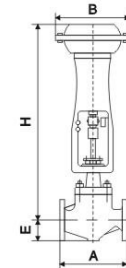

配HA5执行机构
Match HA5 actuator

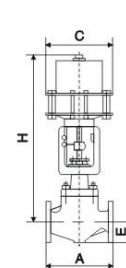

配HA6执行机构
Match HA6 actuator

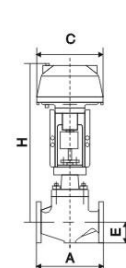

配VP执行机构
Match VP actuator

气—开式阀 Gas – open valve

执行机构 actuator	供气压力 (Mpa) Air supply	弹簧范围 (Mpa) Spring range	定位器 locator	允许压差(MPa) Allow differential pressure											
				公称直径(mm) Nominal diameter											
				25	32	40	50	65	80	100	125	150	200		
HA2R	0.14	0.12-0.10	有或无 Have or No	0.63	0.38	0.27	0.16	0.10	0.07	0.05	-	-	-		
	0.28	0.08-0.24	有 Have	4.0 4.4	2.7	1.41	1.11	0.69	0.49	0.28	-	-	-		
HA3R	0.14	0.12-0.10	有或无 Have or No	1.12	0.68	0.48	0.28	0.17	0.12	0.07	0.04	0.03	-		
	0.28	0.08-0.24	有 Have	4.0 7.8	4.0 4.7	3.4	1.96	1.23	0.87	0.49	0.31	0.19	-		
HA4R	0.14	0.12-0.10	有或无 Have or No	-	-	0.84	0.48	0.30	0.22	0.12	0.07	0.05	0.03		
	0.28	0.08-0.24	有 Have	-	-	4.0 5.8	3.15	2.13	1.5	0.85	0.54	0.33	0.21		
VA5R	0.14	0.12-0.10	有或无 Have or No	-	-	-	-	0.42	0.29	0.17	0.11	0.06	0.04		
	0.28	0.08-0.24	有 Have	-	-	-	-	2.92	2.06	1.16	0.74	0.45	0.29		
VA6R	4*(1)	0.19-0.35	有 Have	-	-	-	-	4.0 6.1	4.0 4.3	2.42	-	-	-		
	5*(2)	0.19-0.40	有 Have	-	-	-	-	-	-	2.42	1.55	0.95	-		

备注：1、深色框内数字表示阀配用标准规格执行机构。
2、最大允许压差不超过ANSI B16.34或JIS B2201标准规定的最大值。
3、同一格内上方数字为阀全开时允许压差，下方数字为阀关闭时的允许压差。
4、*1适用于DN65、80、100mm的阀，*2适用于DN150mm的阀。
Note: 1. dark frame in digital representation valve with standard specifications actuator.
2. the maximum allowable pressure difference no more than ANSI B16.34 or JIS B2201 standard maximum.
3. the same cell number above for valve fully open allows a pressure differential, below digital for valve closing allow differential pressure.
4. *1 is applicable to DN65, 80, 100 mm valve, *2 applicable to DN150mm valve.



CV3000系列HTS单座调节阀
CV3000 series HTS single seat valve

Cv值和行程 Cv value and stroke

公称直径(mm) Nominal diameter	执行机构 actuator	H				C	φB	E
		P	E1	E2				
				E2I	E2W			
40	HA2D, R	500	665	780	1020	281	267	70
	HA3D, R	590	760	875	1140	363	350	
50	HA2D, R	500	670	785	1025	281	267	80
	HA3D, R	595	765	875	1140	363	350	
65	HA2D, R	575	745/755	880	1130	281	267	88
	HA3D, R	630	800/810	930	1180	363	350	
	HA4D, R	865	1035/1045	1165	1495	520	470	
80	HA2D, R	580	755/765	900	1135	281	267	98
	HA3D, R	635	810/820	955	1190	363	350	
	HA4D, R	870	1045/1055	1190	1505	520	470	
100	HA2D, R	610	810/870	915	1150	281	267	113
	HA3D, R	680	860/870	1020	1205	363	350	
	HA4D, R	890	1100/1110	1255	1520	520	470	
	VA5D	1300	1515	1710	1940	-	620	
	VA5R	1420	1635	1820	2050	-	620	
	VA6R	1160	1375	1560	1790	-	445	
	VP5	940	1155	1340	1570	-	345	
150	HA3D, R	785	1020/1045	1250	1385	363	350	170
	HA4D, R	955	1190/1215	1425	1570	520	470	
	VA5D	1360	1620	1870	2000	-	620	
	VA5R	1480	1740	1980	2110	-	620	
	VA6R	1220	1480	1720	1850	-	445	
	VP5	1000	1260	1500	1630	-	345	
	VP6	1210	1470	1710	1840	-	445	
200	VP7	1290	1550	1790	1920	-	545	220
	HA4D, R	1090	1350	1580	1710	520	470	
	VA5D	1475	1740	2025	2155	-	620	
	VA5R	1585	1850	2145	2275	-	620	
	VP6	1165	1425	1665	1795	-	345	
	VP6	1375	1635	1875	2005	-	445	
	VP7	1455	1715	1955	2085	-	-	

备注: 1. P=常压型, E1=伸长 I 型, E2=伸长 II 型, E2 I =整体式, E2W=焊接式。

2. 表上H栏尺寸是调节阀不带手轮机构的数值, 如果要加上手轮机构的尺寸, 查HA执行机构的技术参数表编号NO.AN10-29-2。

3. 伸长 I 型E1栏尺寸, 左边数字为JIS 10K和ANSI 125, 150的阀, 右边数字为JIS 16K和ANSI 300以上的阀。

Note: 1. P = cold type, E1 = elongation I type, E2 = elongation II type, E2 I = monolithic, E2W = welding type.

2. and table on H column size is regulating valve without the handwheel mechanism of numerical, if take top loading wheel mechanism, then to the corresponding plus the handwheel mechanism size, check HA actuator technology Parameter table Numbers NO. AN10-29-2.

3. elongation I type E1 column size, the left number for JIS 10K and ANSI 125, 150 valve, the right number for JIS 16K and ANSI more than 300 valve.



CV3000系列HCB笼式双座调节阀
CV3000 series HCB cage two-seater regulator

HCB笼式双座调节阀是一种压力平衡式的调节阀, 筒体流体通道呈S流绕型, 还设有一个改善套筒周围流体平稳流动的导流翼, 优点是压降损失小, 流量大, 可调范围宽, 流量特性曲线精度高, 动态稳定性好, 噪音低, 空化腐蚀小。
调节阀配用多弹簧式薄膜执行机构, 结构紧凑, 输出力大。适宜控制高温, 低温的高压差流体。
产品符合GB/T4213-1992。

HCB cage two-seater valve is a kind of pressure balance type valve, body fluid channel is S streamline, there is also a improve sleeve surrounding fluid smooth flow of the fin, the advantage is pressure drop a small loss, large flow, adjustable scope, the flow characteristic of high accuracy, good dynamic stability, low noise, cavitation corrosion small.

Control valve with many spring type diaphragm actuator, compact structure, large output force. Appropriate control high temperature, low temperature high differential pressure fluid.

Products comply with GB/T4213-1992.

技术参数和性能 Technical parameters and performance

阀体 Body		直通双座铸球型阀 Through two seater casting ball valve	
型式 Type		直通双座铸球型阀 Through two seater casting ball valve	
公称直径(mm) Nominal diameter		40-200mm	
公称压力(MPa) Nominal pressure		ANSI 125, 150, 300, 600 JIS 10, 16, 20, 30, 40k PN1.6, 4.0, 6.4MPa	
材料 material		Ht200 ZG25 ZG1Cr18Ni9 ZG0Cr17Ni12Mo2 1.25Cr0.5Mo 5.0Cr0.5Mo SCPH21 SCPH61 TI	
连接型式 Connection type	法兰式 flange	FF, RF, RJ, LG	
	标准 standard	按ANSI B16.5; JIS B2201 JB/T79.1 PN1.6MPa, JB/T79.2 凹凸面	
上阀盖 On valve cover	焊接式 welded	对接焊BW(40-50mm) 对焊BW(65-200mm) Scarft weldingBW(40-50mm) Butt weldingBW(65-200mm)	
	常压型(P) Temperature type	-17~+230℃	
伸长 I 型(E1) Elongation I type	伸长 I 型(E1)	-45~+17℃ +230~+566℃	
	伸长 II 型(E2) Elongation II type	整体式(E2I): -100~-45℃ 焊接式(E2W): -196~-100℃ monolithic(E2I): -100~-45℃ welded(E2W): -196~-100℃	
压紧型式 Gland type		螺栓压紧式 Bolt pressure type	
填料 packing		V型聚四氟乙烯填料, 含浸聚四氟乙烯石棉填料, 石棉编织填料。 V pte packing, including dipping teflon asbestos packing, asbestos braided packing.	

阀作用型式 Valve mode of action 附件 accessories 可调范围 Adjustable range: 50:1
气—开式, 气—关式 Gas - open, gas - shut type 定位器、保位阀、手轮机构、气动阀位变送器 etc

执行机构 Actuator

型式 Type	Ha多弹簧式薄膜执行机构 Ha more spring type diaphragm actuator
膜片材料 Diaphragm material	乙丙橡胶夹尼龙 Ethylene propylene rubber clamp nylon
弹簧范围 Spring range	0.02-0.10, 0.08-0.24MPa
供气压力 Gas supply pressure	0.14, 0.16, 0.28MPa
气源接头 Air joint	Rc 1/4
环境温度 Environment temperature	-30~+70℃
备注 note	该阀也可配用VAS和VP执行机构 This valve can also be with VAS and VP actuator

阀内组件 Valve components within

阀芯型式 Valve core type	压力平衡阀芯 Pressure balance type valve core
流量特性 Flow characteristic	高精度流量特性、高容量套筒流量特性 High precision flow characteristic high capacity sleeve flow characteristic
工作范围 Scope of work	软阀座的工作温度和压差、司太莱堆焊的工作温度和压差 Soft seat working temperature and pressure difference company too lai overlaying welding work temperature and pressure difference
备注 note	整体式和分离式套筒应根据以喉口径、材料、工作温度而定 Monolithic and separate sleeve should be based on to say size, materials, working temperature and deolde
材料 material	-17-4PH, 0Cr17Ni12Mo2 司太莱堆焊 Company too lai overlaying welding

性能 performance

泄漏量 leakage	金属阀座 Metal seat	符合标准ANSI B16.104 II 级, 小于额定Cv的0.5% Accord with a standard ANSI B16.104 II level, less than 0.5% of the rated Cv 符合标准ANSI B16.104 IV 级, 小于额定Cv的0.7% (带定位器), 小于额定Cv的0.7% (带开阀) Accord with a standard ANSI B16.104 IV level, less than rated Cv's 0.7% company too lai overlaying the seat. less than rated Cv's 0.7% (with opening valve seat)
回差 Return difference		3%(不带定位器); 1%(带定位器) 3% (without locator); 1% (with locator)
线性 linear		±5%(不带定位器); ±1%(带定位器) ±5% (without locator); ±1% (with locator)
备注 note		采用标准的V型四氟乙烯填料 The standard V tetrafluoroethylene packing

Cv值和行程 Cv value and stroke

公称直径(mm) Nominal diameter	40		50		65		80		100		150		200								
阀座直径(mm) Seat diameter	25	32	40	32	40	50	40	50	65	50	65	80	65	80	100	100	125	150	125	150	200
额定Cv值 Rated Cv value	高容量 High capacity	36		60		100		140		220		420		820							
	等百分比 Equal percentage	40		75		110		150		240		435		850							
高精度套筒 High precision sleeve	11	17	24	17	24	44	24	44	68	44	68	99	68	99	175	175	275	360	275	360	650
额定行程(mm) Rated stroke	25				38				50				75								

备注：高精度金属阀座流量特性符合IEC534-2
Note: high precision metal seat flow characteristic conforms to the IEC534-2

允许压差 Allow differential pressure

金属阀座 Metal seat

气—关式阀 Gas — shut type valve

执行机构 actuator	供气压力 (Mpa) Gas supply pressure	弹簧范围 (Mpa) Spring range	定位器 locator	允许压差(MPa) Allow differential pressure						
				公称直径(mm) Nominal diameter						
				40	50	65	80	100	150	200
HA2D	0.14	0.02~0.10	有或无 Have or No	0.99	0.77	0.66	0.54	0.42	-	-
	0.16	0.02~0.10	有 Have	4 4.92	3.8	3.29	2.74	2.08	-	-
	0.40	0.08~0.24	有 Have	4 10	4 10	4 9.87	4 9.23	4 6.28	-	-
HA3D	0.14	0.02~0.10	有或无 Have or No	1.75	1.37	1.17	0.97	0.74	0.52	-
	0.16	0.02~0.10	有 Have	4 8.7	4 6.7	4 5.8	4 4.87	3.7	2.61	-
	0.40	0.08~0.24	有 Have	4 10	4 10	4 10	4 10	4 10	4 7.86	-
HA4D	0.14	0.02~0.10	有或无 Have or No	-	-	2.02	1.67	1.28	0.90	0.74
	0.16	0.02~0.10	有 Have	-	-	4 10	4 8.39	4 6.36	4 4.5	4 3.7
	0.40	0.08~0.24	有 Have	-	-	4 10	4 10	4 10	4 10	4 10



气—开式阀 Gas — open valve

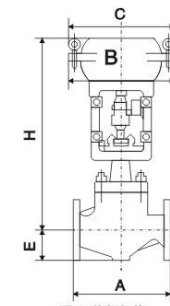

配HA执行机构
Match HA actuator

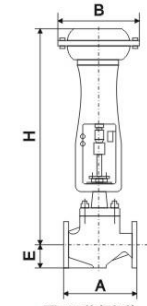

配HA5执行机构
Match HA5 actuator

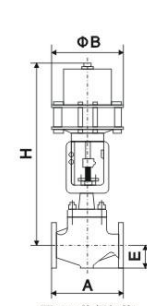

配HA6执行机构
Match HA6 actuator

执行机构 actuator	供气压力 (MPa) Gas supply pressure	弹簧范围 (MPa) Spring range	定位器 locator	允许压差(MPa) Allow differential pressure						
				公称直径(mm) Nominal diameter						
				40	50	65	80	100	150	200
HA2R	0.14	0.02~0.10	有或无 Have or No	0.99	0.77	0.66	0.54	0.42	-	-
	0.28	0.08~0.24	有 Have	4 6.81	4 5.39	4 4.6	3.84	2.93	-	-
HA3R	0.14	0.02~0.10	有或无 Have or No	1.75	1.37	1.17	0.97	0.74	0.52	-
	0.28	0.08~0.24	有 Have	4 10	4 9.57	4 8.17	4 6.8	4 5.18	3.67	-
HA4R	0.14	0.02~0.10	有或无 Have or No	-	-	2.02	1.67	1.28	0.90	0.74
	0.28	0.08~0.24	有 Have	-	-	4 10	4 10	4 8.97	4 6.3	4 5.1
VA5R	0.14	0.02~0.10	有或无 Have or No	-	-	-	-	1.75	1.23	1.02
	0.14	0.04~0.12	有或无 Have or No	-	-	-	-	4 5.2	3.7	3.07
	0.28	0.08~0.24	有 Have	-	-	-	-	4 10	4 8	4 7
VA6R	0.40	0.19~0.35	有 Have	-	-	-	-	4 10	-	-
	0.50	0.19~0.40	有 Have	-	-	-	-	-	4 10	-

备注：1、深色框内数字表示阀配用标准规格执行机构。
2、最大允许压差不超过ANSI B16.34或JIS B2201标准规定的最大值。
3、同一格内上方数字为阀全开时允许压差，下方数字为阀关闭时的允许压差。
Note: 1. dark frame in digital representation valve with standard specifications actuator.
2. the maximum allowable pressure difference no more than ANSI B16.34 or JIS B2201 standard maximum.
3. the same cell number above for valve fully open allows a pressure differential, below digital for valve closing allow differential pressure.

Cv值和行程 Cv value and stroke

公称直径(mm) Nominal diameter	执行机构 actuator	H				C	φB	E
		P	E1	E2				
				E2I	E2W			
40	HA2D, R	500	685	780	1020	281	267	70
	HA3D, R	590	760	875	1140	363	350	
50	HA2D, R	500	670	785	1025	281	267	80
	HA3D, R	595	765	875	1140	363	350	
65	HA2D, R	575	745/755	880	1130	281	267	90
	HA3D, R	630	800/810	930	1180	363	350	
	HA4D, R	865	1035/1045	1165	1495	520	470	
80	HA2D, R	580	755/765	900	1135	281	267	100
	HA3D, R	635	810/820	925	1190	363	350	
	HA4D, R	870	1045/1055	1190	1505	520	470	
100	HA2D, R	610	810/820	915	1150	281	267	115
	HA3D, R	660	860/870	1020	1205	363	350	
	HA4D, R	890	1100/1110	1255	1520	520	470	
	VA5D	1420	1635	1820	2050	-	620	
150	VA5R	1160	1375	1560	1790	-	445	170
	HA3D, R	785	1020/1045	1250	1385	363	350	
	HA4D, R	955	1190/1215	1425	1570	520	470	
	VA5D	1480	1740	1980	2110	-	620	
	VA5R	1220	1480	1720	1850	-	445	
200	HA4D, R	1090	1350	1580	1710	-	470	220
	VA5D	1585	1850	2145	2275	-	620	

备注：1、P=常温型，E1=伸长Ⅰ型，E2=伸长Ⅱ型，E2I=整体式，E2W=焊接式。

2、表上H尺寸是调节阀不带手轮机构的数值，如果带顶装手轮机构，那么要相应加上手轮机构的尺寸，查HA执行机构的技术参数表编号NO.AN10-29-2。

3、伸长Ⅰ型E1尺寸，左边数字为JIS 10K和ANSI 125, 150的阀，右边数字为JIS 16K和ANSI 300以上的阀。

Note: 1. P = cold type, E1 = elongation I type, E2 = elongation II type, E2 I = monolithic, E2 W = welding type.

2. and table on H column size is regulating valve without the handwheel mechanism of numerical. If take top loading wheel mechanism, then to the corresponding plus the handwheel mechanism size, check HA actuator technology Parameter table Numbers NO. AN10-29-2.

3. elongation I type E1 column size, the left number for JIS 10 K and ANSI 125, 150 valve, the right number for JIS 16K and ANSImore than 300 valve.

法兰距 Face to Face dimension

公称直径(mm) Nominal diameter	A							
	ANSI 125FF, PN1.6 ANSI 150 RF JIS 10K FF, RF	JIS 16K RF	ANSI 300 RF JIS 20, 30K RF JIS 30K RF	ANSI 600 RF JIS 40K RF PN6.4	JIS 16K 沟槽型 嵌入型 Groove type Embedded type	JIS 20K 沟槽型 嵌入型 Groove type Embedded type	JIS 30K 沟槽型 嵌入型 Groove type Embedded type	JIS 40K 沟槽型 嵌入型 Groove type Embedded type
40	222	231	235	251	235	236	248	251
50	254	263	267	286	265	267	276	286
65	276	288	292	311	290	292	303	311
80	298	313	317	337	310	317	326	337
100	352	364	368	394	360	368	379	394
150	451	465	473	508	475	473	486	508
200	543	560	568	610	570	568	580	610

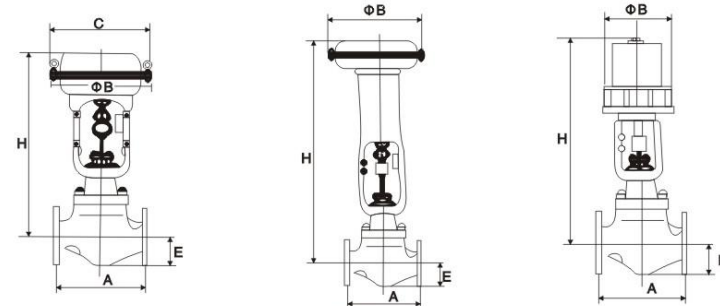

法兰距及外形尺寸
Flange distance and external dimensions

法兰距 Face to Face dimension

公称直径(mm) Nominal diameter	A							
	ANSI 125FF ANSI 150RF JIS 10K FFRF PN1.6	JIS 16K RF	ANSI 300RF JIS 20K RF JIS 30K RF PN4.0	ANSI 600RF JIS 40K RF PN6.4	JIS 16K 沟槽型 嵌入型 Groove type Embedded type	JIS 20K 沟槽型 嵌入型 Groove type Embedded type	JIS 30K 沟槽型 嵌入型 Groove type Embedded type	JIS 40K 沟槽型 嵌入型 Groove type Embedded type
40	222	231	235	251	235	236	248	251
50	254	263	267	286	264	264	276	286
65	276	288	292	311	290	290	303	311
80	298	313	317	337	310	310	326	337
100	352	364	368	394	360	360	379	394
150	451	465	473	508	475	475	486	508
200	543	560	568	610	570	570	580	610

公称直径(mm) Nominal diameter	A						
	ANSI 150 RJ	ANSI 300 RJ	ANSI 600 RJ	ANSI 300 LG	ANSI 600 LG	ANSI 150 SW, BW	ANSI 150, 600 SW, BW
40	235	248	251	244	248	251	251
50	267	283	289	276	283	286	286
65	289	308	314	302	306	311	311
80	311	333	340	327	333	337	337
100	365	384	397	378	391	391	394
150	464	489	511	483	505	473	508
200	556	584	613	578	606	568	610

注：法兰距符合IEC534-3标准
Note: the flange distance conform to the IEC534-3 standard

CV3000系列HLS小口径单座调节阀 CV3000 series HLS small single seat valve

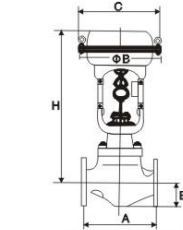

法兰距及外形尺寸
Flange distance and external dimensions

概述

HLS小口径单座调节阀, 结构紧凑, 有呈S流线的通道, 使其压降损失小, 流量大, 可调范围广, 流量特性精度高, 符合IEC534标准。调节阀的泄漏量符合ANSIB16.104的标准。调节阀配用多弹簧薄膜执行机构, 其结构紧凑, 输出力大。产品符合GB/T4213-92

overview

HLS small single seat regulator, compact structure, have show S streamline channels, make its pressure drop loss small, large flow, adjustable scope, the flow characteristics of high accuracy, IEC534 conform to the standard.

The control valve leakage ANSIB16.104 conform to the standard. Control valve with many spring diaphragm actuator, its structure is compact, large output force.

Products comply with GB/T4213-92

技术参数和性能 Technical parameters and performance

阀体 Body

型式 Type	直通单座铸造球阀 Through single seat casting ball valve
公称直径(mm) Nominal diameter	20、25mm
公称压力(MPa) Nominal pressure	ANSI125、150、300、600 JIS10、16、20、30、40K PN1.6、4.0、6.4MPa
材料 material	铸钢 (ZG230-450)、铸不锈钢 (ZG1Cr18Ni9Ti、ZG1Cr18Ni12Mo2Ti、ZG0Cr18Ni12Mo2Ti) 等 Cast steel (ZG230-460)、Cast stainless steel (ZG1Cr18Ni9Ti、ZG1Cr18Ni12Mo2Ti、ZG0Cr18Ni12Mo2Ti)
上阀盖 On valve cover	常温型(P) Cold type -17~+230°C
	伸长I型(E1) Elongation I type -45~-17°C、+230~+566°C
	伸长II型(E2I) Elongation II type -100~-45°C
	伸长II型(E2W) Elongation II type -196°C~-100°C
注: 工作温度不准超过各种材料的允许范围 Note: working temperature of various materials must not be more than the allowed range	
压盖型式 Gland type	螺栓压紧式 Bolt pressure type
填料 Packing	V型聚四氟乙烯填料、含浸聚四氟乙烯石棉填料、石棉编织填料、石墨填料 V pte packing, containing Immersion teflon asbestos packing, asbestos braided packing, graphite packing

外形尺寸 Physical size

单位: mm

执行机构 actuator	H				φB	C	E	A PN1.6 150RF
	常温型P Cold type	伸长I型E1 Elongation I type	伸长II型E2I Elongation II type	伸长II型E2W Elongation II type				
LHA1D、R	375	525	685	900	218	230	40	184
LHA2D、R	450	600	760	975	267	281	40	187

注: 表上H栏尺寸是调节阀不带手轮机构的数字, 如果带手轮机构, 要相应加上手轮机构的尺寸。
Note: list H column size is regulating valve without the handwheel mechanism number, if equipped with a hand wheel mechanism, corresponding with the size of the handwheel institutions.

CV3000系列HLS小口径单座调节阀 CV3000 series HLS small single seat valve

回差: 3%(不带定位器); 1%(带定位器) Return difference: 3% (without locator); 1% (with locator)
线性: ±5%(不带定位器); ±1%(带定位器) Linear: ±5% (without locator); ±1% (with locator)
备注: 采用标准的V型聚四氟乙烯填料 Note: the standard V pte packing

可调范围: 50:1(Cv≤1.0)或30:1(Cv≤0.63) Adjustable range: 50:1(Cv≤1.0)或30:1(Cv≤0.63)

Cv值和行程 Cv value and stroke

阀芯型式 Valve core type	阀座和流量特性 Seat and flow characteristic	行程 stroke	0.01	0.04	0.1	0.16	0.25	0.4	0.63	1.0	1.6	2.5	4.0	6.3	10	14	
柱芯阀芯 Plunger valve core	金属阀座 Metal seat	等百分比(%) Equal percentage					○	△	△	△	△	△	△	△	△	△	
		线性(L) linear	○	○	○	○	○	△	△	△	△	△	△	△	△	△	
	软阀座 Soft seat	等百分比(%) Equal percentage					○	○	○	○	○	○	○	○	○	○	○
		线性(L) linear					○	○	○	○	○	○	○	○	○	○	○
快开阀芯 Quick-opening valve core	司太莱堆焊阀座(QS) Stellite overlaying seat	6.0												○	○		
公称直径(mm) Nominal diameter 20、25			←—————→														

备注: 1、符号△和○表示阀的规格范围, 2、符号△表示阀的流量特性符合IEC534-2标准。
Note: 1, symbol train and ○ said valve specifications range, 2, symbol △ said valve flow characteristics conform to the IEC534-2 standard.

允许压差 Allow differential pressure

金属阀座 Metal seat

作用方式 Mode of action	执行机构 actuator	供气压力 (MPa) Gas supply pressure	弹簧范围 (MPa) Spring range	定位器 locator	允许压差(MPa) Allow differential pressure										
					额定Cv值 Rated Cv value										
					≤0.25	0.40	0.63	1.0	1.6	2.5	4.0	6.3	10	14	
气关式 Gas close type	HA2D	0.14	0.02-0.10	有或无 Have or No	4*	4*	4*	3.26	3.26	2	2	1.09	0.52	0.50	
					10	6.2	6.2								
					有 Have	-	4*	4*	4*	4*	4*	4*	4*	4*	2.52
气开式 Gas open type	HA2R	0.14	0.02-0.10	有或无 Have or No	4*	4*	4*	3.62	3.62	2	2	1.09	0.52	0.50	
					10	6.2	6.2								
					有 Have	-	4*	4*	4*	4*	4*	4*	4*	4*	3.5
气开式 Gas open type	HA2R	0.28	0.08-0.24	有 Have	4*	4*	4*	4*	4*	4*	4*	4*	4*	4*	4*
					10	10	10	10	10	10	10	10	10	10	
					10	10	10	10	10	10	10	10	10	10	10

备注: 1、最大允许压差不超过ANSI B16.34或JIS B2201标准规定的最大工作压力。
2、同一格内上方数字为阀全开时允许压差, 下方数字为阀关闭时的允许压差。
3、带有*的允许压差, 阀控制液体时, 允许压差只能为3MPa, 超过3MPa时, 请选用HLC调节阀。
Note: 1, the maximum allowable pressure difference no more than ANSI B16.34 or JIS B2201 standard maximum working pressure.
2, the same cell number above for valve fully open allows a pressure differential, below digital for valve closing allow differential pressure.
3, marked with * allows pressure difference, valve control liquid, allowing the pressure difference can only for 3 MPa, more than 3 MPa, please choose HLC regulator.

概述

HLC小口径笼式单座调节阀，是一种高性能的调节阀，坚固的阀芯导向和套筒可防止液体发生闪蒸和空化。结构紧凑，有呈S流线的通道，使其压降损失小，流量大，可调节范围广。

调节阀的泄漏量符合ANSIB16.104的标准。调节阀配有多弹簧薄膜执行机构，其结构紧凑，输出力大。

产品符合GB/T4213-92

Overview

HLC small cage single seat valve, it is a kind of high performance valve, strong valve core orientation and sleeve can prevent the liquid happen flash and cavitation. The structure is compact, have show S streamline channels, make its pressure drop loss small, large flow, adjustable range.

The control valve leakage ANSIB16.104 conform to the standard. Control valve with many spring diaphragm actuator, its structure is compact, large output force.

Products comply with GB/T4213-92

技术参数和性能 Technical parameters and performance

阀体 Body

型式 Type	直通单座套筒式铸造球阀 Through single seat cover cylinder casting ball valve		
公称直径(mm) Nominal diameter	20, 25mm		
公称压力(MPa) Nominal pressure	ANSI125、150、300、600 JIS10、16、20、30、40K PN1.6、4.0、6.4MPa		
材料 material	铸钢 (ZG230-450)、铸不锈钢 (ZG1Cr18Ni9Ti、ZG1Cr18Ni12Mo2Ti、ZG0Cr18Ni12Mo2Ti) 等 Cast steel (ZG230-450)、Cast stainless steel (ZG1Cr18Ni9Ti、ZG1Cr18Ni12Mo2Ti、ZG0Cr18Ni12Mo2Ti)		
上阀盖 On valve cover	常温型(P) Cold type	-17~+230℃	
	伸长 I 型(E1) Elongation I type	-45~-17℃、+230~+566℃	
	伸长 II 型(E2I) Elongation II type	-100~-45℃	
	伸长 II 型(E2W) Elongation II type	-196℃~-100℃	
注：工作温度不准超过各种材料的允许范围 Note: working temperature of various materials must not be more than the allowed range			
压盖型式 Gland type	螺栓压紧式 Bolt pressure type		
填料 Packing	V型聚四氟乙烯填料、含浸聚四氟乙烯石棉填料、石棉编织填料、石墨填料 V ptfе packing, containing immersion teflon asbestos packing, asbestos braided packing, graphite packing		

外形尺寸 Physical size

单位: mm

执行机构 actuator	H				φ B	C	E	A PN1.6 150RF
	常温型P Cold type	伸长 I 型E1 Elongation I type	伸长 II 型E2I Elongation II type	伸长 II 型E2W Elongation II type				
LHA1D、R	375	525	685	900	218	230	40	184
LHA2D、R	450	600	760	975	267	281	40	187

注：表上H栏尺寸是调节阀不带手轮机构的数字，如果带手轮机构，要相应加上手轮机构的尺寸。
Note: list H column size is regulating valve without the handwheel mechanism number, if equipped with a hand wheel mechanism, corresponding with the size of the handwheel institutions.

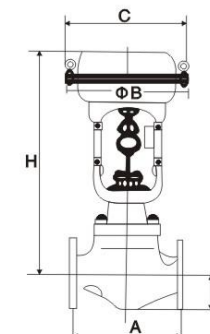

法兰距及外形尺寸
Flange distance and external dimensions

回差: 3%(不带定位器); 1%(带定位器) Return difference: 3% (without locator); 1% (with locator)
线性: ±5%(不带定位器); ±1%(带定位器) Linear: ±5% (without locator); ±1% (with locator)
备注: 采用标准的V型聚四氟乙烯填料 Note: the standard V ptfе packing

可调范围: 50:1 (Cv≤1.0)或30:1 (Cv≤0.63)
Adjustable range: 50:1 (Cv≤1.0)或30:1 (Cv≤0.63)

Cv值和行程 Cv value and stroke

额定Cv值 Rated Cv value		0.01	0.04	0.1	0.16	0.25	0.4	0.63	1.0	2.5	4.0
流量特性 Flow characteristics	金属阀座 Metal seat					○	○	○	○	○	○
	等百分比(%) Equal percentage					○	○	○	○	○	○
	线性(L) linear	○	○	○	○	○	○	○	○	○	○
额定行程(mm) Rated stroke		14.3									
公称直径(mm) Nominal diameter		20, 25									

备注: 1、符号○表示阀的规格范围。 Note: 1、symbol ○ said valve specifications range.

允许压差 Allow differential pressure

执行机构 actuator	供气压力 (MPa) Gas supply pressure	弹簧范围 (MPa) Spring range	定位器 locator	允许压差(MPa) Allow differential pressure						
				额定Cv值 Rated Cv value						
				≤0.25	0.40	0.63	1.0	1.6	2.5	4.0
HA2D (HA2R)	0.14	0.02-0.10	有或无 Have or No	4 10	4 6.2	4 6.2	3.26	3.26	2	2
	0.16 (0.28)	0.02-0.10 (0.08-0.24)	有 Have	- 10	4 10	4 10	4 10	4 10	4 10	4 10

备注: 1、最大允许压差不超过ANSI B16.34或JIS B2201标准规定的最大工作压力。

2、同一格内上方数字为阀全开时允许压差，下方数字为阀关闭时的允许压差。

3、括号内为反作用执行机构的值。

Note: 1、the maximum allowable pressure difference no more than ANSI B16.34 or JIS B2201 standard maximum working pressure.
2、the same cell number above for valve fully open allows a pressure differential, below digital for valve closing allow differential pressure.
3、The brackets for reaction actuator value.



CV3000系列HSC笼式单座调节阀 CV3000 series HSC cage single seat valve

HSC笼式单座调节阀是一种高性能的单座调节阀，适用于高压差产生闪蒸空化的场合，坚固的套筒保护阀体不受闪蒸和空化的破坏。阀体流体通道呈S流线性，压降损失小，流量大，可调节范围广。

阀芯导向面积大，抗振性好。调节阀配用弹簧式薄膜执行机构，结构紧凑，输出力大。
产品符合GB/T4213-1992。

HSC cage single seat valve is a kind of high performance single seat valve, it is suitable for high differential pressure produce flash cavitation occasions, strong sleeve to protect the body from flash and cavitation damage, body fluid channel is S streamline, pressure drop loss small, large flow, adjustable range.

Valve core to find large area, vibration resistance is good. Control valve with spring type diaphragm actuator, compact structure, large output force.

Products comply with GB/T4213-1992.

技术参数和性能 Technical parameters and performance

阀体 Body

型式 Type	直通单座铸造球阀型 Through single seat casting ball valve	
公称直径(mm) Nominal diameter	40-200mm	
公称压力(MPa) Nominal pressure	ANSI 125、150、300、600 JIS 10、16、20、30、40k PN1.6、4.0、6.4MPa	
材料 material	Ht200 ZG25 ZG1Cr18Ni9 ZG0Cr17Ni12Mo2 1.25Cr0.5Mo 5.0Cr0.5Mo SCPH21 SCPH61 TI	
连接型式 Connection type	法兰式 flange	FF、RF、RJ、LG
	标准 standard	按ANSI B16.5; JIS B2201 JB/T79.1 PN1.6MPa, JB/T79.2 凹凸面
	焊接式 welded	对接焊SW(40-50mm) 对接焊BW(65-200mm) Scarf welding SW(40-50mm) Butt welding BW(65-200mm)
上阀盖 On valve cover	常温型(P) Temperature type	-17~+230°C
	伸长 I 型(E1) Elongation I type	-45~+17°C +230~+566°C
	伸长 II 型(E2) Elongation II type	整体式(E2 I): -100~-45°C 焊接式(E2W): -196~-100°C monolithic(E2 I): -100~-45°C welded(E2W): -196~-100°C
压盖型式 Gland type	螺栓压紧式 Bolt pressure type	
填料 packing	V型聚四氟乙烯填料, 含浸聚四氟乙烯石棉填料, 石棉编织填料。 V pte packing, including dipping teflon asbestos packing, asbestos braided packing.	

阀作用型式 Valve mode of action 附件 accessories 可调节范围 Adjustable range: 50:1

气—开式, 气—关式
Gas—open, gas—shut type

定位器、保位阀、手轮机构、气动两位变送器
Locator, protect a valve, hand wheel mechanism, pneumatic valve position transmitter, etc

执行机构 Actuator

型式 Type	Ha多弹簧式薄膜执行机构 Ha more spring type diaphragm actuator
膜片材料 Diaphragm material	乙丙橡胶夹尼龙 Ethylene propylene rubber clamp nylon
弹簧范围 Spring range	0.02-0.10, 0.08-0.24MPa
供气压力 Gas supply pressure	0.14, 0.16, 0.28, 4.0MPa
气源接头 Air joint	Rc 1/4
环境温度 Environment temperature	-30~+70°C
备注 note	该阀也可配用VAS和VP执行机构 This valve can also be with VAS and VP actuator

阀内组件 Valve components within

阀芯型式 Valve core type	单座套筒式柱塞阀芯 Single seat cover drum plunger valve core
流量特性 Flow characteristic	等百分比(%)和线性(L)(金属阀座) Equal percentage (%) and linear (L) (metal seat)
套筒形式 Sleeve forms	分离式套筒 separate sleeve
材料 material	-17-4PH, 0Cr17Ni12Mo2 司太素堆焊 Company too tal overlaying welding

性能 performance

泄漏量 leakage	符合标准ANSI B16.104 II级, 小于额定的Cv的0.5% Accord with a standard ANSI B16.104 II level, less than 0.5% of the rated Cv
回差 Return difference	3%(不带定位器); 1%(带定位器) 3% (without locator); 1% (with locator)
线性 linear	±5%(不带定位器); ±1%(带定位器) ±5% (without locator); ±1% (with locator)
备注 note	采用标准的V型四氟乙烯填料 The standard V tetrafluoroethylene packing

CV3000系列HSC笼式单座调节阀 CV3000 series HSC cage single seat valve



Cv值和行程 Cv value and stroke

公称直径(mm) Nominal diameter	40				50				65				80				100				150				200			
阀座直径(mm) Seat diameter	10	15	25	15	25	32	25	32	40	32	40	50	40	50	65	65	80	100	80	100	125							
额定Cv值 Rated Cv value	4.0	6.3	11	6.3	11	17	11	17	24	17	24	44	24	44	68	68	99	175	99	175	275							
额定行程(mm) Rated stroke	25								38								50				75							

Cv配HA执行机构 Cv with HA actuator

公称直径(mm) Nominal diameter	执行机构 actuator	H				C	φB	E
		P	E1	E2 I	E2W			
40	HA2D, R	500	665	750	1020	281	267	70
	HA3D, R	590	760	875	1140	363	350	
50	HA2D, R	500	670	785	1025	281	267	80
	HA3D, R	595	765	875	1140	363	350	
65	HA2D, R	575	745/755	880	1130	281	267	88
	HA3D, R	630	800/810	930	1180	363	350	
	HA4D, R	865	1035/1045	1165	1495	520	470	
	HA2D, R	580	755/765	900	1135	281	267	
80	HA2D, R	635	810/820	955	1190	363	350	98
	HA3D, R	635	810/820	955	1190	363	350	
	HA4D, R	870	1045/1055	1190	1505	520	470	
	HA2D, R	610	810/870	915	1150	281	267	
100	HA3D, R	660	860/870	1020	1205	363	350	113
	HA4D, R	890	1100/1110	1255	1520	520	470	
	VA5D	1300	1515	1710	1940	-	620	
	VA5R	1420	1635	1820	2050	-	620	
	VA6R	1160	1375	1560	1790	-	445	
	VP5	940	1155	1340	1570	-	345	
	HA3D, R	785	1020/1045	1250	1385	363	350	
150	HA4D, R	955	1190/1215	1425	1570	520	470	170
	VA5D	1360	1620	1870	2000	-	620	
	VA5R	1480	1740	1980	2110	-	620	
	VA6R	1220	1480	1720	1850	-	445	
	VP5	1000	1260	1500	1630	-	345	
	VP6	1210	1470	1710	1840	-	445	
	VP7	1290	1550	1790	1920	-	545	
200	HA4D, R	1090	1350	1580	1710	520	470	220
	VA5D	1475	1740	2025	2155	-	620	
	VA5R	1585	1850	2145	2275	-	620	
	VP5	1165	1425	1665	1795	-	345	
	VP6	1375	1635	1875	2005	-	445	
	VP7	1455	1715	1955	2085	-	545	

备注: 1、P=常温型, E1=伸长 I 型, E2=伸长 II 型, E2 I=整体式, E2W=焊接式。
2、表上H栏尺寸是调节阀不带手轮机构的数值, 如果带顶装手轮机构, 那么要相应加上手轮机构的尺寸, 查HA执行机构的技术参数表编号NO.AN10-29-2。
3、伸长 I 型E1栏尺寸, 左边数字为JIS 10K和ANSI 125, 150的阀, 右边数字为JIS 16K和ANSI 300以上的阀。
Note: 1、P=cold type, E1=elongation I type, E2=elongation II type, E2 I=monolithic, E2W=welding type.
2、and table on H column size is regulating valve without the handwheel mechanism of numerical, if take top loading wheel mechanism, then to the corresponding plus the handwheel mechanism size, check HA actuator technology parameter table knitting NO.AN10-29-2.
3、elongation I type E1 column size, the left number for JIS 10 K and ANSI 125,150 valve, the right number for JIS 16K and ANSI more than 300 valve.



CV3000系列HPS高压单座调节阀 CV3000 series HPS high single seat valve

HPS高压单座调节阀是一种顶导向结构的调节阀，阀体流体通道呈S流线型，压降损失小，流量大，可调范围广。阀芯导向部分的导向面积大，抗振性好。调节阀配用多弹簧式薄膜执行机构，结构紧凑，输出力大。产品符合GB/T4213-1992。

HPS high single seat valve is a top guide structure of the valve, the valve body fluid channel is S streamline, pressure drop loss small, large flow, adjustable range. Valve core guide part of the guide area is large, vibration resistance is good. Control valve with many spring type diaphragm actuator, compact structure, large output force. Products comply with GB/T4213-1992.

技术参数和性能 Technical parameters and performance

阀体 Body

型式 Type	直通单座铸造球阀 Through single seat casting ball valve
公称直径(mm) Nominal diameter	25-80mm
公称压力(MPa) Nominal pressure	ANSI 900/1500, 2500 JIS 63K
材料 material	ZG25 ZG1Cr18Ni9 ZG0Cr17Ni12Mo2 1.25Cr0.5Mo 2.2Cr1.0Mo 5.0Cr0.5Mo SCPH21 SCPH61 TI
连接型式 Connection type	法兰式 flange 标准 standard 按ANSI B16.5; JIS B2201 焊接式 welded 对接焊SW(25-80mm) 对接焊BW(80mm) Scarf welding SW(25-80mm) Butt welding BW(80mm)
上阀盖 On valve cover	常温型(P) Temperature type 伸长 I型(E1) Elongation I type -5~+230℃ +230~+566℃
备注 note	工作温度不准超过各种材料允许范围 Working temperature no more than all kinds of materials allow range
压盖型式 Gland type	螺栓压紧式 Bolt pressure type
填料 packing	石棉编织填料 asbestos braided packing.

阀作用型式 Valve mode of action 附件 accessories 可调范围 Adjustable range: 50:1
气—开式, 气—关式 Gas—open, gas—shut type 定位器, 保位阀, 手轮机构, 气动限位变送器
Locator, protect a valve, hand wheel mechanism, pneumatic valve position transmitter, etc

执行机构 Actuator

型式 Type	Ha多弹簧式薄膜执行机构 Ha more spring type diaphragm actuator
膜片材料 Diaphragm material	乙丙橡胶夹尼龙 Ethylene propylene rubber clamp nylon
弹簧范围 Spring range	0.04~0.20, 0.18~0.24MPa
供气压力 Gas supply pressure	0.25, 0.30, 0.35, 0.40MPa, 0.26~0.40MPa
气源接头 Air joint	Rc 1/4
环境温度 Environment temperature	-30~+70℃
备注 note	该阀也可配用VA和VP执行机构 This valve can also be with VAS and VP actuator

阀内组件 Valve components within

阀芯型式 Valve core type	单座柱塞阀芯 Single seat plunger valve core
流量特性 Flow characteristic	等百分比(%)和线性(L)(金属座) Equal percentage (%) and linear (L) (metal seat)
材料 material	1Cr18Ni9Ti, 0Cr17Ni12Mo2, Ti8Cr17 不锈钢或钛合金 Stainless steel or titanium alloy
性能 performance	泄漏量 符合标准ANSI B16.104 II级, 小于额定Cv的0.5% leakage Accord with a standard ANSI B16.104 II level, less than 0.5% of the rated Cv
回差 Return difference	1% (带定位器) 1% (with locator)
线性 linear	±1% (带定位器) ±1% (with locator)

Cv值和行程 Cv value and stroke

公称直径(mm) Nominal diameter	25																40				50				80							
阀座直径(mm) Seat diameter	25																32	40	32	40	50	50	65	80								
额定Cv值 Rated Cv value	ANSI 63K ANSI 900/1500		0.25	0.4	0.63	1.0	1.6	2.5	4.0	6.3	12	12	17	25	17	25	47	47	75	110	ANSI 2500											
额定行程(mm) Rated stroke	14.3																25				38											

CV3000系列HPS高压单座调节阀 CV3000 series HPS high single seat valve

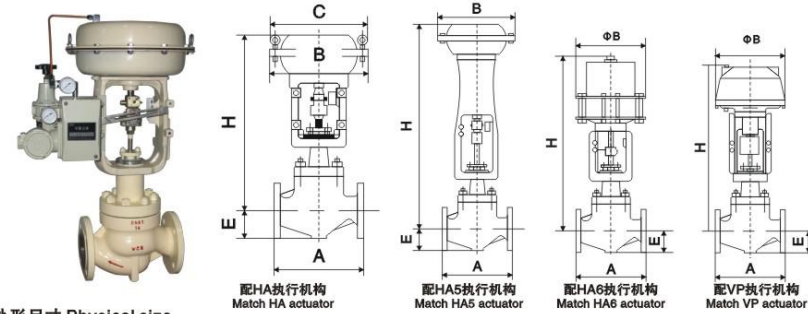

外形尺寸 Physical size

公称直径(mm) Nominal diameter	执行机构 actuator	H						E			C	φB
		ANSI 900 JIS 63K		ANSI 1500		ANSI 2500		ANSI 900	ANSI 1500	ANSI 2500		
		P	E1	P	E1	P	E1					
25	HA3D, R	710	840	710	840	740	860	90	90	95	363	350
	HA4D, R	870	1000	870	1000	900	1020				520	470
	VA6R	1115	1245	1115	1245	1145	1265				-	445
	VP5	895	1025	895	1025	1925	1045				-	345
	VP6	1140	1280	1140	1280	1185	1330				-	445
40	HA3D, R	735	875	735	875	780	925	100	105	120	363	350
	HA4D, R	890	1030	890	1030	935	1080				520	470
	VA5D	1280	1420	1280	1420	1325	1470				-	620
	VA5R	1390	1530	1390	1530	1435	1580				-	620
	VA6R	1140	1280	1140	1280	1185	1350				-	445
	VP5	920	1060	920	1060	965	1110				-	345
	VP6	1140	1280	1140	1280	1185	1330				-	445
50	HA3D, R	765	925	765	925	800	960	110	120	130	363	350
	HA4D, R	925	1080	925	1080	960	1120				520	470
	VA5D	1315	1475	1315	1475	1350	1510				-	620
	VA5R	1425	1585	1425	1585	1460	1620				-	620
	VA6R	1175	1335	1175	1335	1210	1370				-	445
	VP5	955	1115	955	1115	990	1150				-	345
	VP6	1175	1135	1175	1135	1210	1370				-	445
80	VP7	1270	1420	1270	1420	1305	1465	-	545			
	HA3D, R	800	980	800	980	835	1005	140	150	165	363	350
	HA4D, R	960	1140	960	1140	995	1165				520	470
	VA5D	1345	1525	1345	1525	1380	1550				-	620
	VA5R	1455	1635	1455	1635	1490	1660				-	620
	VA6R	1205	1385	1205	1385	1240	1410				-	445
	VP5	985	1165	985	1165	1220	1190				-	345
VP6	1205	1385	1205	1385	1240	1410	-				445	
VP7	1295	1475	1295	1475	1330	1500	-	545				

备注: 1. P=常温型, E1=伸长 I型, E2=伸长 II型, E2 I=整体式, E2W=焊接式。
2. 表上H栏尺寸是调节阀不带手轮机构的数值, 如果带顶装手轮机构, 那么要相应加上手轮机构的尺寸, 查HA执行机构的技术参数表编号NO.AN10-29-2。
Note: 1. P = cold type, E1 = elongation I type, E2 = elongation II type, E2 I = monolithic, E2W = welding type.
2. and table on H column size is regulating valve without the handwheel mechanism of numerical, if take top loading wheel mechanism, then to the corresponding plus the handwheel mechanism size, check HA actuator technology parameter table knitting NO.AN10-29-2.

外形尺寸 Physical size

阀配用HA或VA执行机构(带定位器) Valve with HA or VA actuator (with locator)
气—关式阀 Gas—shut type valve

公称压力(MPa) Nominal pressure	执行机构 actuator	供气压力 (MPa) Gas supply pressure	弹簧范围 (MPa) Spring range	允许压差(MPa) Allow differential pressure							
				阀座直径(mm)或Cv值 Seat diameter (mm) or Cv value							
				Cv≤4.0	Cv≤6.3	Cv≤12	32	40	50	65	80
ANSI 900 1500 JIS 63K	HA3D	0.28	0.04-0.20	16.3 15.2	16.1 14.9	10.2 9.2	5 4.2	3.2 2.7	1.8 1.4	1 0.70	0.70 0.40
		0.30	0.04-0.20	20.7 19.6	20.5 19.2	13 12	6.4 5.7	4.2 3.6	2.4 1.9	1.4 1	0.90 0.60
		0.35	0.04-0.20	26.4	26.4	20 19	10 9.2	6.6 6	3.8 3.4	2.3 1.9	1.6 1.3
		0.40	0.04-0.20	-	-	26.4 26	13.5 12.8	9.1 8.5	5.3 4.8	3.2 2.8	2.2 1.9
	HA4D	0.28	0.04-0.20	-	-	18.3 17.3	9.1 8.4	6.1 5.5	3.5 3	2.1 1.7	1.4 1.1
		0.30	0.04-0.20	-	-	23.1 22.1	11.6 10.9	7.7 7.1	4.5 4	2.7 2.3	1.9 1.6
		0.35	0.04-0.20	-	-	26.4	17.7 17	11.9 11.3	6.5 6	4.2 3.9	3 2.7
		0.40	0.04-0.20	-	-	23.9 23.2	16.1 15.5	9.5 9	5.8 5.4	4.1 3.8	
	HA5D	0.26	0.02-0.10	-	-	26.3 25.5	17.7 17.1	10.4 10	6.3 6	4.5 4.2	
		0.28	0.02-0.10	-	-	26.4	20 19.4	11.8 11.4	7.2 6.8	5.1 4.8	
	ANSI 2500	HA3D	0.28	0.04-0.20	16.3 15.2	16.1 14.9	10.2 9.2	5 4.2	2.5 2	1.8 1.4	1 0.7
			0.30	0.04-0.20	20.7 19.6	20.5 19.2	13 12	6.4 5.7	3.3 2.8	2.4 1.9	1.4 1
0.35			0.04-0.20	31.6 30.5	31.4 30.1	20 19	10 9.2	5.2 4.7	3.8 3.4	2.3 1.9	
0.40			0.04-0.20	42.5 41.4	42.3 41	27 26	13.5 12.8	7.2 6.7	5.3 4.8	3.2 2.8	
HA4D		0.28	0.01-0.20	-	-	18.3 17.3	9.1 8.4	4.8 4.3	3.5 3	2.1 1.7	
		0.30	0.04-0.20	-	-	23.1 22.1	11.6 10.9	6.1 5.6	4.5 4	2.7 2.3	
		0.35	0.04-0.20	-	-	35.1 34.1	17.7 17	9.5 8.9	7 6.5	4.2 3.9	
		0.40	0.04-0.20	-	-	44	23.9 23.2	12.8 12.3	9.5 9	5.8 5.4	
VA5D		0.26	0.02-0.10	-	-	26.3 25.5	14.1 13.6	10.4 10	6.3 6		
		0.28	0.02-0.10	-	-	29.6 28.9	15.9 15.4	11.8 11.4	7.2 6.8		

备注: 1、深色框内数字表示阀配用标准规格执行机构。

2、最大允许压差不超过ANSI B16.34或JIS B 2201标准规定的最大值。

3、进口压力P1不准超过阀关闭时的最大允许压差。

4、最大允许压差随阀座泄漏量不同而变化，同一格内上方压差表示阀座泄漏量≤0.01%时，下方压差表示阀座泄漏量≤0.001%时。

Note: 1、dark frame in digital representation valve with standard specifications actuator.

2、the maximum allowable pressure difference no more than ANSI B16.34 or JIS B 2201 standard maximum.

3、Inlet pressure P1 no more than valve closing of the maximum allowable pressure difference.

4、maximum allowable pressure difference with seat leakage and different changes, the same case above in differential pressure said seat leakage aculties ≤ 0.01%, below pressure differential said seat leakage ≤ 0.001%

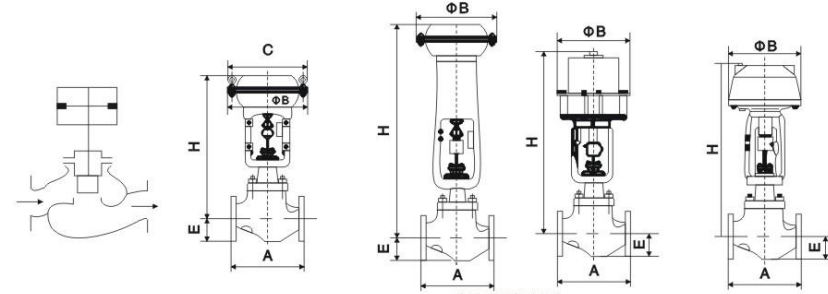

法兰距及外形尺寸
Flange distance and external dimensions

阀配用LVP执行机构(带定位器) Valve with LVP actuator (with locator)

公称压力(MPa) Nominal pressure	执行机构 actuator	公称直径(mm) Nominal diameter	供气压力 Gas supply pressure		
			3	4	5
ANSI900、1500 JIS63K	LVP5	150	198	264	264
			242	264	264
198			264	330	
281			289	440	
ANSI 900、1500 JIS63K	LVP6	200	191	255	264
			264	264	264
192			255	319	
440			440	440	

注: 1.如果执行机构带有辅助气源, 应选用二者中较小一个供气压力作为计算允许压差的。

2.最大允许压差不超过ANSI B16.34标准规定的最大值。

3.进口压力P1不准超过阀关闭时的最大允许压差。

4.同一格内上方数字表示阀常开允许压差, 数字表示阀全关允许压差。

5.全关时的允许压差的条件是 $\Delta P = P_1$ ($P_2 = 0$), 全关时的压差随出口压力 P_2 不同稍有变化。

Note: 1. If actuators with auxiliary air, should choose the smaller both a gas supply pressure as computing allows pressure difference.

2. Maximum allowable pressure difference no more than ANSI B16.34 standard maximum.

3. Inlet pressure P1 no more than valve closing of the maximum allowable pressure difference.

4. In the same case above digital representation valve normally open allows pressure difference, digital said valve seated allows pressure difference.

5. List the permission of the closed differential pressure condition is $\Delta P = P_1$ ($P_2 = 0$), when all of the differential pressure with a slight change of different outlet pressure P2.

法兰距 Face to Face dimension

公称直径 (mm) Nominal diameter	A							
	JIS63K	ANSI 900		ANSI 1500		ANSI 2500		
	RF	RF(SW,BW)	RJ	RF(SW,BW)	RJ	RF(SW,BW)	RJ	
40	323	333	333	333	333	358	361	
50	354	375	378	375	378	400	403	
80	431	440	443	480	463	498	504	
100	496	510	513	530	533	575	585	
150	699	715	718	770	776	820	833	
200	895	915	918	972	982	1020	1036	



CV3000系列TCB笼式双座调节阀 CV3000 series TCB cage two-seater regulator

TCB笼式调节阀是一种改进型压力平衡式的调节阀,该阀套筒上装有高性能的密封环,有效的提高了泄漏等级,阀体流体通道呈S流线性,还设有一个改善套筒周围流体平稳流动的导流翼,优点是压降损失小,流量大,可调范围宽,流量特性曲线精度高,动态稳定性好,噪音低,空化腐蚀小。

调节阀配用多弹簧式薄膜执行机构,结构紧凑,输出力大。

TCB cage control valve is a kind of advanced pressure balance type valve, the valve sleeve with high performance sealing ring, effective improve the leakage level, body fluid channel is S streamline. There is also improve sleeve surrounding fluid smooth flow of the fin, the advantage is pressure drop loss small, large flow, adjustable scope, the flow characteristic of high accuracy, good dynamic stability, low noise, Cavitation corrosion small.

Control valve with many spring type diaphragm actuator, compact structure, large output force.

技术参数和性能 Technical parameters and performance

阀体 Body

型式 Type	直通单座铸造球阀 Through single seat casting ball valve	
公称直径(mm) Nominal diameter	40, 50, 65, 80, 100mm	
公称压力(MPa) Nominal pressure	ANSI 125, 150, 300, 600 JIS 10, 16, 20, 30, 40K PN 1.6, 4.0, 6.4MPa	
材料 material	HT2000 ZG25 ZGICr18Ni9 ZG0Cr17Ni12Mo2 1.25Cr0.5Mo 5.0Cr0.5Mo SCPH21 SCPH61	
连接型式 Connection type	法兰式 flange	FF, RF, RJ, LG
	标准 standard	标准按JIS ANSI B16.5, JB/T79.1 PNI.6MPa, J B/T79.2凹凸面
上阀盖 On valve cover	常温型(P) Temperature type	-17~+230℃
	高温型 Type high temperature	+230~+300℃
备注 note	工作温度不准超过各种材料允许范围 Working temperature no more than all kinds of materials allow range	
压盖型式 Gland type	螺栓压紧式 Bolt pressure type	
填料 packing	V型聚四氟乙烯填料, 含浸聚四氟乙烯石棉填料, 石棉编织填料。 V ptfе packing, including dipping teflon asbestos packing, asbestos braided packing.	

阀作用型式 Valve mode of action 附件 accessories 可调范围 Adjustable range: 50:1
气—开式, 气—关式 Gas—open, gas—shut type 定位器、保位阀、手轮机构、气动阀位变送器
Locator, protect a valve, hand wheel mechanism, pneumatic valve position transmitter, etc

执行机构 Actuator

型式 Type	Ha多弹簧式薄膜执行机构 Ha more spring type diaphragm actuator
膜片材料 Diaphragm material	乙丙橡胶夹尼龙 Ethylene propylene rubber clamp nylon
弹簧范围 Spring range	0.02~0.10, 0.08~0.24MPa
供气压力 Gas supply pressure	0.14, 0.16, 0.28, 0.40MPa
气源接头 Air joint	Rc 1/4
环境温度 Environment temperature	-30~+70℃

性能 performance

泄漏量 leakage	符合标准ANSI B16.1041B级, 小于额定Cv的0.01% Accord with a standard ANSI B16.1041Blevel, less than 0.01% of the rated Cv
回差 Return difference	1%(带定位器) 1% (with locator)
线性 linear	±1%(带定位器) ±1% (with locator)
备注 note	采用标准的V型聚四氟乙烯填料 The standard V ptfе packing

阀内组件 Valve components within

阀芯型式 Valve core type	压力平衡式阀芯 Pressure balance type valve core	
流量特性 Flow characteristic	高精度流量特性 High precision flow characteristic	金属阀座等百分比特性(%)和线性(L) Metal seat equal percentage (%) and linear (L)
	高容量流量特性 High volume flow characteristic	金属阀座等百分比特性(%)和线性(L) Metal seat equal percentage (%) and linear (L)
工作范围 Scope of work	司太莱堆焊的工作温度和压差 Company too lai overlaying welding work temperature and pressure difference	
材料 material	1Cr18Ni9Ti, 0Cr17Ni12Mo2, Ti8Cr17, 不锈钢堆焊司太莱合金 Stainless steel surfacing company too lai alloy	

CV3000系列TCB笼式双座调节阀 CV3000 series TCB cage two-seater regulator



Cv值和行程 Cv value and stroke

公称直径(mm) Nominal diameter		40		50		65		80		100								
阀座直径(mm) Seat diameter		25	32	40	32	40	50	40	50	65	50	65	80	65	80	100		
额定Cv Rated Cv	高精度套筒 High precision sleeve	等百分比特性 线性特性 Equal percentage characteristic Linear characteristic		11	17	24	17	24	44	24	44	68	44	68	99	68	99	175
	高容量套筒 High capacity sleeve	等百分比特性 线性特性 Equal percentage characteristic Linear characteristic		36		60		100		140		220						
额定行程(mm) Rated stroke		25						38										

允许压差 Allow differential pressure

气—关式阀 Gas a close type valve

单位: MPa

执行机构 actuator	供气压力 Gas supply pressure	弹簧范围 Spring range	允许压差 Allow differential pressure				
			公称直径(mm) Nominal diameter				
			40	50	65	80	100
HA2D	0.16	0.02~0.10	4.0 4.92	3.8	3.29	2.74	2.08
	0.40	0.08~0.24	4.0 10.0	4.0 10.0	4.0 9.87	4.0 8.23	4.0 6.28
HA3D	0.16	0.02~0.10	4.0 8.7	4.0 6.7	4.0 5.5	4.0 4.87	4.0 3.7
	0.40	0.08~0.24	4.0 10.0	4.0 10.0	4.0 10.0	4.0 10.0	4.0 10.0
HA4D	0.16	0.02~0.10			4.0 10.0	4.0 8.39	4.0 6.36
	0.40	0.08~0.24			4.0 10.0	4.0 10.0	4.0 10.0

气—开式阀 Gas a open valve

单位: MPa

执行机构 actuator	供气压力 Gas supply pressure	弹簧范围 Spring range	允许压差 Allow differential pressure				
			公称直径(mm) Nominal diameter				
			40	50	65	80	100
HA2R	0.28	0.08~0.24	4.0	4.0	4.0		2.93
			6.81	5.39	4.6	3.84	
HA3R	0.28	0.08~0.24	4.0	4.0	4.0	4.0	4.0
			10.0	9.57	8.17	6.8	5.18
HA4R	0.28	0.08~0.24			4.0	4.0	4.0
					10.0	10.0	8.97

- 备注: 1. 深色框内数字表示阀配用标准规格执行机构。
2. 最大允许压差不准超过ANSI B16.34或JIS B2201规定的最大值。
3. 同一格内上方数字为阀全开允许压差, 下方数字为阀全关允许压差。
4. 表中压差均为带定位器时的压差。
Note: 1. dark frame in digital representation valve with standard specifications actuator.
2. the maximum allowable pressure difference no more than ANSI B16.34 or JIS B2201 prescribed maximum.
3. the same cell number above for valve fully open allows pressure difference, below digital for valve seated allow difference.
4. table medium pressure difference are belt positioner of differential pressure.

CV3000系列TCB笼式双座调节阀 CV3000 series TCB cage two-seater regulator

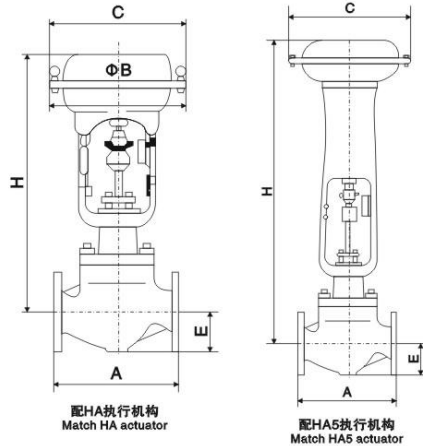

外形尺寸 Physical size

单位 unit: mm

公称直径(mm) Nominal diameter	执行机构 actuator	H	C	ΦB	E
40	HA2D,R	500	281	267	70
	HA3D,R	590	363	350	
50	HA2D,R	500	281	267	80
	HA3D,R	595	363	350	
65	HA2D,R	575	281	267	90
	HA3D,R	630	363	350	
	HA4D,R	865	520	470	
80	HA2D,R	580	281	267	100
	HA3D,R	635	363	350	
	HA3D,R	870	520	470	
100	HA2D,R	610	281	267	115
	HA3D,R	660	363	350	
	HA4D,R	890	520	470	
	VA5R	1420	-	620	
	VA6R	1160	-	445	

备注: 表上H尺寸是调节阀不带手轮机构时的数值, 若带顶装手轮机构, 那么要相应加上手轮机构的尺寸, 查HA执行机构的技术参数编号为No. AN10-29-2
Note: list H size is regulating valve without the handwheel mechanism of numerical. If take top loading wheel mechanism, then to the corresponding plus the handwheel mechanism size, check HA actuator Technical parameter table Numbers for No. AN10-29-2

CV3000系列HPC高压笼式调节阀 CV3000 series HPC high pressure cage control valve

HPC高压笼式调节阀是一种压力平衡式调节阀, 筒体流体通道呈S流线型, 压降损失小, 流量大, 可调节范围广, 调节阀配用多弹簧式薄膜执行机构, 结构紧凑, 输出力大。该阀广泛应用于要求动态稳定性好、噪音低、空化腐蚀小的高压降场合。
产品符合GB/T4213-1992。

HPC high pressure cage control valve is a kind of pressure balance type valve, body fluid channel is S streamline, pressure drop loss small, large flow, adjustable range, control valve with many spring type diaphragm actuator, compact structure, large output force. The valve is widely used in the dynamic requirements good stability, low noise, cavitation corrosion small high pressure drop occasion.

Products comply with GB/T4213-1992.

技术参数和性能 Technical parameters and performance

阀体 Body

型式 Type	直通笼式铸造球阀 Through cage casting ball valve
公称直径(mm) Nominal diameter	40-200mm
公称压力(MPa) Nominal pressure	ANSI 900, 1500, 2500 JIS 63K
材料 material	ZG25 ZG1Cr18Ni9 ZG0Cr17Ni12Mo2 1.25Cr0.5Mo 2.2Cr1.0Mo 5.0Cr0.5Mo SCPH21 SCPH61 TI
连接型式 Connection type	法兰式 flange 标准 standard 焊接式 welded
	RF, RJ 按ANSI B16.5; JIS B2201
	对接焊SW40-80mm 对接焊BW(80-200mm) Scarf welding SW40-80mm Butt welding BW(80-200mm)
上阀盖 On valve cover	常温型(P) Temperature type 伸长率(E1) Elongation I type
	-5~+230℃ +230~+566℃
备注 note	工作温度不准超过各种材料允许范围 Working temperature no more than all kinds of materials allow range
压紧型式 Gland type	螺栓压紧式 Bolt pressure type
填料 packing	石棉编织填料 asbestos braided packing.

阀作用型式 Valve mode of action

气—开式, 气—关式
Gas - open, gas - shut type

附件 accessories

定位器、保位阀、手轮机构、气动两位变送器
Locator, protect a valve, hand wheel mechanism, pneumatic valve position transmitter, etc

可调节范围 Adjustable range: 50:1

执行机构 Actuator

型式 Type	Ha多弹簧式薄膜执行机构 Ha more spring type diaphragm actuator
膜片材料 Diaphragm material	乙丙橡胶夹尼龙 Ethylene propylene rubber clamp nylon
弹簧范围 Spring range	0.04-0.20, 0.18-0.24MPa
供气压力 Gas supply pressure	0.25, 0.30, 0.35, 0.40MPa
气源接头 Air joint	Rc 1/4
环境温度 Environment temperature	-30~+70℃
备注 note	该阀也可配用VA5或VA6和VP执行机构 This valve can also be with VA5 or VA6 and VP actuator

阀内组件 Valve components within

阀芯型式 Valve core type	金属阀座的压力平衡式结构 Metal seat pressure balanced structure
流量特性 Flow characteristic	等百分比(%)和线性(L) Equal percentage (%) and linear (L)
材料 material	1Cr18Ni9Ti, 0Cr17Ni12Mo2, Ti8Cr17 不锈钢堆焊司太素合金 Stainless steel surfacing company too lal alloy
性能 performance	
泄漏量 leakage	符合标准ANSI B16.104 II级, 小于额定Cv的0.01% Accord with a standard ANSI B16.104 II level, less than 0.01% of the rated Cv
回差 Return difference	1% (带定位器) 1% (with locator)
线性 linear	±1% (带定位器) ±1% (with locator)

Cv值和行程 Cv value and stroke

公称直径(mm) Nominal diameter	40		50		80		100		150		200									
	25	32	40	32	40	50	50	65	80	65	80	100	100	125	150	125	150	200		
额定Cv值 Rated Cv value	JIS 63K ANSI 900 1500		12	17	25	17	25	52	52	78	110	78	110	180	180	270	375	270	375	650
	ANSI 2500		-	12	17	12	17	31	31	52	78	52	78	125	125	180	270	180	270	470
	JIS 63K ANSI 900 1500		12	20	30	20	30	62	62	90	135	90	135	210	210	330	485	330	485	700
	ANSI 2500		-	12	20	12	20	43	43	62	90	62	90	150	150	210	330	210	330	520
额定行程(mm) Rated stroke			25				38				50				75					

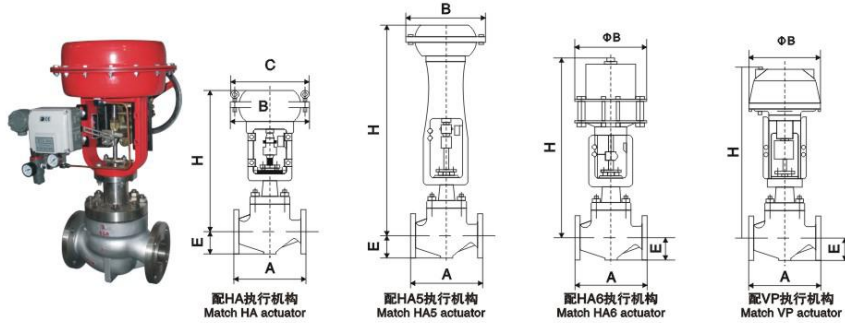

外形尺寸 Physical size

公称直径(mm) Nominal diameter	执行机构 actuator	H						E			C	ΦB
		ANSI 900 JIS 63K		ANSI 1500		ANSI 2500		ANSI 900	ANSI 1500	ANSI 2500		
		P	E1	P	E1	P	E1					
40	HA3	735	875	735	875	780	725	100	105	115	363	350
	HA4	890	1030	890	1030	935	1080				520	470
50	HA3	765	925	765	925	300	960	110	120	130	363	350
	HA4	725	1085	925	1085	960	1120				520	470
80	HA3	800	980	800	980	835	1005	140	150	165	363	350
	HA4	960	1140	960	1140	995	1165				520	470
100	HA3	835	1015	835	1015	880	1050	160	170	195	363	350
	HA4	995	1175	995	1175	1040	1210				520	470
	HA5D	1380	1560	1380	1560	1425	1595				-	620
	VA5R	1490	1670	1490	1670	1535	1705				-	620
150	VA6R	1229	1409	1229	1409	1274	1444	210	225	260	-	445
	HA3	895	1075	895	1075	935	1110				363	350
	HA4	1055	1235	1055	1235	1095	1270				520	470
	VA5D	1440	1620	1440	1620	1480	1655				-	620
	VA5R	1550	1730	1550	1730	1590	1765				-	620
	VA6R	1300	1480	1300	1480	1340	1515				-	445
200	VP5	1080	1260	1080	1260	1120	1295	280	290	330	-	345
	HA4	1155	1395	1150	1395	1185	1370				520	470
	VA5D	1545	1785	1545	1785	1575	1760				-	620
	VA5R	1655	1895	1655	1895	1685	1870				-	620
	VP6	1395	1635	1395	1635	1425	1610	-	445			

备注: 1. P=常温型, E1=伸长 I 型, E2=伸长 II 型, E2 I =整体式, E2W=焊接式。
2. 表上H栏尺寸是调节阀不带手轮机构的数值, 如果带顶装手轮机构, 那么要相应加上手轮机构的尺寸, 查HA执行机构的技术参数表编号NO.AN10-29-2。
Note: 1.P = cold type, E1 = elongation I type, E2 = elongation II type, E2 I = monolithic, E2W = welding type.
2. and table on H column size is regulating valve without the handwheel mechanism of numerical, if take top loading wheel mechanism, then to the corresponding plus the handwheel mechanism size, check HA actuator technology parameter table Numbers NO. AN10-29-2.

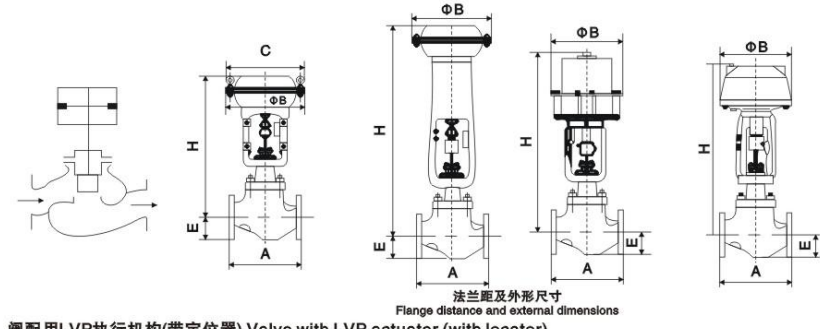

阀配用LVP执行机构(带定位器) Valve with LVP actuator (with locator)

公称压力(MPa) Nominal pressure	执行机构 actuator	公称直径(mm) Nominal diameter	供气压力 Gas supply pressure		
			3	4	5
ANSI900、1500 JIS63K	LVP5	150	198	264	264
			242	264	264
ANSI 2500	LVP5	150	198	264	330
			281	289	440
ANSI 900、1500 JIS63K	LVP6	200	191	255	264
			264	264	264
ANSI 2500	LVP6	200	192	255	319
			440	440	440

注: 1. 如果执行机构带有辅助气源, 应选用二者中较小一个供气压力作为计算允许压差的。
2. 最大允许压差不超过ANSI B16.34标准规定的最大值。
3. 进口压力P1不超过阀门关闭时的最大允许压差。
4. 同一格内上方数字表示调节阀开允许压差, 数字表示阀门全关允许压差。
5. 表上关闭时的允许压差的条件是 $\Delta P = P1 (P2 = 0)$, 全关闭的压差随出口压力P2不同稍有变化。
Note: 1. If actuators with auxiliary air, should choose the smaller both a gas supply pressure as computing allows pressure differential.
2. Maximum allowable pressure difference no more than ANSI B16.34 standard maximum.
3. Inlet pressure P1 no more than valve closing of the maximum allowable pressure difference.
4. In the same case above digital representation valve normally open allows pressure difference, digital said valve seated allows pressure difference.
5. List the permission of the closed differential pressure condition is $\Delta P = P1 (P2 = 0)$, when all of the differential pressure with a slight change of different outlet pressure P2.

法兰距 Face to Face dimension

公称直径 (mm) Nominal diameter	A						
	JIS63K	ANSI 900		ANSI 1500		ANSI 2500	
		RF	RF(SW,BW)	RJ	RF(SW,BW)	RJ	RF(SW,BW)
40	323	333	333	333	333	358	361
50	354	375	378	375	378	400	403
80	431	440	443	480	463	498	504
100	496	510	513	530	533	575	585
150	699	715	718	770	776	820	833
200	895	915	918	972	982	1020	1036

ZHAN系列精小型气动薄膜直通双座调节阀,由ZHA型气动薄膜多弹簧执行机构和直通双座阀组成。两部分与ZMAN系列气动薄膜直通双座调节阀的一样,具有流通能力较大,不平衡力小,更换作用方式方便等优点,但由于采用了ZHA型气动执行机构,体积小、重量轻,因此可广泛用于石化、纺织等行业中泄漏要求不严格而安装空间紧凑的自控系统。

ZHAN series fine small pneumatic film through two-seater regulator, the ZHA type pneumatic film much spring actuator and through two-seater valve composition. Valve part and ZMAN series pneumatic film through two-seater regulator, has the flow capacity is larger, unbalanced force is small, the changing mode of action is convenient wait for an advantage, but as a result of the ZHA type pneumatic actuators, small volume, light weight, so can be widely used in petrochemical, textile, and other industries leakage requirement not strict and installation space compact automatic control system.

产品型号 Product model

产品型号 Product model	ZHAN-16型	ZHAN-40型	ZHAN-64型	ZHAN-64G型
-----------------------	----------	----------	----------	-----------

主要技术参数 Main technical parameters

公称通径(mm) Nominal diameter	25	32	40	50	65	80	100	125	150	200
阀座直径(mm) Seat diameter	26,24	32,30	40,38	50,48	66,64	80,78	100,98	125,123	150,148	200,197
额定流量系数Kv Rated flow coefficient	10	16	25	40	63	100	160	250	400	630
流量特性 Characteristics	直线, 等百分比 Straight line, equal percentage									
公称压力(MPa) Nominal pressure	1.6, 4.0, 6.4									
连接型式 Connection type	法兰连接: PN1.6按JB78-59标准, PN4.0、6.4按JB79-59标准 Flange even by: PN1.6 according to JB78-59 standard, PN4.0, 6.4 regulation according to JB79-59 standard									
配用执行机构型号 With actuator type	ZHA-22	ZHA-23	ZHA-34	ZHA-45						
有效面积Fe(cm ²) Effective area	350			560			900			
行程L(mm) stroke	16	25	40	60						
作用方式 Mode of action	气关式; 气开式 Gas close type; Gas open type									
弹簧压力范围(KPa) Spring pressure range	标准20-100, 可选用40-200、20-60、60-100 standard20-100, Can choose40-200, 20-60, 60-100									
供气压力(Mpa) Gas supply pressure	标准0.14; 可选用0.25,0.4 standard0.14; Can choose0.25,0.4									
气源接头 Air joint	M16 x 1.5									
固有可调比R Inherent Rangesability	30:1									

主要技术性能指标 The main technical performance index

项目 project	不带阀门定位器 Don't take valve positioner	带阀门定位器 Take the valve positioner
基本误差% Basic main difference	≤ ±5	≤ ±1
回差% Return difference	≤3	≤1
死区% Dead zone	≤3	≤0.4
泄漏量 leakage	0.01% × 阀额定容量 0.01% × Valve rated capacity	
额定流量系数误差% Rated flow coefficient of the error	≤ ±10	

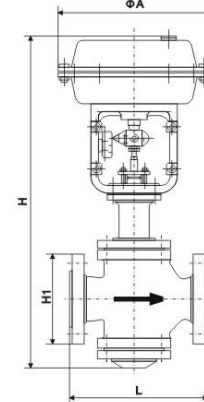

阀体材料和适用温度范围 The valve body material and suitable temperature range

阀体材料 Body material	材料牌号 Material brand	公称压力(MPa) Body ratings	适用温度范围(°C) Suitable temperature range	
			常温型 Cold type	热片型 Hot strip type
铸铁 Cast iron	HT200	1.6	-20-200	-
铸钢 Cast steel	ZG230-450	4.0,6.4	45-250	-40-450
铸不锈钢 Cast stainless steel	ZG1Cr18Ni9Ti ZG0Cr18Ni12Mo2Ti	4.0,6.4	-40-250	-60-450

允许压差 Allow differential pressure

标准组配的精小型气动薄膜双座调节阀建议工作压力差不超过1MPa,当压差超过允许值时,可通过调整弹簧预紧力,配用阀门定位器或选用其它执行机构来克服不平衡力。

Standard matched fine small pneumatic film two-seater regulator suggest operating differential pressure does not exceed 1MPa,when the pressure difference exceeds permissible value, can through adjusting spring pre-tightening force, with valve positioner or choose other actuators to overcome unbalanced force.

外形尺寸 Physical size

单位 unit: mm

公称通径(mm) Nominal diameter	ΦA	L			H		H1
		PN1.6	PN4.0	PN6.4	常温型 Cold type	热片型 Hot strip type	
25	285	184	190	200	453	604	104
32		200	210	210	456	607	107
40		220	230	235	503	654	126
50		250	255	265	508	659	131
65	360	275	285	295	649	800	175
80		300	310	320	650	810	190
100		350	355	370	671	822	202
125	470	410	425	440	855	1070	250
200		450	460	475	865	1080	260
250		550	560	570	907	1122	302

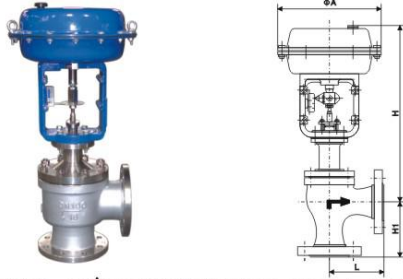

ZH^A_BS系列精小型气动薄膜角形调节阀，由ZH^A_B型气动薄膜多弹簧执行机构和角形阀组成。体积小，重量轻。阀芯采用顶端导向结构；阀体内流路简单、无死角；因此，可以避免介质的结晶、粘堵、堵塞等现象，有一定的自清洗能力。本产品适用于调节高粘度，含有悬浮物的介质。

ZH^A_BS series of fine small pneumatic film Angle regulator, by ZH^A_B pneumatic film much spring actuator and Angle valve composition. Small volume, light weight. Valve core using the top guide structure. The body flow is simple, no dead Angle. Therefore, to avoid medium coking, bonding and plugging wait for a phenomenon, has certain self-cleaning capacity. This product is suitable for regulating high viscosity, contains suspended matter medium.

产品型号 Product model

产品型号 Product model	ZH ^A _B S-64型	ZH ^A _B S-64G型
-----------------------	------------------------------------	-------------------------------------

主要技术参数 Main technical parameters

公称通径(mm) Nominal diameter	20										25	32	40	50	65	80	100	125	150	200
阀座直径(mm) Seat diameter	10	12	15	20	26	32	40	50	66	80	100	125	150	200						
额定流量系数Kv Rated flow coefficient	1.6	2.5	4.0	6.3	10	16	25	40	63	100	160	250	400	630						
流量特性 Characteristics	直线，等百分比 Straight line, equal percentage																			
公称压力(MPa) Nominal pressure	6.4																			
连接型式 Connection type	法兰连接：PN6.4按JB78-59标准 Flange even by: PN6.4 according to JB78-59 standard																			
执行机构型号 With actuator type	ZH ^A _B -22					ZH ^A _B -23					ZH ^A _B -34					ZH ^A _B -45				
有效面积F ₀ (cm ²) Effective area	350					350					560					900				
行程L(mm) stroke	10					16					25					40				
作用方式 Mode of action	气关式；气开式 Gas close type; Gas open type																			
弹簧压力范围(KPa) Spring pressure range	标准20-100，可选用40-200、20-60、60-100、80-240 standard 20-100, Can choose 40-200, 20-60, 60-100, 80-240																			
供气压力(MPa) Gas supply pressure	标准0.14；可选用0.25, 0.4 standard 0.14; Can choose 0.25, 0.4																			
气源接头 Air joint	M16×1.5																			
固有可调比R Inherent Rangesibility	30:1																			

主要技术性能指标

The main technical performance index

项目 project	不带阀门定位器 Don't take valve positioner	带阀门定位器 Take the valve positioner
基本误差% Basic main difference	≤ ±5	≤ ±1
回差% Return difference	≤ 3	≤ 1
死区% Dead zone	≤ 3	≤ 0.4
泄漏量 leakage	0.01% × 阀额定容量 0.01% × Valve rated capacity	
额定流量系数误差% Rated flow coefficient of the error	Kv>6.3时 ≤ +10 Kv>6.3时 ≤ +15	

阀体材料和适用温度范围

The valve body material and suitable temperature range

阀体材料 Body material	材料牌号 Material brand	公称压力 (MPa) Nominal pressure	适用温度范围(°C) Suitable temperature range
铸钢 Cast steel	ZG230-450	6.4	-40 ~ 250 -40 ~ 450
铸不锈钢 Cast stainless steel	ZG1Cr18Ni9Ti ZG0Cr18Ni12Mo2Ti	6.4	-40 ~ 250 -60 ~ 450

允许压差 Allow differential pressure

单位 unit: MPa

作用方式 Mode of action	执行机构 型号 Actuator type	弹簧范围 (KPa) Spring range	气源压力 Mpa Air pressure	所需附件 附件名称 Accessories	公称通径(阀座直径)(mm) Nominal diameter (Seat diameter)															
					20				25	32	40	50	65	80	100	125	150	200		
					(10)	(12)	(15)	(20)												
气 关 式 Gas close	ZHA-11	20-100 40-200 80-240	0.14 0.25 0.4	- P P.R.	6.4 6.4 6.4	6.19 6.4 6.4	3.69 6.4 6.4	2.23 6.4 6.4	-	-	-	-	-	-	-	-	-	-	-	
	ZHA-22	20-100 40-200 80-240	0.14 0.25 0.4	- P P.R.	-	-	-	-	1.43 6.4 6.4	0.87 5.68 6.4	-	-	-	-	-	-	-	-	-	
	ZHA-23	20-100 40-200 80-240	0.14 0.25 0.4	- P P.R.	-	-	-	-	-	-	0.56 8.64 5.04	0.35 2.30 3.18	-	-	-	-	-	-	-	
	ZHA-34	20-100 40-200 80-240	0.14 0.25 0.4	- P P.R.	-	-	-	-	-	-	-	-	0.34 3.06	0.22 1.98	0.174 0.91 1.26	-	-	-	-	
	ZHA-45	20-100 40-200 80-240	0.14 0.25 0.4	- P P.R.	-	-	-	-	-	-	-	-	-	-	-	-	0.15 1.32	1.10 0.92	0.06 0.52	
	气 开 式 Gas open	ZHB-11	20-100 40-200 80-240	0.14 0.25 0.4	- P P.R.	4.64 6.4 6.4	3.09 6.4 6.4	1.98 5.94 6.4	1.11 3.34 6.4	-	-	-	-	-	-	-	-	-	-	-
		ZHB-22	20-100 40-200 80-240	0.14 0.25 0.4	- P P.R.	-	-	-	-	0.71 2.14 4.99	0.44 1.31 3.05	-	-	-	-	-	-	-	-	-
		ZHB-23	20-100 40-200 80-240	0.14 0.25 0.4	- P P.R.	-	-	-	-	-	-	0.28 0.84 1.95	0.18 0.53 1.25	-	-	-	-	-	-	-
		ZHB-34	20-100 40-200 80-240	0.14 0.25 0.4	- P P.R.	-	-	-	-	-	-	-	-	0.17 0.51 1.18	0.11 0.33 0.78	0.17 0.21 0.5	-	-	-	
		ZHB-45	20-100 40-200 80-240	0.14 0.25 0.4	- P P.R.	-	-	-	-	-	-	-	-	-	-	-	-	0.07 0.22 0.51	0.05 0.15 0.36	0.03 0.09 0.21

注：P-阀门定位器 R-1: 2气动继动器
Note: P - valve positioner R - 1:2 pneumatic servomotor

外形尺寸 Physical size

单位 unit: mm

公称通径(mm) Nominal diameter	ΦA	L	H		
			常温型 Cold type	热片型 hot strip type	
20	285	100	421	586	
25		115	428	587	
32		130	430	592	
40		130	470	629	
50		150	478	639	
65		170	504	765	
80		360	190	608	765
100			215	618	805
125			250	785	1003
150			275	800	1018
200	470	325	832	1038	

ZM_B^AT-10型气动薄膜隔膜调节阀为无填料函结构、节流元件为弹性隔膜，阀体流道平滑；阀体衬里和隔膜均可采用耐腐蚀材料制造，适用于控制各种腐蚀性和悬浮液介质的调节场合。
产品符合GB/T4213-1992。

ZM_B^AT - 10 type pneumatic film diaphragm valve for no stuffing box structure, throttle element for elastic diaphragm, body runner smooth; Body lining and diaphragm are can use corrosion resistant materials manufacturing, applicable to control all kinds of corrosive and suspending liquid medium control occasions.

Products comply with GB/T4213-1992.

主要技术参数 Main technical parameters

公称直径(mm) Nominal diameter	15	20	25	32	40	50	65	80	100
阀座直径(mm) Seat diameter	8	12	16	28	60	68	90	160	300
流量特性 Characteristics	近似快开特性 Approximate quick opening characteristics								
公称压力(MPa) Nominal pressure	1.0								
连接型式 Connection type	法兰连接: PN1.0按JB78-59标准 Flange even by: PN1.0 according to JB78-59 standard								
执行机构型号 With actuator type	ZM _B ^A -2			ZM _B ^A -3			ZM _B ^A -4		
有效面积Fe(cm ²) Effective area	280			400			630		
行程L(mm) stroke	10			16			25		40
作用方式 Mode of action	气关式; 气开式 Gas close type; Gas open type								
弹簧压力范围(KPa) Spring pressure range	标准20-100, 可选用40-200、20-60、60-100 standard 20-100, Can choose 40-200, 20-60, 60-100								
供气压力(MPa) Gas supply pressure	标准0.14; 可选用0.24 standard 0.14; Can choose 0.24								
气源接头 Air joint	M16×1.5								
固有可调比R Inherent Rangesability	30: 1								

项目 project	不带阀门定位器 Don't take valve positioner	带阀门定位器 Take the valve positioner
基本误差% Basic main difference	±10	≤±1
回差% Return difference	≤8	≤1
死区% Dead zone	≤6	≤0.4
泄漏量 leakage	0.01% × 阀额定容量 0.01% × Valve rated capacity	
额定流量系数误差% Rated flow coefficient of the error	≤±10	

阀体衬里和隔膜材料的组合 Body lining and diaphragm combination of materials

阀体材料 Body material	衬里材料 Lining material	隔膜材料 Diaphragm material	使用温度 Using temperature	适用场合 Applicable occasions
铸铁HT200 Cast iron HT200	无 NO	氯丁橡胶 Chloroprene rubber	0-65℃	无腐蚀性介质、水及研磨、泥浆类介质 No corrosive medium, water and grinding, mud class medium
铸铁HT200 Cast iron HT200	聚三氟氯乙烯 Polytrifluorochloroethylene	氟橡胶 Fluorine rubber	-15-150℃	强酸、强碱、强氧化剂和一般有机溶剂， 不适用于泥浆介质 Strong acid, strong alkali, strong oxidizing agent general organic solvent does not apply to mud medium
铸不锈钢 ZG1Cr18Ni9Ti Cast stainless steel	无 NO	氟橡胶 Fluorine rubber	-20-200℃	一般酸、碱有机溶剂等介质 General acid, alkali organic solvent, and other media

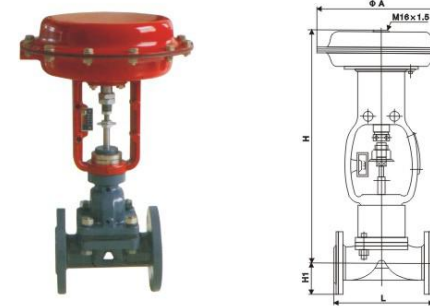

允许压差 Allow differential pressure

使用情况 use situation	信号压力(KPa) Signal pressure		120		140	
	公称直径(mm) Nominal diameter	执行机构有效面积(cm ²) Actuator effective area	关闭时允许最大压力(MPa) Closed to allow maximum pressure			
	15	280	0.9	1.0	0.45	0.9
	20	280	0.9	1.0	0.45	0.9
	25	280	0.4	0.8	0.2	0.4
	32	400	0.4	0.8	0.2	0.4
	40	400	0.3	0.6	0.15	0.3
	50	400	0.2	0.4	0.1	0.2
	65	630	0.2	0.4	0.1	0.2
	80	630	0.1	0.2	0.05	0.1
	100	630	0.05	0.1	0.02	0.05

外形尺寸 Physical size

公称直径(mm) Nominal diameter	φA	L	H		H1
			ZMAT型	ZMBT型	
15	280	140	479	532	47.5
20		145	479	532	52.5
25		155	479	532	57.5
32	325	165	538	617	67.5
40		190	553	632	72.5
50		210	562	641	80
65	410	240	754	855	90
80		270	775	876	97.5
100		335	857	958	107.5

注: 法兰按JB78《铸钢法兰》标准规定。 Note: the flange according to JB78 the (cast iron flanges) standard.

订货须知 Order instructions

订货时请填写《规格书》或注明以下内容:

1. 产品型号
2. 公称通径DN, 公称压力PN
3. 信号压力, 弹簧范围
4. 流量特性, 阀前后压力
5. 流体介质名称
6. 阀体、隔膜材质
7. 是否带附件, 说明型号
8. 介质工作温度范围
9. 其它特殊要求

When ordering, please fill in 《specification》 or indicate the following contents:

1. The product model
2. Nominal diameter DN, nominal pressure PN
3. Signal pressure, spring range
4. Flow characteristic, valve and pressure
5. Fluid medium all kinds of
6. The valve body, the diaphragm material
7. Whether or not to bring a accessories, description model
8. Medium operating temperature range
9. Other special requirements

概述

气动薄膜低温调节阀是单、双座调节阀的变形产品。它与常温调节阀不同之处在于采用长颈型上阀盖，使填料处于常温下工作。适用于-60--250℃低温状态下的介质(如液氧、液氮等)的调节。为确保调节精度，必须配用阀门定位器。
产品符合GB/T4213-1992。

overview

Pneumatic film low temperature control valve is single, double beat regulator deformation products. It with normal temperature regulator different lies 4in the long neck type on the valve cover, make packing in work under normal temperature. Suitable for -60 -- 250 ℃ low temperature condition of the medium (such as liquid oxygen, liquid nitrogen, etc.) regulation. To ensure that the control precision, we must with valve positioner.
Products comply with GB/T4213-1992.

结构原理

气动薄膜低温调节阀是由气动薄膜执行机构和耐低温的单、双座阀两部分组成。
由调节器来的信号压力输入气动薄膜执行机构的气室，产生推力，通过连接杆件带动阀芯，阀芯位置的变化使阀的流通截面积变化，实现对介质流量的调节。

Structure principle

Pneumatic film low temperature control valve is by pneumatic diaphragm actuator and low temperature resistance of single, double beat valve of two parts.
The regulator to signal pressure input pneumatic diaphragm actuator's gas chamber, produce thrust, through the connection link drive valve core and valve core position of the change of valve circulation sectional area change, realize the medium flow control.

主要技术指标 The main technical index

公称口径 (mm) Nominal diameter	单座 single seat	G3/4"										20	25	32	40	50	65	80	100	125	150	200	
	双座 two seater											25	32	40	50	65	80	100	125	150	200		
额定流量系数 Kv Rated flow coefficient	单座 single seat	0.08	0.12	0.20	0.32	0.50	0.80	1.2	2.0	3.2	5.0	8	12	20	32	50	80	120	200	280	450		
	双座 two seater											10	6	25	40	63	100	160	250	400	630		
流量特性 Characteristics		直线 Straight line										直线：每百分比 Straight line; Equal percentage											
执行机构型号 With actuator type		ZM ^A _B -22										ZM ^A _B -22			ZMA-23		ZMA-34		ZMA-45				
行程 stroke		10										16			25		40			60			
作用方式 Mode of action		气关式(B), 气开式(K) Gas close type, Gas open type																					
弹簧压力范围(KPa) Spring pressure range		标准信号: 20-100; 其它信号: 40-200; 20-60; 60-100 Standard signal: 20-100; Other signal: 40-200; 20-60; 60-100																					

安装、使用注意事项

1. 应垂直安装在水平管道上，在特殊情况下需要水平或倾斜安装时，一般应加支撑。装在保温箱壁的隔板与保温箱壁应平行。
2. 应安装在靠近地面或楼板的地方，以便于维护检修，对装有阀门定位器或手轮机构者，更应保证观察，调整和操作的方便。
3. 一般都设置旁通管路，以便在自控系统发生故障或维修调节阀时切换到手动操作，不致于停止生产。
4. 装有手轮机构时，也可省略旁通管路时行手动操作，还可用于限制阀门的开启。当停止使用时，手轮机构必须恢复到原来空档位置，以利自控系统正常进行。
5. 安装时，应使介质流向与阀体指示方向一致。
6. 调节阀在安装前应对管路清洗污物、焊渣。安装后，使调节阀全开，对管路，阀门进行清洗及试验各连接处的密封性。

Installation and use the matters needing attention

1. should be installed vertically in horizontal pipe runs, in special cases need level or tilted installation, general should add support. Loading from the box wall garden plate and heat preservation box wall should be parallel.
 2. should be installed in the close to the ground or floor place, in order to maintenance overhaul, with valve positioner or the handwheel agency person, more should guarantee observation, adjustment and operation convenience.
 3. usually set bypass line, so that in the automatic control system malfunction or maintenance regulator with switch to manual operation, not to stop production.
 4. equipped with handwheel mechanism, also can be omitted the by-pass line be fashionable manual operation, but also can be used to limit the valve opening. When to stop the use, the handwheel mechanism must be restored to the original neutral position, and automatic control system normal.
 5. installation, should make the flow direction of medium and body indicating direction.
 6. regulating valve in before the installation, should line cleaning dirt, welding slag. After installation, make valve fully open, the line, the valve for cleaning and try.
- Check each joint sealing.

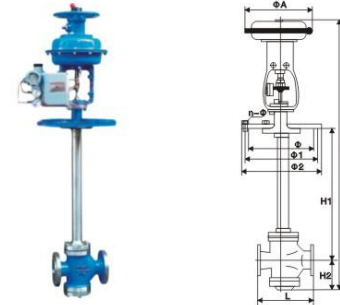

外形尺寸 Physical size

公称口径(mm) Nominal diameter	3/4"	20	25	32	40	50	65	80	100	125	150	200		
A	φ230	φ280	φ280			φ325		φ410			φ495			
φ	135	235	255	255	280	310	345	370	430	470	550	660		
φ1	160	260	260	285	305	340	375	405	460	525	590	700		
φ2	190	290	290	315	335	370	410	440	490	560	630	740		
n-φ	6-12	8-14	8-14	8-14	8-16	8-16	10-16	10-18	12-18	16-18	16-18	20-18		
单座 single seat	H	PN40 L	190	200	200	210	230	255	285	310	355	425	560	
		H1=500	862	1006	1060	1066	1137	1152	1377	1390	1394	-	-	
		H1=600	962	1106	1160	1166	1237	1252	1477	1490	1494	-	-	
		H1=700	1062	1206	1260	1266	1337	1352	1577	1590	1594	1743	1751	1790
		H1=800	1162	1306	1360	1366	1437	1452	1677	1690	1694	1843	1851	1890
		H1=900	1262	1406	1460	1466	1537	1552	1777	1790	1794	1943	1951	1990
		H1=1000	1362	1506	1560	1566	1637	1652	1877	1890	1894	2043	2051	2090
		H1=1100	-	-	-	-	-	-	-	-	-	2143	2150	2190
		H1=1200	-	-	-	-	-	-	-	-	-	2243	2250	2290
		H2	32	58	112	118	129	144	178	191	195	243	251	290
		双座 two seater	H	PN64 L	200	210	235	265	295	320	370	440	475	570
				H1=500	-	-	1065	1068	1147	1152	1387	1407	1419	-
H1=600	-			-	1165	1168	1247	1252	1487	1507	1519	-	-	
H1=700	-			-	1265	1268	1347	1352	1587	1607	1619	1768	1778	1820
H1=800	-			-	1365	1368	1447	1452	1687	1707	1719	1868	1878	1920
H1=900	-			-	1465	1468	1547	1552	1787	1807	1819	1968	1978	2020
H1=1000	-			-	1565	1568	1647	1652	1887	1907	1919	2068	2078	2120
H1=1100	-			-	-	-	-	-	-	-	-	2168	2178	2220
H1=1200	-			-	-	-	-	-	-	-	-	2268	2278	2320
H2	-			-	117	120	139	144	188	208	208	268	278	320

注：法兰尺寸：按JB78-59《铸钢法兰》PN64的规定。 Note: the flange size: according to JB78-59 《cast steel flange》 of the provisions of the PN64. 订货须知

1. 产品型号 2. 公称压力PN 3. 公称口径DN 4. 工作温度 5. 额定流量系数Kv 6. 固有流量特性 7. 作用方式 8. 弹簧范围 9. 阀体、阀内件材料 10. 附件：如空气过滤器减压阀、阀门定位器(气动、电气)阀位开关、保位阀、手轮机构等选择或成套备件

Order instructions

1. The product model 2. Nominal pressure PN 3. Nominal diameter DN 4. Working temperature 5. The rated flow coefficient Kv 6. The intrinsic flow feature of 7. Mode of action 8. Spring range 9. The valve body, valve internals material accessories: such as air filtration pressure relief valve, the valve locator (pneumatic, electrical) valve position switch, protect a valve, the handwheel institutions choose complete set of spare parts



ZMA_X型气动薄膜三通调节阀 ZMA_Xtype pneumatic film three-way valve

概述

ZMA_X型气动薄膜三通调节阀有合流和分流两种作用方式。阀芯结构采用圆筒薄壁窗口, 并采用阀芯侧面导向。三通阀在某些场合可以替代两个二通阀和一个三通接管而得到广泛应用, 常用于热交换器的两相调节, 也可用于简单的配比调节。
产品符合GB/T4213-1992。

overview

ZMA_Xtype pneumatic film three-way valve have Interflow and shunt two ways. Valve core structure using cylindrical thin wall window, and USES the valve core side guide. Three-way valve in some occasions can replace two two-way valve and a tee over and used widely, and often used in heat exchanger of two phase adjustment, can also be used to simple ratio regulation.
Products comply with GB/T4213-1992.

主要技术参数和性能指标 The main technical parameters and performance index

调节机构主要技术参数 Regulatory agency main technical parameters

公称通径 (mm) Nominal diameter	合流 Interflow	25	32	40	50	65	80	100	125	150	200	250	300	
	分流 shunt						80	100	125	150	200	250	300	
额定流量 系数KV Rated flow coefficient	合流 Interflow	8.5	13	21	34	52	85	135	210	340	535	800	1260	
	分流 shunt						85	135	210	340	535	800	1260	
公称压力(MPa) Nominal pressure		1.6 4.0 6.4												
行程(mm) stroke		16		25			40			60			100	
流量特性 Characteristics		直线 linear												
介质温度℃ Medium temperature		-20~+200、-40~+250(常温型) -40~+45(中温型) -20~+200、-40~+250(Cold type) -40~+45(Medium temperature type)												
法兰尺寸 Flange size		铸铁法兰尺寸按JB78 铸钢法兰尺寸按JB79 Cast iron flange size according to JB78 cast steel flange dimension regulation according to JB79												
法兰型式 Flange type		法兰密封面型式按JB77, 其中铸铁法兰按光滑式铸钢法兰按凹式 Flange sealing surface pattern according to JB77, including cast iron flange according to smooth type cast steel flange by concave type												
阀体材质 Body material		HT200、WCB、ZG1Cr18Ni9Ti												
阀芯材质 Valve core material		1Cr18Ni9												
上阀盖型式 On valve cover type		普通式(常温型), 热片式(中温型) Common type (cold type), hot plate (medium temperature type)												
可调比R Rangeability		30: 1												

执行机构主要技术参数 Actuator main technical parameters

型号 Type	ZMA/ZMB-3	ZMA/ZMB-4	ZMA/ZMB-5	ZMA/ZMB-6
有效面积(cm ²) Effective area	400	630	1000	1600
行程(m) stroke	16, 25	40	60	100
弹簧压力范围(KPa) Spring pressure range	20-100; 40-200; 20-60; 60-100、80-240			

ZMA_X型气动薄膜三通调节阀 ZMA_Xtype pneumatic film three-way valve



性能指标Performance index

项目 project	不带定位器 Don't take positioner	带定位器 Take the positioner		
基本误差% Basic main difference	±6	±1.5		
回差% Return difference	5	≤1.5		
死区% Dead zone	4	≤0.6		
始/终点偏差% Always point deviation	气开 Gas open	始点 Initial point	±2.5	±1.5
		终点 end	±6.0	
	气关 Gas shut	始点 Initial point	±6.0	
		终点 end	±2.5	
额定行程% Rated stroke	±2.5			
允许泄漏量L/h Allow leakage	10 ⁻⁴ × 阀额定容量 10 ⁻⁴ × Valve rated capacity			

注: 一般均应带定位器 Note: general all should take locator

允许压差 Allow differential pressure

气源压力 MPa Air pressure	弹簧范围 KPa Spring range	公称通径(mm) Nominal diameter											
		25	32	40	50	65	80	100	125	150	200	250	300
0.14	20-100	1220	750	500	300	300	200	120	120	80	50	50	25

可配附件 Can match accessories

定位器、手轮机构、空气过滤减压器等。
Locator, hand wheel mechanism, air filtration pressure reducer, etc.

主要零件材料 The major parts material

零件名称 Part name	材料 material	温度范围 Temperature range
阀体 上、下阀盖 body Upper and lower valve cover	HT200	-15~+200℃
	WCB	-29~+250℃
	ZG1Cr18Ni9Ti	-40~+550℃
阀座、阀芯、阀杆 The seat, valve core, the valve stem	1Cr18Ni9	-40~+550℃
密封垫 gasket	橡胶石棉板 Rubber asbestos board	
	不锈钢缠绕垫 Stainless steel wound gasket	
填料 packing	聚四氟乙烯 teflon	
上、下膜盖 Upper and lower membrane cover	A3钢板 A3 steel	
螺栓、螺母 Bolt, screw	35CrMoA	
螺母 nut	35	
支架、顶盖 Bracket, terminal disc	HT200、WCB、ZG1Cr18Ni9Ti	
压缩弹簧 Compression spring	60Si2Mn	
波纹薄膜 Corrugated film	5860胶夹48D尼龙66网眼布 5860 glue clamp 48D nylon 66 mesh cloth	

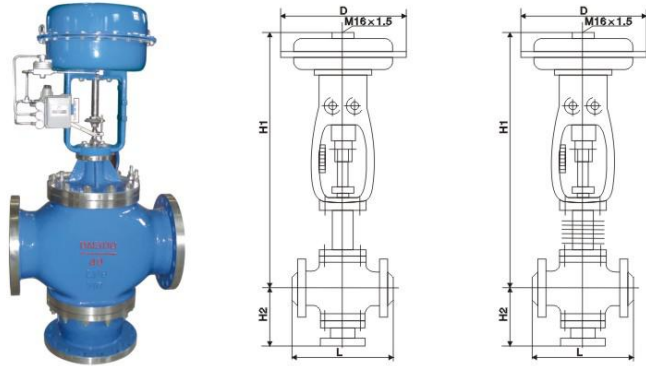

外形尺寸 Physical size

公称 口径 (mm) Nominal diameter	行程 stroke	D	合流 Interflow						分流 shunt											
			L			H ₁			H ₂			L			H ₁			H ₂		
			PN(MPa)			常温型 Cold type	中温型 Medium type	高温型 Hot type	PN(MPa)			常温型 Cold type	中温型 Medium type	高温型 Hot type	PN(MPa)			常温型 Cold type	中温型 Medium type	高温型 Hot type
			1.6	4.0	6.4				1.6	4.0	6.4				1.6	4.0	6.4			
25	16	325	185	190	200	615	763	140	150	150	185	190	200	615	763	140	150	160		
32	16	325	200	200	210	622	773	150	160	170	200	200	210	622	773	150	160	170		
40	25	325	220	220	235	625	776	160	170	180	220	220	235	625	776	160	170	180		
50	25	325	250	255	265	640	791	180	190	200	250	255	265	640	791	180	190	200		
65	40	410	275	285	295	861	1024	200	210	220	275	285	295	861	1024	200	210	220		
80	40	410	300	310	320	879	1042	210	230	240	300	310	320	885	1050	225	250	265		
100	40	410	350	360	370	873	1036	220	250	260	350	360	370	900	1060	245	275	285		
125	60	495	410	430	440	1029	1244	260	300	300	410	430	440	1050	1265	285	320	325		
150	60	495	450	465	475	1046	1261	280	320	320	450	465	475	1060	1275	305	340	345		
200	60	495	550	560	570	1075	1290	320	380	380	550	560	570	1105	1320	350	400	410		
250	100	600	640	660	670	1451	1320		474	474	635	660	670	1525	2800		540	540		
300	100	600	740	760	770	1512	1560		584	584	720	740	770	1545	1820		612	612		

注：公称口径小于80的分流阀采用同口径的合流阀代替。
Note: nominal diameter less than 80 diverter valve used with diameter of confluence valve instead of.

订货须知

订货时请填写《规格书》或注明以下内容：
1、产品型号 2、公称口径、额定流量系数 Kv 3、信号压力、弹簧范围 4、流量特性 5、阀的开关方式 6、介质种类 7、介质工作温度范围 8、阀体、阀盖、套筒材质 9、是否带手轮机构及定位器、并说明型号 10、是否有其它特殊要求

Order instructions

When ordering, please fill in 《specification》 or indicate the following contents:
1.product model 2.nominal diameter, rated flow coefficient Kv 3.signal pressure, spring range 4.flow characteristic 5.valve switch mode 6.Medium type 7.kinds of medium, medium operating temperature range 8.the valve body, valve plug, sleeve material 9.whether or not to bring a handwheel institutions and locator, and explain the model 10.of whether any other special requirements

特点和用途

ZSJP型精小型气动活塞式单座调节阀是由ZS^A-P型 弹簧活塞式可调执行机构和精小型单座阀组件组成，结构比ZJHP型轻小，动作速度快，抗震性好，流通能力大，选用不同的弹簧范围可以获得需要的许用压差，适用于泄漏量要求小，或安装空间受限制或要求响应速度快的自控场合。气动活塞式调节阀均带定位器。其调节切断型产品为2sJP3，阀芯、阀座堆焊司太素硬质合金，允许泄漏量为10⁻⁶×阀额定容量。

Characteristics and USES

ZSJP type fine small pneumatic piston type single seat regulator is by ZS^A-P type spring piston type adjustable actuator and fine small single seat valve component, structure than ZJHP type light small, movement speed, earthquake resistance good, flow capacity big, choose different spring range can get need allowable pressure difference, applicable to small leakage requirements, or installation space restricted or require response speed control occasions. Pneumatic piston valve are equipped with locator. The control cutting type products for 2sJP3, valve core and valve seat overlaying welding company too food carbide, allowing the leakage is 10⁻⁶× valve rated capacity.

主要技术参数 Main technical parameters

公称口径(mm) Nominal diameter		20		25	40	50	65	80	100	150	200				
阀座直径(mm) Seat diameter		10	12	15	20	25	32	40	50	65	80	100	125	150	200
额定流量系数Kv Rated flow coefficient	直线 Straight line	1.8	2.8	4.4	6.9	11	17.6	27.6	44	69	110	176	275	440	690
	等百分比 equal percentage	1.6	2.5	4	6.3	10	16	25	40	63	100	160	250	400	630
执行机构 actuator	型号 Type	ZS ^A -2P				ZS ^A -3P			ZS ^A -4P			ZS ^A -5P			
	气缸直径 Cylinder diameter	125				160			200			250			
	行程(mm) stroke	16				25			40			60			
	弹簧范围KPa Spring range	气关式：40~200，气开式：80~240, 100~200, 200~350, 350~500 Gas close type: 40~200, Gas close type: 80~240, 100~200, 200~350, 350~500													
流量特性 Characteristics	直线，等百分比 Straight line, equal percentage														
可调比 Rangeability	R=50:1														
公称压力(MPa) Nominal pressure	1.6; 4.0; 6.4														
上阀盖型式 On valve cover type	普通式(常温型)；热片式(中温型) Common type (cold type); Hot plate (medium temperature type)														
介质温度℃ Medium temperature	-40~250(常温型)，-40~450(中温型) -40~250(cold type), -40~450(medium temperature type)														
法兰标准 Flange standards	JB79-59，密封面形式：PN16为光滑式；PN40,64为凹式 JB79-59, sealing surface forms: PN16 for smooth type; PN40, 64 is the concave type														

性能指标(带定位器) Performance index (with locator)

项目 project	指标值 Index value	项目 project		指标值 Index value
基本误差% Basic main difference	±1.0	气关 Gas shut	始点 Initial point	±1.0
回差% Return difference	1.0		终点 end	
死区% Dead zone	≤0.4		气开 Gas open	始点 Initial point
额定流时系数误差% Rated flow coefficient of the error	+2.5	终点 end		
		允许泄漏量L/h Allow leakage		1×10 ⁻⁶ 阀额定容量 1×10 ⁻⁶ Valve rated capacity

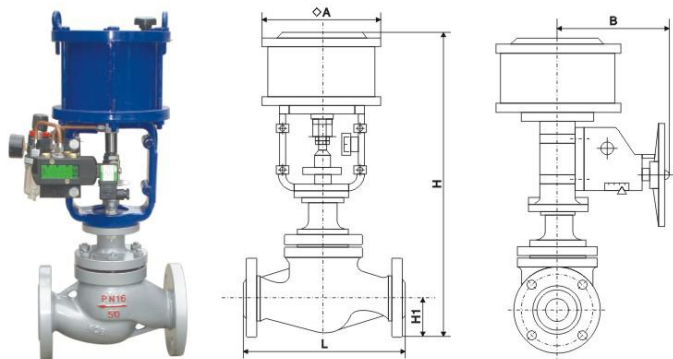

允许压差 Allow differential pressure

气源压力 Mpa Air pressure	公称口径(mm) Nominal diameter	弹簧范围(MPa) Spring range																																			
		20				25		40		50		65		80		100		150		200																	
0.25	40-200	2.9	2.5	1.6	0.9	0.73	0.8	0.6	0.31	0.29	0.19	0.12	0.13	0.09	0.05	5.9	5.0	3.2	1.8	1.47	1.6	1.2	0.62	0.59	0.39	0.24	0.27	0.18	0.10								
0.30	80-240	6.4	6.4	6.4	4.5	3.68	4.0	2.6	1.56	1.48	0.98	0.62	0.78	0.74	0.49	0.31	0.34	0.22	0.123	6.4	6.4	6.4	4.5	3.68	4.0	2.6	1.56	1.48	0.98	0.62	0.78	0.74	0.49	0.31	0.34	0.22	0.123
0.25	100-200	6.4	6.4	6.4	4.5	3.68	4.0	2.6	1.56	1.48	0.98	0.62	0.78	0.74	0.49	0.31	0.34	0.22	0.123	6.4	6.4	6.4	4.5	3.68	4.0	2.6	1.56	1.48	0.98	0.62	0.78	0.74	0.49	0.31	0.34	0.22	0.123
0.40	200-350	6.4	6.4	6.4	4.5	3.68	4.0	2.6	1.56	1.48	0.98	0.62	0.78	0.74	0.49	0.31	0.34	0.22	0.123	6.4	6.4	6.4	4.5	3.68	4.0	2.6	1.56	1.48	0.98	0.62	0.78	0.74	0.49	0.31	0.34	0.22	0.123
0.55	350-500	6.4	6.4	6.4	4.5	3.68	4.0	2.6	1.56	1.48	0.98	0.62	0.78	0.74	0.49	0.31	0.34	0.22	0.123	6.4	6.4	6.4	4.5	3.68	4.0	2.6	1.56	1.48	0.98	0.62	0.78	0.74	0.49	0.31	0.34	0.22	0.123

注：1.表列数据为气开式流开型，选用气关式时气源压力应为弹簧范围的（上限+下限）×1.1

2.选用压差超过1MPa时阀芯阀座表面应堆焊硬质合金或改用其它材料

Note: 1. The tabular data for gas open flow open type, choose gas shut when type air pressure should be spring range of (cap + floor) x 1.1

2. Choose differential pressure more than 1 MPa when valve core seat surface should be surfacing carbide or to switch to other materials

外形尺寸和重量 Physical size and weight

公称口径 (mm) Nominal diameter	◇A	Lmm			Hmm		H1			重量kg weight	
		PN16	PN40	PN64	常温 cold	中温 Medium temperature	PN16	PN40	PN64	PN16	PN40,64
20	148 x 148	181	194	206	371	521	52.5	52.5	65	16	20
25		184	197	210	383	533	57.5	57.5	67.5	17	21
40	185 x 1 85	222	235	251	423	588	72.5	72.5	82.5	20.4	29.4
50		254	267	286	450	596	80	80	87.5	24.4	34.4
65	232 x 232	276	292	311	582	762	90	90	100	42	61
80		298	317	337	594	779	97.5	97.5	105	50	73
100	283 x 283	352	368	394	612	810	107.5	115	125	80	94
150		451	473	508	787	1047	140	150	170	120	140
200		600	600	650	807	1067	167.5	187.5	202.5	1 80	201

注：1. 中温型重量增加20%；2. 气信号接口为ZG1/4"。 Note: 1. The medium temperature type a 20% increase in weight; 2. Gas signal interface for ZG1/4".

主要零件材质及可用温度范围 The major parts material and usable temperature range

阀体、上阀盖 The valve body, valve cover	ZG230-450	-40~+450℃
	ZG1Cr18Ni9Ti	-250~+550℃
	ZG0Cr18Ni12Mo09Ti	-250~+550℃
阀芯、阀座 Valve core and valve seat	1Cr18Ni9	-250~+550℃
	0Cr18Ni12Mo2Ti	-250~+550℃
填料 packing	聚四氟乙烯 teflon	-40~+200℃
	柔性石墨 Flexible graphite	-200~+600℃
活塞环 Piston ring	TPU、丁腈橡胶 Nitrile rubber	
压缩弹簧 Compression spring	60Si2MnA	
气缸 cylinder	铝合金精拉管，硬阳极氧化 Aluminum alloy essence drawn tube, hard anodize oxidation	

可配带附件 May be installed with accessories

型号 Type	名称 name	备注 note
QFH-261	空气过滤减压阀 Air filtering pressure reducer	
或QGJ-121		
ZPQ	气动阀门定位器 Pneumatic valve positioner	20~100KPa
或ZPD	电-气阀门定位器 Electric in valve positioner	0~10mA, 4~20mA
ZPB-121 127	气动保位阀 Pneumatic protect a valve	根据输出压力 According to the output pressure
ZPXS	侧装手操机构 Side mount hand operating mechanism	本厂生产 The factory production

型号编制说明 Model establishment that

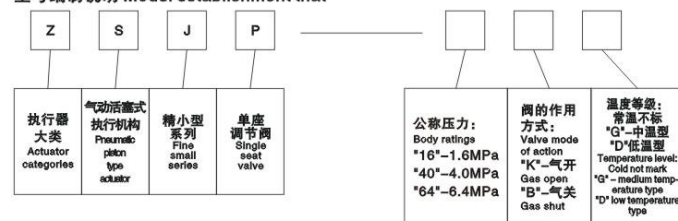

订货须知 Order instructions

1. 产品型号
2. 公称压力
3. 公称口径，额定流量系数Kv
4. 弹簧范围
5. 流量特性
6. 阀的开关方式
7. 介质工作温度范围
8. 阀体、阀芯、阀座材料
9. 是否带附件，说明附件型号
10. 是否有其他特殊要求

1. The product model
2. Nominal pressure
3. Nominal diameter, frontal quantitative factor Kv
4. Spring range
5. Flow characteristic
6. Valve switch mode
7. Medium operating temperature range
8. The valve body, valve core and valve seat materials
9. Whether or not to bring a accessories, explain accessories model
10. Is there any other special requirements

特点和用途

ZSJM型精小型气动活塞式套筒调节阀是由ZSA-P型弹簧活塞式可调零执行机构和精小型套筒阀组件组成，结构比ZJHM更轻小。阀芯采用平衡式结构，许用压差大，抗振性好，噪声低，稳定性好，拆装简单，选择不同的弹簧范围可获得需要的许用压差。

应用于要求噪声低，工作压力大或安装位置受限制或要求响应速度快的工业生产过程的自控系统中。
气动活塞式套筒调节阀均带阀门定位器。

Characteristics and USES

ZSJM type fine small pneumatic piston sleeve valve is by ZSA-P type spring piston type adjustable zero actuators and the fine small set of Jane valve component, structure ZJHM lighter than small. Valve core using balanced structure, allowable pressure difference is big, vibration resistance good, low noise, good stability, load and simple, choose a different spring range can gain access to allowable pressure difference.

Applied to request low noise, work pressure difference big or installation location restricted or require response speed of industrial production process automatic control system.

Pneumatic piston sleeve valve are equipped with valve positioner.

主要技术参数 Main technical parameters

公称通径(mm) Nominal diameter		20		25	40	50	65	80	100	150	200				
阀座直径mm Seat diameter		10	12	15	20	25	32	40	50	65	80	100	125	150	200
额定流量系数Kv Rated flow coefficient	直统 Straight line	1.8	2.8	4.4	6.9	11	17.6	27.6	44	69	110	176	275	440	690
	等百分比 equal percentage	1.6	2.5	4	6.3	10	16	25	40	63	100	160	250	400	630
执行机构 actuator	型号 Type	ZS _B -2P				ZS _B -3P				ZS _B -4P			ZS _B -5P		
	气缸直径 Cylinder diameter	125				160				200			250		
	行程mm stroke	16				25				40			60		
	弹簧范围KPa Spring range	气关式: 40~200, 气关式: 80~240, 100~200, 200~350, 350~500 Gas close type: 40~200, Gas close type: 80~240, 100~200, 200~350, 350~500													
流量特性 Characteristics	直统, 等百分比 Straight line, equal percentage														
可调比 Rangeability	R=50:1														
公称压力(MPa) Nominal pressure	1.6; 4.0; 6.4														
上阀盖型式 On valve cover type	普通式(常温型); 热片式(中温型) Common type (cold type); Hot plate (medium temperature type)														
介质温度℃ Medium temperature	-40~250(常温型), -40~450(中温型) -40~250(cold type), -40~450(medium temperature type)														
法兰标准 Flange standards	JB79-59, 密封面形式: PN16为光滑式; PN40, 64为凹式 JB79-59, sealing surface forms: PN16 for smooth type; PN40, 64 is the concave type														

性能指标 (不带定位器) Performance index (without locator)

项目 project	指标值 Index value	项目 project		指标值 Index value
基本误差% Basic main difference	±1.0	始终点偏差% Always point deviation	气开 Gas open	±1.0
回差% Return difference	1.0		始点 Initial point	
死区% Dead zone	≤0.4		终点 end	
额定行程偏差% Rated stroke deviation	+2.5		气关 Gas shut	
			始点 Initial point	
			终点 end	
		允许泄漏量L/h Allow leakage		1×10 ⁻⁸ 阀额定容量 Valve rated capacity

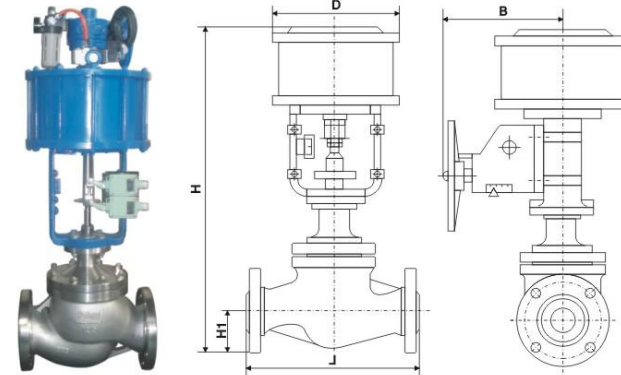

允许压差 Allow differential pressure

气源压力 Air pressure Mpa	公称通径(mm) Nominal diameter	20		25		40		50	65	80	100	150		200
		20	25	(32)	(40)	(125)	(150)							
0.25	40~200	0.37	6.4	6.4	6.4	5.7	4.2	3.3	2.4	2.5	1.8	1.3		
0.30	80~240	6.4	6.4	6.4	6.4	6.4	6.4	6.4	6.4	5.0	3.6	2.6		
0.25	100~200	6.4	6.4	6.4	6.4	6.4	6.4	6.4	6.4	6.4	4.5	3.2		
0.40	200~350	6.4	6.4	6.4	6.4	6.4	6.4	6.4	6.4	6.4	6.4	6.4		
0.55	350~500	6.4	6.4	6.4	6.4	6.4	6.4	6.4	6.4	6.4	6.4	6.4		

注: 1. 表列数据为气开式流开型, 选用气关式时气源压力应为弹簧范围的(上限+下限)×1.1

2. 选用压差超过1MPa时阀芯阀座表面应堆焊硬质合金或改用其它材料

Note: 1. The tabular data for gas open flow open type, choose gas shut when type air pressure should be spring range of (cap + floor) x 1.1

2. Choose differential pressure when more than 1MPa valve spool valve seat surface should be surfacing carbide or to switch to other materials

外形尺寸和重量 Physical size and weight

公称通径 (mm) Nominal diameter	D	B	Lmm			Hmm		H1			重量kg weight	
			PN16	PN40	PN64	常温 cold	中温 Medium temperature	PN16	PN40	PN64	PN16	PN40
25	148×148	220	184	197	210	383	533	57.5	57.5	67.5	17	21
40	185×185		222	235	251	423	588	72.5	72.5	82.5	20.4	29.4
50			254	267	286	450	596	80	80	87.5	24.4	34.4
65	232×232	280	276	292	311	582	762	90	90	100	42	61
80			298	317	337	594	779	97.5	97.5	105	50	73
100			352	368	394	612	810	107.5	115	125	80	94
150	283×283	350	451	473	508	787	1047	140	150	170	120	140
200			600	600	650	807	1067	167.5	187.5	202.5	180	201

注: 1. 中温型重量增加20%

2. 气信号接口为ZG1/4"

Note: 1. The medium temperature type a 20% increase in weight 2. Gas signal interface for ZG1/4".

主要零件材质及可用温度范围 The major parts material and usable temperature range

阀体上阀盖 The valve body valve cover	ZG230-450	-40~+450℃
	ZG1Cr18Ni9Ti	-250~+550℃
	ZG0Cr18Ni12Mo2Ti	-250~+550℃
阀套、套筒 Plug and socket	1Cr18Ni9	-250~+550℃
	0Cr18Ni12Mo2Ti	-250~+550℃
填料 packing	聚四氟乙烯 teflon	-40~+200℃
	柔性石墨 Flexible graphite	-200~+600℃
活塞环 Piston ring	TPU	
压缩弹簧 Compression spring	60Si2MnA	
气缸 cylinder	铝合金精拉管, 硬阳极氧化 Aluminum alloy essence drawn tube, hard anodic oxidation	

可配带附件 May be installed with accessories

型号 Type	名称 name	备注 note
QFH-261	空气过滤减压阀 Air filtering pressure reducer	
或QGJ-121		
ZPQ	气动阀门定位器 Pneumatic valve positioner	
或ZPD	电-气阀门定位器 Electric in valve positioner	
ZPB-121	气动保位阀 Pneumatic protect a valve	根据输出压力 According to the output pressure
ZPB-127		
ZPXS	侧装手操机构 Side mount hand operating mechanism	本厂生产 The factory production

型号编制说明

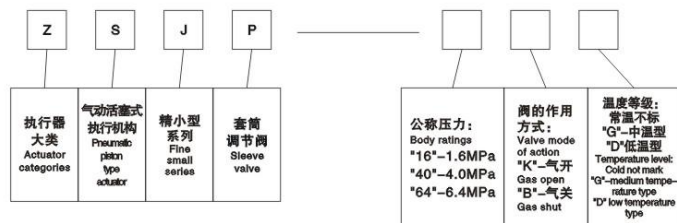

订货须知 Order instructions

1. 产品型号
2. 公称压力
3. 公称直径, 额定流量系数Kv
4. 弹簧范围
5. 流量特性
6. 阀的开关方式
7. 介质工作温度范围
8. 阀体、阀芯、阀座材料
9. 是否带附件, 说明附件型号
10. 是否有其他特殊要求

1. The product model
2. Nominal pressure
3. Nominal diameter, frontal quantitative factor Kv
4. Spring range
5. Flow characteristic
6. Valve switch mode
7. Medium operating temperature range
8. The valve body, valve core and valve seat materials
9. Whether or not to bring a accessories, explain accessories model
10. Is there any other special requirements

结构特点和应用范围

ZMA^P_NB型气动薄膜保温夹套单座调节阀, 当被调介质的结晶温度高于常温 and 因温度降低流体粘度增加或凝固致使阀门动作不灵时, 在单座阀体和上阀盖处采用保温夹套装置, 利用蒸汽进行保温, 该阀主要应用于保持介质温度, 防止介质结晶和凝固的场合。

Structure features and application range

ZMA^P_NB type pneumatic film insulation jacketed single seat valve, when modulated medium crystallization temperature higher than the normal temperature and the temperature to reduce fluid viscosity increase or setting render the valve action hard, in single seat body and the valve cover the insulation jacketed device, the use of steam heat preservation, this valve is mainly used YuBaoTe medium temperature, prevent medium crystal and solidification occasions.

型号、规格 Model、specification

类别 category	普通型 ordinary	堆焊型 Overlaying welding type
型号 model	ZMA ^P _N -40B 64K	ZMA ^P _N -40B 64K B1
规格 specifications	DN25-200	

主要技术参数和性能指标 The main technical parameters and performance index

调节阀主要技术参数 Regulatory agency main technical parameters

公称通径(mm) Nominal diameter	25	32	40	50	65	80	100	125	150	200
额定流量系数Kv Rated flow coefficient	10	16	25	40	63	100	160	250	400	630
公称压力(MPa) Nominal pressure	6.4	6.4 4.0	6.4	4.0	4.0	4.0	4.0	4.0	4.0	
行程(mm) stroke	16		25		40			60		
保温介质温度℃ Insulation medium temperature	≤350									
保温介质压力MPa Insulation medium pressure	1.0									
流量特性 Characteristics	直线, 等百分比 Straight line, equal percentage									
介质温度℃ Medium temperature	-40-350									
法兰尺寸、型式 Flange size, type	按J B/T79.2-94凸式在本规格基础上上升一至三档 According to the J B/T79.2-94 convex type in this specification rise on the basis of one to three files									
阀体材料 Body material	ZG230-450; ZG1Cr18Ni9Ti									
保温套材质 Insulating sheath material	A、钢板 steel plate									

执行机构主要技术参数 Actuator main technical parameters

型号 Type	ZMA-2	ZMA-3	ZMA-4	ZMA-5
薄膜有效面积(cm ²) Film effective area	280	400	630	1000
行程(mm) stroke	16	25	40	60
弹簧范围KPa Spring range	20-100; 40-200; 20-60; 60-100			

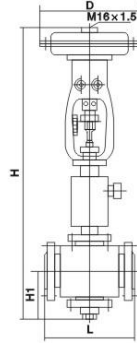

性能指标 Performance index

项目 project	指标值 Index value
基本误差% Basic main difference	±2.5
回差% Return difference	2.5
额定行程偏差% Rated stroke deviation	+2.5
允许泄漏量1/h Allow leakage 1/h	10 ⁻⁴ ×阀额定容量 10 ⁻⁴ ×Valve rated capacity

允许压差 Allow differential pressure

公称直径(mm) Nominal diameter		25	32	40	50	65	80	100	125	150	200	250	300	
薄膜有效面积(cm ²) Film effective area		280		400			630			1000		1600		
允许压差 Allow differential pressure	气源压力KPa Air pressure	允许压差在P2=0, 阀杆在介质流出端状态下 Allow differential pressure in P2 = 0, stem in medium outflow end state												
	气关阀 Gas off valve	120	5.3, 4.3		4.9, 3.8		4.7, 3.6		2.8, 3.7		2.7, 2.1		2.0, 1.7	
	140	6.4												
	180	6.4												
气开阀 Gas open valve	200	5.3, 4.3		4.9, 3.8		4.7, 3.6		2.8, 3.7		2.7, 2.1		2.0, 1.7		
	40~200	6.4												
	80~240	6.4												

可配附件 Can match accessories

定位器、手轮机构、空气过滤减压阀、保位阀等。
Locator, hand wheel mechanism, air filtration pressure reducer, the position valve, etc.

外形尺寸 Physical size

单位 unit: mm

公称直径(mm) Nominal diameter	D	法兰提升槽数 Flange ascension slot number	提升后法兰规格 After lifting flange specifications	L	H	H1
25	280	3	50	265	994	270
32		2,3	50,65	265,276	994	270,280
40		3	80	320	1065	300
50	325	2	80	320	1065	300
65		2	100	380	1402	355
80		2				
100	410	2	150	436	1460	388
125						
150		2	200	580	1803	514
200	495					

工作温度与许用介质压力的关系 Working temperature and allowable medium pressure relationship

材料 material	公称压力 (MPa) Nominal pressure	介质工作温度℃ Medium working temperature													
		<120	<200	<250	<300	<350	<400	<425	<450	<480	<520	<560	<590	<610	<630
HT200	0.6	0.6	0.49	0.44											
	1.6	1.6	1.27	1.09											
ZG230~450	4.0	4.0	3.7	3.3	3.0	2.8	2.3	1.8							
	6.4	6.4	5.9	5.2	4.7	4.1	3.7	2.9							
ZG1Cr18Ni9Ti	0.6	0.6		0.56		0.5			0.45	0.4	0.36	0.32	0.28	0.25	
	1.6	1.6		1.4		1.25			1.1	1.0	0.9	0.8	0.7	0.64	
ZG0Cr18Ni12Mo2Ti	4.0	4.0		3.6		3.2			2.8	2.5	2.2	2.0	1.8	1.6	
	6.4	6.4		5.6		5.0			4.5	4.0	3.6	3.2	2.8	2.5	

主要零件材料的使用温度范围 The major parts the use of material temperature range

材料 material	温度范围℃ Temperature range	备注 note
HT200	-20~200	
QT400-180, QT400-15	-30~350	
ZG230-450	-40~450	
ZG1Cr18Ni9Ti, ZG0Cr18Ni12Mo2Ti	-250~550	
2Cr13	-20~450	
1Cr18Ni9	-196~550	
0Cr18Ni12Mo2Ti	-196~600	
聚四氟乙烯 teflon	-40~200	
碳纤维 Carbon fiber	-120~350	
柔性石墨 Flexible graphite	-200~600	
5860胶夹480D551锦纶帆布 5860 glue clamp 480 D551 nylon canvas	-40~80	

订货时应详细说明以下条件: When you place an order should detail the following conditions:

- 产品型号 The product model
- 公称直径, 公称压力 Nominal diameter, nominal pressure
- 信号压力, 弹簧范围 Signal pressure, spring range
- 流量特性, 阀前后压力 Flow characteristics, valve and pressure
- 流体介质种类 Fluid medium types

ZMA^P_N-W型气动薄膜波纹管调节阀由气动薄膜执行机构和波纹管密封的单双座阀两部分组成。其阀芯部件采用波纹管密封结构，上阀盖顶端仍有填料密封，形成两道密封，可严格防止介质向外泄漏，因此适用于调节剧毒、贵重、易挥发或易渗透的工艺介质。

ZMA^P_N-W type pneumatic film bellows valve by pneumatic diaphragm actuator and bellows seal single seat valve of two parts. The valve core components are bellows seal structure, the valve cover the top still have packing seal, forming two seal, but strictly prevent medium to external leakage, therefore suitable for regulating virulent and precious, volatile or easy penetration process medium.

主要技术参数 Main technical parameters

公称口径(mm) Nominal diameter	25	32	40	50	64	80	100
阀座直径(mm) Seat diameter	26,24	32,30	40,38	50,48	66,64	80,78	100,98
额定流量系数Kv Rated flow coefficient	10	16	25	40	63	100	160
流量特性 Characteristics	直线，等百分比 Straight line, equal percentage						
公称压力(MPa) Nominal pressure	1.0 1.6 4.0						
连接型式 Connection type	法兰连接：按JB78-59标准 Flange connection: according to JB78-59 standard						
执行机构型号 With actuator type	ZMA-2		ZMA-3		ZMA-4		
有效面积Fe(cm ²) Effective area	280		400		630		
行程L(mm) stroke	16		25		40		
作用方式 Mode of action	气关式；气开式 Gas close type; Gas open type						
弹簧压力范围(KPa) Spring pressure range	标准20~100，可选用40~200、20~60、60~100 Standard 20-100, can choose 40-200, 20-60, 60-100						
供气压力(Mpa) Gas supply pressure	标准0.14 可选用0.24 Standard 0.14 can choose 0.24						
气源接头 Air joint	M16 x 1.5						
固有可调比R Inherent Rangeability	30: 1						

主要技术性能指标 The main technical performance index

项目 project	不带阀门定位器 Don't take valve positioner	带阀门定位器 Take the valve positioner
基本误差% Basic main difference	≤ ± 5	≤ ± 1
回差% Return difference	≤ 3	≤ 1
死区% Dead zone	≤ 3	≤ 0.4
泄漏量 leakage	0.01% × 阀额定容量 0.01% × Valve rated capacity	
额定流时系数误差% Rated flow coefficient of the error	≤ 10	

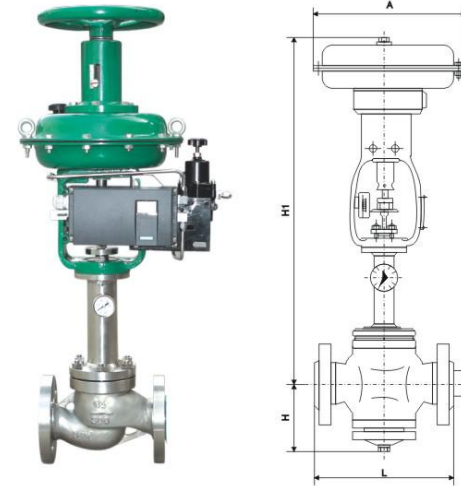

阀体材料和适用温度范围 The valve body material and suitable temperature range

阀体材料 Body material	材料牌号 Material brand	公称压力(MPa) Nominal pressure	适用温度范围(°C) Suitable temperature range
铸钢 Cast steel	ZG230-450	1.0, 1.6, 4.0	-40~150
铸不锈钢 Cast stainless steel	ZG1Cr18Ni9Ti ZG0Cr18Ni12Mo2Ti		-60~150

允许压差 Allow differential pressure

标准匹配的气动薄膜波纹管密封双座调节阀建议工作压力差不超过1MPa。为确保调节精度，必须配以阀门定位器。
Standard matched pneumatic film bellows seal two-seater regulator suggest operating differential pressure does not exceed 1 MPa. To ensure that the control precision, we must match with the valve positioner.

外形尺寸 Physical size

公称口径(mm) Nominal diameter	A	L		H		H1
		PN1.0, 1.6	PN2.5, 4.0	气关式 Gas close type	气开式 Gas open type	
25	Φ280	185	190	583	636	104
32		200	210	585	638	107
40	Φ325	220	230	716	795	126
50		250	255	721	800	131
65	Φ410	275	285	1064	1165	175
80		300	310	1081	1182	190
100		350	355	1093	1194	202

T940H-100电动给水回转式调节阀 T940H-100 electric water rotary valve

用途：安装在锅炉给水管道上或高加疏水管道上，供调节给水流量。

Use: Installed in the boiler feed water pipe or high and drain pipe road, for regulating feed water flow.

结构简述

1. 阀门主要由阀体、阀座、阀瓣、阀杆、阀盖等组成。
2. 阀门的流量调节是靠圆筒形的阀瓣相对阀座回转改变阀瓣上窗口来实现。
3. 阀门的开、关范围为60°，由阀门上方的开度指示板来指示。

Structure briefly

1. the main valve by valve body, valve seat and valve disc and stem, valve cover, etc.
2. the valve flow control is to rely on circular disc relative seat rotary change valve disc window to realize.
3. the valve open and close range for 60°, the top of the valve opening indicator board to instructions.

安装说明：阀门安装在水平管道上，须按箭头所指的介质流向安装。

Installation instructions: valve installed in a horizontal line, must according to the arrow to the flow direction of medium installation.

主要零件材料 The major parts material

件号 Piece number	1	2	3	4	5
零件名称 Part name	阀体 body	阀座 seat	阀瓣 disc	阀杆 stem	阀盖 Valve cover
材料 material	碳钢 Carbon steel	不锈钢 Stainless steel	不锈钢 Stainless steel	不锈钢 Stainless steel	碳钢 Carbon steel



产品性能 Product performance

公称压力 (MPa) Nominal pressure	公称通径 (mm) Nominal diameter	水压试验压力 (MPa) Hydraulic test pressure	给水温度 T≤(°C) Feed temperature	设计压差 ΔP (MPa) Design pressure domain	最大流通面积 fmax (cm²) Maximum circulation area	最大流量 Qmax (T/h) Maximum flow	适用介质 Medium	流量特性 Characteristics	压力特性 Pressure characteristics	泄漏量 leakage
2.5	50	3.8	170	0.4	1.89	12.1	水、油、蒸汽 Water, oil, steam	进口压力保持不变，流量从大到小变化时，出口压力的偏差值为5~10% Flow remain unchanged, the import pressure from big to small change, outlet pressure deviation value is 5~10%	流量保持不变，进口压力从大到小变化时，出口压力的偏差值为±5~10% Flow remain unchanged, the import pressure from big to small change, outlet pressure deviation value is ±5~10%	为最大流量的0.01~0.05% For maximum flow of 0.01~0.05%
	65				2.72	17.4				
	80				3.56	22.8				
	100				6.14	39.3				
	150				12.26	78.5				
4.0	50	6	170	0.5	1.89	13.6				
	65				2.72	19.5				
	80				3.56	25.5				
	100				6.14	44.0				
	150				12.26	83.3				
10	50	15		0.5	5.76	50.3				
	80				5.14	45.6				
	100				8.96	78.8				
	125				14.5	110.5				
	150				18.28	160.9				
	200				33.38	293.36				

主要外形尺寸和连接尺寸 The main dimensions and connection dimension

公称压力 (MPa) Nominal pressure	公称通径 (mm) Nominal diameter	主要外形尺寸和连接尺寸 The main dimensions and connection dimension											
		L	H	H1	D	D1	D2	D6	b	f	f1	n	d
2.5	50	230	238	165	160	125	100	不帶凹下部份 Don't take a lower concave	20	3	不帶凹下部份 Don't take a lower concave	4	φ18
	65	290	248	175	180	145	120		22	3		8	φ18
	80	310	267	190	195	160	135		22	3		8	φ18
	100	350	279	210	230	190	160		24	3		8	φ23
	150	480	338	280	300	250	218		30	3		8	φ25
4.0	50	230	238	165	160	125	100	88	20	3	4	φ18	
	65	290	248	175	180	145	120	110	22	3	4	φ18	
	80	310	267	190	195	160	135	121	22	3	4	φ18	
	100	350	279	210	230	190	160	150	24	3	4.5	φ23	
	150	480	338	280	300	250	218	204	32	3	4.5	φ25	
6.4	50	300	242	170	195	145	115	88	28	3	4	φ25	
	80	380	270	180	250	200	160	150	34	3	4.5	φ25	
	100	400	280	212	265	210	175	150	38	3	4.5	φ30	
10	125	400	330	268	310	250	210	176	42	3	4.5	φ34	
	150	450	330	268	350	290	250	204	46	3	4.5	φ34	
	200	550	380	310	430	360	315	260	54	3	4.5	φ40	

电动调节阀系列 Electric control valve series



T94₂⁰H 电动调节阀 T94₂⁰H electric control valve

主要特性及用途

电动调节阀是DKZ型电动单元组合仪表中的执行机构，它按受统一的标准信号0~10mA(D、C)，420mA(D、C)经伺服放大器放大，使电机带动减速器运行而产生轴向推力，使阀芯作相应移动，从而达到对压力、流量、温度、液位等工艺参数的调节。

电动调节阀由DKZ型执行机构和调节阀两部分组成。执行机构是推动装置，它以电源为动力，输出推力，调节阀是调节部分，直接与介质接触，调节介质的流量。

电动直通单座调节阀，具有泄漏量少的优点，但不平衡力较大，故工作压力不宜过高。电动直通双座调节阀，具有流通能力大，不平衡力小优点。

广泛应用于化工、石油、冶金、电力、轻纺等工业生产过程的自动调节中。

Main properties and USES

Electric control valve is DKZ type electric unit combination instrument of the actuator, it by unified standard signal 0-10mA(D, C) 420mA(D, C) the servo amplifier amplification, make the motor drive reducer operation and produce axial thrust, make the valve core corresponding mobile, attain thus to the pressure, flow rate, temperature, liquid level, such as the adjustment of process parameters.

Electric control by DKZ type actuator and control valve two parts. Actuator is to promote device, it with power supply for power, export thrust, control valve is control part, direct contact with the media, regulatory medium flow.

Electric through single seat regulator, has the advantages of less leakage, but unbalanced force is bigger, the work pressure difference is unfavorable and exorbitant. Electric through two-seater regulator, has the flow capacity is big, unbalanced force small advantage.

Widely used in chemical, petroleum, metallurgy, electric power, textile and other industrial production processes autopilot in.

主要技术参数

输入信号: 0~10mA 4~20mA
输入电阻: 200Ω
输入通道: 3个
电源电压: 220V
灵敏度: 150uA
非线性偏差: ≤±3.5%
正反行程偏差: ≤3%
迟滞: ≤1%
使用环境温度: 电动调节阀0~+55℃
使用环境湿度: 电动调节阀≤95%
允许泄漏量: T942H型为KV值的0.01%
T941H型为KV值的0.1%
流量能力偏差: ≤±10% (当C≤5时, ≤±15%)
流量特性偏差: ≤±10% (当C≤5时, ≤±15%)
流通能力C是当调节阀全开, 阀两端压为1kgf/cm², 通过该调节阀的以m³/h或T/h的流量数。
介质重量为1g/cm³时,
流经调节阀的以m³/h或T/h的流量数。

Main technical parameters

The input signal: 0-10mA 4-20mA
Input resistance: 200Ω
Input channel: 3
Power supply voltage: 220V
Sensitivity: 150 uA
Nonlinear deviation: ≤±3.5%
Positive and negative stroke variation: ≤3%
Dun lag: ≤1%
Use environment temperature: electric control valve 0~+55℃
Use environment humidity: electric control ≤95%
Allow leakage: T942H type for KV value of 0.01%
T941H type for KV value of 0.1%
Flow ability deviation: ≤±10% (when C≤5, ≤±15%)
Flow characteristic deviation: ≤±10% (when C≤5, ≤±15%)
Flow capacity C is when regulating valve fully open, valve for pressure on both ends 1kgf/cm², Medium severe for 1g/cm³,
Flow capacity C is when regulating valve fully open, valve for pressure on both ends 1kgf/cm², Through the control valve with m³/h or T/h make flow number.
Flow capacity C is when regulating valve fully open, valve for pressure on both ends 1kgf/cm², Through the control valve with m³/h or T/h make flow number.
Flow capacity C is when regulating valve fully open, valve for pressure on both ends 1kgf/cm², Through the control valve with m³/h or T/h make flow number.

公称口径(mm) Nominal diameter	20																							
阀座直径(mm) Seat diameter	10	12	15	20	25	32	40	50	65	80	100	125	150	200	250	300								
额定流量T942H 流量T941H (KV) Rated flow coefficient	1.2	2	3.2	5	8	12	20	32	50	80	120	200	280	450	700	1000								
流量特性 Characteristic	直线, 等百分比 Straight line, equal percentage																							
行程L(mm) stroke	10				16				25				40				80				100			
出轴推力(Kg) The axial thrust	400				400				640				1600											
配用执行机构 型号 With actuator type	(ZAZ-25) DKZ-310				DKZ-310				DKZ-410				DKZ-510											
作用方式 Mode of action	电开式(K) 电关式(B) Electric open, electric close type																							
信号(mA,DC) signal	Ⅱ 0~10mA或Ⅲ 4~20mA																							

电动调节阀的法兰标准按下述规定选用:
公称压力PN1.6, 按JB79-59铸钢法兰选定;
公称压力PN4.0, 6.4按JB79-59铸钢法兰选定。
电动调节阀通常情况下, 根据公称压力, 工作温度不同, 其阀体材料如下所述:
铸铁HT200: 公称压力1.6MPa, 工作温度-20~+200℃
铸钢ZG25: 公称压力4.0、6.4MPa, 工作温度-40~+250℃(带散热片时最高工作温度可达-40~+450℃);
铸不锈钢: ZG1Cr18Ni9Ti, 公称压力4.0、6.4 MPa, 工作温度-60~+250℃
(带散热片时最高工作温度可达-60~+450℃)
Electric control valve flange standard according to the following provisions choose:
Nominal pressure PN1.6, according to JB79-59 cast iron flanges selected;
Nominal pressure PN4.0, 6.4 regulation according to JB79-59 cast steel flange selected. Electric control valve normally, according to the nominal pressure, working temperature is different, its body material written as follows:
Cast iron HT200: nominal pressure 1.6 MPa, work temperature -20~+200℃
Cast steel ZG25: nominal pressure 4.0, 6.4 MPa, work temperature -40~+250℃ (with a little heat highest working temperature can reach -40~+450℃);
Cast stainless steel: ZG1Cr18Ni9Ti, nominal pressure 4.0, 6.4 MPa, Working temperature -60~+250℃ (with a little heat highest working temperature can reach -60~+450℃)



T94₁⁰H 电动调节阀 T94₁⁰H electric control valve

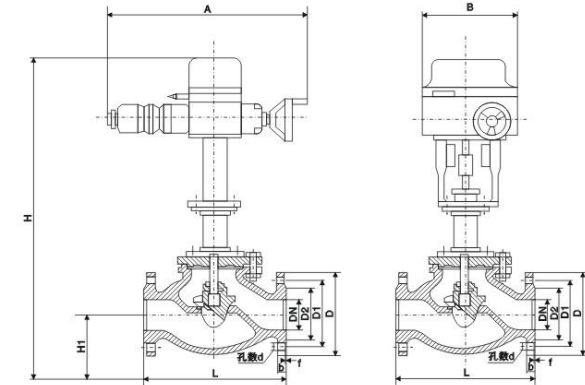

外形尺寸 Physical size

公称口径(mm) Nominal diameter	A	B	L				H				H1	
			T942H		T941H		T942H		T941H			
			普通型 ordinary	热片型 hot strip type	普通型 ordinary	热片型 hot strip type	T942H	T941H				
20	460	230	180	185	190	495	655	/	/	65	/	
25			185	190	205	767	928	878	937	112	117	
32			200	210	220	793	740	793	943	118	120	
40			220	230	240	812	963	832	982	129	139	
50			250	255	265	842	993	842	992	144	144	
65			275	285	295	967	1127	987	1147	178	188	
80			300	310	325	990	1142	1017	1177	191	208	
100			350	355	370	999	1151	1041	1207	195	220	
125			410	425	440	1092	1307	1142	1357	245	270	
150			450	460	475	1112	1327	1162	1377	255	280	
200	550	560	570	1187	1402	1244	1459	290	320			
250	640	660	670	1452	1712	1572	1832	390	440			
300	725	785	800	1558	1829	1693	1965	435	502			
400	910	1250	1100	1850	2100	1950	2100	630	680			

主要特性及用途

电动调节阀是2SB35电动单元组合仪表中的执行机构，它接受统一的标准信号0-10mA (D、C)；4-20mA(D、C)经伺服放大器放大，使电机带动减速器而产生轴推力，使阀芯作相应移动，从而达到对压力、流量、温度、液位等工艺参数的调节。
电动调节阀由执行机构和调节阀两部分组成。执行机构是推动装置，以电源为动力，输出推力，调节阀是调节部分，直接与介质接触，调节介质的流量。
电动直通单座调节阀，具有泄漏量少的优点，但不平衡力较大，故工作压力差不宜过高。电动套筒调节阀，具有流通能力大，不平衡力小优点。广泛应用于化工、石油、冶金、电力、轻纺等工业生产过程的自动调节中。

Main properties and USES

Electric control valve is 2 sb35 electric unit combination instrument of the actuator, it accept unified standard signal 0-10mA (D, C) ; 4-20mA (D, C) the servo amplifier amplification, make the motor drive reducer to move a line and produce axial thrust, make the valve core corresponding mobile, attain thus to the pressure, flow rate, temperature, liquid level, such as the adjustment of process parameters.
Electric control valve, the executing agency and regulator of two parts. Actuator is to promote device, in order to supply for power, export thrust, control valve is control part, direct contact with the media, regulatory medium flow.
Electric through single seat regulator, has the advantages of less leakage, but unbalanced force is bigger, the working pressure difference is unfavorable and exorbitant. Electric sleeve valve, has the flow capacity is big, unbalanced force small advantage. Widely used in chemical, petroleum, metallurgy, electric power, textile and other industrial production processes autopilot in.

主要技术能数

输入信号：0-10mA 4-20mA
输入电阻：200Ω
输入通道：3个
电源电压：220V 50-60Hz
灵敏度：150uA
非线性偏差：≤±3.5%
正行程偏差：≤3%
迟滞：≤1秒
使用环境温度：电动调节阀0-+55℃
使用环境湿度：电动调节阀≤95%
允许泄漏量：T947H型为KV值的0.01%
流量能力偏差：≤10% (当C≤5时，≤15%)
流量特性偏差：≤10% (当C≤5时，≤15%)
流通能力C是当调节阀全开，阀两端压差为1 kg/cm²，介质重度为1g/cm³时，流经调节阀的以M³/h或T/h计的流量数。

The main technical can number

The input signal: 0-10mA 4-20mA
Input resistance: 200Ω
Input channel: 3
Power supply voltage: 220V 50-60Hz
Sensitivity: 150uA
Nonlinear deviation: ≤±3.5%
Positive and negative stroke variation: ≤3%
Dun lag: ≤1 seconds
Use environment temperature: electric control valve 0-+55℃
Use environment humidity: electric control valve ≤ 95%
Allow leakage: T947H type for KV value of 0.01%
Flow ability deviation: ≤10% (when C≤5, ≤15%)
Flow characteristic deviation: ≤10% (when C≤5, ≤15%)
Flow capacity C is when regulating valve fully open, valve ends pressure difference is 1 kg/cm², dielectric severe for 1 g/cm³, flows through the control valve to M³/h or T/h make flow number.

主要参数、性能指标与材料 The main parameters, performance index and material

调节阀的主要参数见表一 The main regulator parameters see table 1

公称直径(mm) Nominal diameter		20	25	32	40	50	65	80	100	125	150	200
额定流量系数 Kv Rated flow coefficient	直线 Straight line	6.9	11	17.5	27.5	44	69	110	176	275	440	690
	等百分比 equal percentage	6.3	10	16	25	40	63	100	160	250	440	630
额定行程L(mm) Rated stroke		16		25			40			60		
固有流量特性 The intrinsic flow feature		直线，等百分比 Straight line, equal percentage										
公称压力(MPa) Nominal pressure		1.6 4.0 10.0										
固有可调比R Inherent Rangeability		50:1										
工作温度T(°C) Working temperature		普通型：铸铁-20-200℃，铸钢：-40-250℃，铸不锈钢：-60-250℃ 散热型：铸钢-40-450℃，铸不锈钢：-60-450℃ Common type: cast iron - 20-200 °C, cast steel: - 40-250 °C, cast stainless steel: - 60250 °C Cooling type: cast steel - 40-450 °C, cast stainless steel - 60450 °C										
压力恢复系数(FL) Pressure recovery coefficient		单座：流开0.92，流关：0.85，套筒阀：0.84 Single seat: flow open 0.92, Flow shut: 0.85, sleeve valve: 0.84										

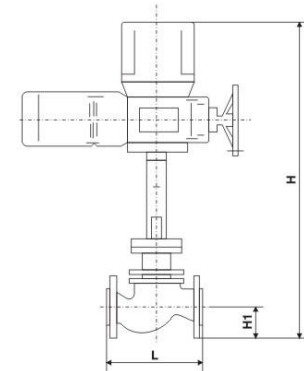

性能指标见表二 Performance index see table 2

序号 Serial number	项目 project	单座阀 Single seat valve
1	基本误差% Basic main difference	±2.5
2	回差% Return difference	2.0
3	死区% Dead zone	3.0
4	额定行程偏差(%) Rated stroke deviation	+2.5
5	允许泄漏量(1H) Allow leakage	10 ⁻⁴ × 阀额定容量 10 ⁻⁴ × Valve rated capacity
6	额定流量系数偏差(%) The rated flow coefficient deviation	±10
7	固定流量特性 Fixed flow characteristic	符合IEC534-1T和GBT4213-92中规定的斜率偏差要求 Conform to the IEC534-1T and GBT4213-92 specified in the slope deviation requirements

注：本产品性能指标贯彻GB/4213-92标准。Note: this product performance index implement GB / 4213-92 standard.

T947H型电动常温、中温型单座(套筒)调节阀外形尺寸见表三

T947H type electric room temperature, temperature type single seat (sleeve) valve overall dimensions, see table 3

DN	L			H		H1		
	PN16	PN40	PN100	普通 ordinary	高温 High temperature	PN16	PN40	PN100
20	150	185	188	686	844	57		70
40	222	235	251	719	892	75		85
50	254	267	286	733	911	82		90
65	276	292	311	852	1040	92		102
80	298	371	337	871	1064	100		107
100	352	368	394	889	1107	110	117	125
150	451	473	508	1097	1372	142	150	175
200	600		650	1137	1412	170	187	207

概述

T94⁴8H型电动调节阀外形小体轻,性能优良,是高品质的基型电动调节阀产品。它适用于一般流体介质工艺条件的生产过程控制系统。

本产品由2SB35型执行机构和精小型套筒调节阀级成。精度高,装校简便。套筒阀特点如下:

- 1、采用平衡型阀芯,不平衡力小,允许压差大,操作稳定;
- 2、阀芯导向面大,可改善由涡流和冲击引起的振荡,并减少损坏;
- 3、套筒上设有许多对称小孔,来降低压力降;
- 4、比普通单双座调节阀噪声降低10dB左右;
- 5、结构简单,装拆维修方便;

本系列产品性能好,操作稳定,能在广泛的应用中满足用户的控制需要。

overview

T94⁴8H type electric control valve form small body light, with excellent performance and it is of high quality base type electric control valve products.

It is suitable for general fluid medium process conditions of production process control system.

This product by 2 SB35 type actuator and fine small set of Jane regulator level into. High precision, simple loading school. Sleeve valve features below:

- 1.the use of balanced type valve core, unbalanced force is small, allow differential pressure big, operation stability;
- 2.valve core guide surface big, can improve the eddy current and the impact caused by the oscillation, and to reduce damage;
- 3.the sleeve has many symmetry holes, to reduce the pressure drop;
- 4.than the ordinary single seat valve noise reduction 10 dB or so;
- 5.simple structure, loading and convenient maintenance;

This series product performance is good, stable operation, can in a wide range of applications to meet the user's control need.

主要技术参数及性能指标 The main technical parameters and performance index

主要技术参数 Main technical parameters

公称通径(mm) Nominal diameter	25	40	50	65	80	100	150	200	250	300
额定流量系数 K _v Rated flow coefficient	直线 Straight line	6.9	17.6	27.5	44	69	110	176	275	440
	等百分比 equal percentage	6.3	16	25	40	63	100	160	250	400
允许压差MPa Allow differential pressure		6.4				4.2	4.6	3.7	2.7	2.2
控制信号 Control signal	4~20mA d.c., 1~5V d.c.									
电源 power	220V a.c. 50Hz									
公称压力(MPa) Nominal pressure	1.6、4.0、6.4									
工作温度℃ Working temperature	铸钢: -40~250, -40~450 铸不锈钢: -40~250, -60~450 Cast steel: -40~250, -40~450 Cast steel: -40~250, -60~450									
固有流量特性 The intrinsic flow feature	直线、等百分比(固有可调比50:1) Straight line, equal percentage (inherent Rangeability)									

主要技术性能指标(套筒阀) The main technical performance index (sleeve valve)

基本误差: ±1.0%	Basic error: plus or minus 1.0%
回差: 1.0%	Return difference: 1.0%
死区: 1.0%	Dead zone: 1.0%
泄漏量: 5×10 ⁻³ 阀额定容量	Leakage: 5×10 ⁻³ valve rated capacity
额定流量系数: ±10%	The rated flow coefficient: ±10%
固有流量特性: 斜率±30%	The intrinsic flow feature: slope plus ±30%

主要零件材料

阀体、阀盖: ZG230-450, ZG1Cr18Ni9Ti, ZG0Cr18Ni12Mo2Ti, 或相当的美国牌号WCB, CF8套筒单座CF8M

阀芯: 1Cr18Ni9Ti 0Cr18Ni12Mo2Ti, 或相当的美国牌号304, 316(特殊材料或堆焊史太立合金可商洽)

填料: 聚四氟乙烯, 柔性石墨

The major parts material

Body and bonnet: ZG230-450, ZG1Cr18Ni9Ti, ZG0Cr18Ni12Mo2Ti, or rather of American brand WCB, CF8 sleeve single-seat CF8M

Valve core: 1Cr18Ni9Ti 0Cr18Ni12Mo2Ti, or rather of American brand 304, 316 (special materials or overlaying history too made alloy can discuss with)

Packing: teflon, flexible graphite

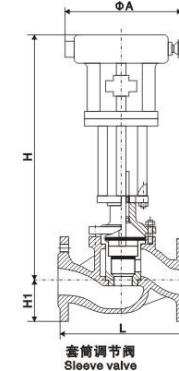

外形尺寸和重量 Physical size and weight

DN	L			H		H1			ΦA	PN16 PN40 PN64	
	PN16	PN40	PN64	普通 ordinary	高温 High temperature	PN16	PN40	PN64		PN16	PN40 PN64
25	184	197	210	503	653	57	70	70	260	15	19
40	222	235	251	648	813	75	85	85	260	26	35
50	254	267	286	650	820	82	90	90	290	30	40
65	276	292	311	752	932	92	102	102	290	34	53
80	298	317	337	764	949	100	107	107	290	42	65
100	352	368	394	782	992	110	117	125	360	52	86
150	451	473	508	1077	1337	142	150	172	360	152	206
200	600	650	650	1097	1357	170	187	207	360	220	280
250	730	775	775	1240	1560	202	225	235	360	423	470
300	850	900	900	1271	1591	230	257	265	360	663	735

连接型式

法兰连接: FF, RF, RJ, LG, 沟槽型, 嵌入式
法兰标准: JISB2201-1984, ANSIB 16.5-1981, JB79-59
焊接连接: 对接焊SW, 对焊BW

Connection type

Flange connection: FF, RF, RJ, LG, groove type, embedded type
Flange standards: JISB2201-1984, ANSIB 16.5-1981, JB79-59
Welding connection: scarf welding SW, butt welding BW

产品型号 Product model

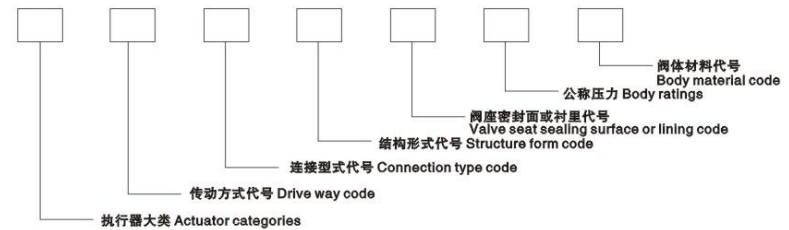

特性及用途

智能型电动调节阀由PSL智能型直行程电动执行机构，它直接接受4-20mA/4-12mA/12-22mA/0-5V/1-5V等控制信号，输出隔离4-20mA两位反馈信号，具有自诊断功能，使电机带动减速器，运行而产生轴向推力，阀芯作相应移动，从而达到对压力、流量、温度、液位等工艺参数的调节，便可轻松满足您高性能电动调节阀的需求，可以广泛地适用于电力、石油、化工、冶金、医药、轻工、建材、锅炉等行业。

Characteristics and USES

Intelligent electric control valve by intelligent PSL straight stroke electric actuators, it directly accept 4-20 mA/4-12 mA/12-22 mA/0-5 V/1-5 V, the control signal, the output isolation 4-20 mA valve position feedback signal, have self diagnosis function, make motor drive reducer, operation and produce axial thrust, valve core corresponding mobile, attain thus to the pressure, flow rate, temperature, liquid level, as well as the technical parameters of the regulation, can easily meet you for high-performance electric control valve needs, can be widely used in electric power, petroleum, chemical industry, metallurgy, medicine, light industry, building materials, boiler, etc.

技术参数

输入信号: 4-mA 4-12mA 12-20mA 1-5V
输入电阻: 200Ω
电源电压: 220V 50-60Hz
灵敏度: 150uA
非线性偏差: ≤±3.5%
正行程偏差: ≤3%
迟滞: ≤1%
使用环境温度: 电动调节阀 0~+55℃
使用环境湿度: 电动调节阀 ≤95%
允许泄漏量: QSLP型为KV值的0.01% QSLM型为KV值的0.1%
流量能力偏差: ≤±10% (当Cv≤5时, ≤±15%)
流量特性偏差: ≤±10% (当Cv≤5时, ≤±15%)

Technical parameters

The input signal: 4-mA 4-12mA 12-20mA 1-5V
Input resistance: 200Ω
Power supply voltage: 220V 50-60Hz
Sensitivity: 150uA
Nonlinear deviation: ≤±3.5%
Positive and negative stroke deviation: ≤3%
Dun lag: ≤1%
Use environment temperature: electric control valve 0~+55℃
Use environment humidity: Electric control valve ≤95%
Allow leakage: QSLP type for KV value of 0.01% QSLM type for KV value of 0.1%
Flow ability deviation: ≤±10% (when Cv ≤5, ≤±15%)
Flow characteristic deviation: ≤±10% (when Cv ≤5, ≤±15%)

流通能力Cv是当调节阀全开，阀两端压差为1kgf/cm²，介质重度为1g/cm³时，流经调节阀的以m³/T/h计的流量数。

Flow capacity Cv is when the valve fully open, valve ends pressure difference is 1 kgf/cm², medium severe for 1 g/cm³, through the control valve to m³ or T/h make flow number.

公称直径(mm) Nominal diameter	20																							
阀座直径(mm) Seat diameter	10	12	15	20	25	32	40	50	65	80	100	125	150	200	250	300	350	400						
额定流量 系数Kv Rated flow coefficient	QSLP	1.2	2	3.2	5	8	12	20	32	50	80	120	200	280	450	700	1000	1450	1900					
	QSLM	—				10	16	25	40	63	100	160	250	400	630	1000	1600	2200	2800					
流量特性 Characteristics	直线，等百分比 Straight line, equal percentage																							
行程(mm) stroke	10				16				25				40				60				100			
出轴推力(N) The axial thrust	2000				4000				8000				16000				20000							
执行机构型号 actuator type	PSL-202				PSL-204				PSL-208				PSL-316											
作用方式 Mode of action	电开式(K) 电关式(B) Electric open type electric close type																							
信号(mA.DC) signal	4-20mA 4-12mA 12-20mA 0-5V 1-5V																							

电动调节阀的法兰标准按下述规定选用:

公称压力PN1.6、按JB78-59铸钢法兰选定;

公称压力为PN4.0、6.4按JB79-59铸钢法兰选定。

电动调节阀通常情况下，根据公称压力，工作温度不同，其阀体材料如下所述:

铸钢HT200:公称压力1.6MPa, 工作温度-20~+200℃;

铸钢Z325:公称压力4.0、6.4MPa工作温度-40~+250℃(带散热片时

最高工作温度可达-40~+450℃)

铸不锈钢: ZG1Cr18Ni9Ti, 公称压力4.0、6.4MPa, 工作温度-60-

+250℃(带散热片时最高工作温度可达-60+450℃)

Electric control valve flange standard according to the following provisions chooses:

Nominal pressure PN1.6, according to JB78-59 cast iron flanges selected;

Nominal pressure for PN4.0, 6.4 according to JB79-59 cast steel flange selected.

Electric control valve normally, according to the nominal pressure, working temperature is different, its body material written as follows:

Cast iron HT200: nominal pressure 1.6 MPa, work temperature -20 ~ +200 °C;

(with a little heat highest working temperature can reach -40 ~ +450 °C)

Cast stainless steel: ZG1Cr18Ni9Ti, nominal pressure 4.0, 6.4 MPa, work temperature

-60 ~ +250 °C (with a little heat highest working temperature can reach -60 +450 °C)

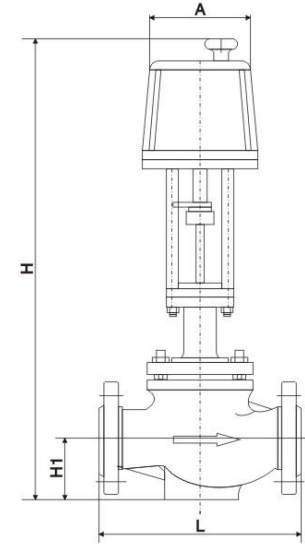

公称直径(mm) Nominal diameter	A	L			H				H1	
		PN1.6	PN4.0	PN6.4	QSLP		QSLM		QSLP	QSLM
					普通型 ordinary	热片型 hot strip type	普通型 ordinary	热片型 hot strip type		
20	260	180	185	190	653	804	/	/	65	/
25		184	197	210	665	816	670	820	112	117
32		200	210	220	671	822	673	823	118	120
40		222	235	251	683	834	693	843	129	139
50		254	267	286	698	849	698	848	144	144
65	310	276	292	311	789	949	799	959	178	188
80		298	317	337	792	952	809	969	191	208
100		352	368	394	796	956	821	981	195	220
125		410	425	440	847	1062	872	1067	245	270
150		451	473	508	855	1070	882	1098	255	280
200	350	600	612	650	894	1109	924	1139	290	320
250		650	670	690			1156	1368	380	440
300		740	770	800			1215	1427	435	502
350		850	860	870			1420	1635	465	580
400		920	950	970						

概述

ZRQM系列智能型电动调节阀是一种压力平衡式调节阀。配有2SA8系列智能型电动执行机构，总体结构紧凑、重量轻、稳定性好、防护等级高。因而广泛应用于大型火电厂、化工厂、水处理厂和污水处理、天然气油田、钢铁厂等自动调节系统中。

Overview

ZRQM series intelligent electric control valve is a kind of pressure balance type valve. With 2SA8 series intelligent electric actuators, overall structure compact, light weight, good stability, high protection grade. Therefore widely used in large thermal power plants, chemical plants, water treatment plant and sewage treatment, natural gas field, steel mills automatic control system.

主要零件材料

阀体、阀盖: ZG230-450、ZG1Cr18Ni9Ti
阀芯、阀座: 1Cr18Ni9Ti, 司钛莱合金堆焊
阀杆、推杆: 2Cr13, 1Cr18Ni9Ti
衬套: 2Cr13
填料: 聚四氟乙烯、柔性石墨、不锈钢波纹管

The major parts material

Body and bonnet: ZG230-450, ZG1Cr18Ni9Ti
Valve core and valve seat: 1Cr18Ni9Ti, company lai titanium alloy surfacing
Valve lever, push rod: 2Cr13, 1Cr18Ni9Ti
Bush: 2Cr13
Packing: teflon, flexible graphite, stainless steel bellows

主要技术参数

电动执行机构主要技术参数
输出推力: 44-550KN
(输出调节推力: 5.17-47.05KN)
(输出额定关闭推力: 8.4-63.15KN)
位置控制基本误差: (设定行程时间 \geq 25秒) \pm 1%
重复性误差: (设定行程时间 \geq 25秒) \leq 1%
死区: 0.1%-9.9%可调
输出额定负载下启动频率: 1200次/小时
输入信号: 420mA/100 Ω , 2-10mA/100 Ω , DC24V开关量。
供电电源: 380 \pm 10%VAC, 50Hz
相对湿度: \leq 95%
环境温度: -30 $^{\circ}$ C~+70 $^{\circ}$ C
防爆等级: Exd II B14
防护等级: IP68
输入输出通道均采用光电隔离

Main technical parameters

Electric actuators main technical parameters
Output thrust: 44 - 550 KN
(output regulation thrust: 5.17 - 47.05 KN)
(output rated closing thrust: 8.4 - 63.15 KN)
Position control basic error: (set travel time was 25 seconds) \pm 1%
Repeatability error: (set travel time was 25 seconds) 1% or less
Dead zone: 0.1% - 9.9% adjustable
Output rated load startup frequency: 1200 time/hour
The input signal: 420mA/100 Ω , 2-10mA/100 Ω , DC24V switch quantity.
Power supply: 380 \pm 10% VAC, 50 Hz
Relative humidity: 95% or less
The environment temperature: -30 $^{\circ}$ C~+70 $^{\circ}$ C
Explosion-proof level: Exd II B14
Protection level: IP68
Input/output channel adopts photoelectric isolation

调节阀主要技术参数 Regulatory agency main technical parameters

公称直径(mm) Nominal diameter (阀芯直径) Seat diameter	25	32	40	50	65	80	100	125	150	200	250	300	350	400	450	500
额定流量系数Kv Rated flow coefficient	直线 Straight line		11	17.6	27.5	44	69	110	176	275	440	690	1100	1760		
	等百分比 equal percentage		10	16	25	40	63	100	160	250	400	630	1000	1600		
额定行程L(mm) Rated stroke	16		25		40			60			100					
固有流量特性 The intrinsic flow feature	直线, 等百分比 Straight line, equal percentage															
固有可调比R Inherent Rangesability	50:1															
允许泄漏量 Allow leakage	硬密封: IV级、软密封: VI级 Hard seal: level IV, soft seal: VI level															
公称压力(MPa) Nominal pressure	1.6、4.0、6.4															
工作温度T ($^{\circ}$ C) Working temperature	常温型 Cold type		-20-200、-40-250、-60-250													
	散热型 Cooling type		-40-450、-60-450													
	高温型 Type high temperature		450-560													
	低温型 Low temperature type		-60~-100、-100~-200、-200~-250													

*本产品性能指标贯彻GB/T4213-92。*This product performance Index Implement GB/T4213-92.

阀体形式 Body form

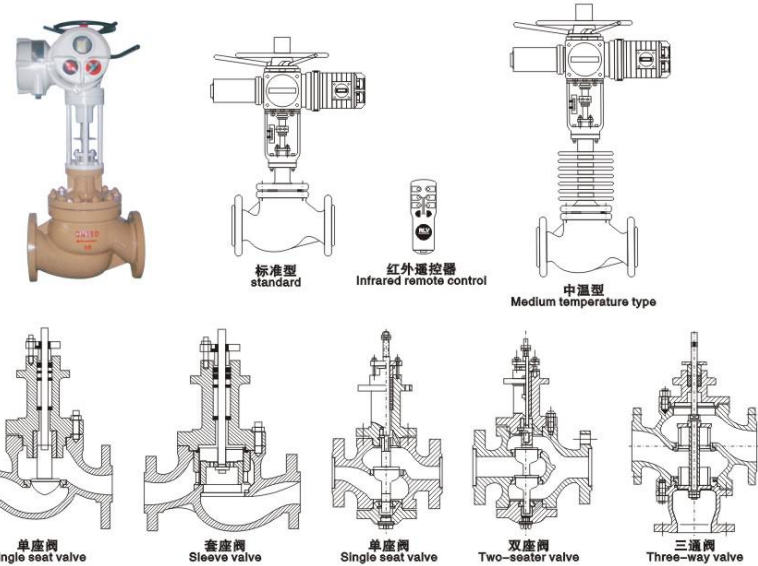

主要功能及特点 The main function and characteristics

- 双密封结构 Double seal structure
- 非侵入式设计思想 Noninvasive design thought
- 转矩保护 Torque protection
- 自动相序调整 Automatic phase sequence adjustment
- 瞬时反转保护 Instantaneous reversal protection
- 电源缺相保护 Power phase lack protection
- 阀门卡住时保护 Valve locks protect
- 过热保护 Overheating protection
- 阀位和转矩的检测 Valve position and torque detection
- 固态继电器和惯性制动功能 Solid state relay and inertia brake function
- 间隙定时操作 Clearance timing operation
- 现场总线控制 Field bus control
- 执行机构的显示功能 Actuator display function
- 执行机构的调试和故障查找 Actuator commissioning and troubleshooting
- 电子门锁功能 Electronic latch function
- 红外设定功能(可设定以下内容) Infrared setting function (can be set the following content)
 - A. 关闭时输出轴的转动方向 A. closed output shaft rotation direction
 - B. 打开限位和关闭限位的保护选择 B. open limit and closed limit protection choice
 - C. 打开和关闭操作的转矩设定值 C. Open and close operation torque value
 - D. 就地控制选择点动或是保持 D. local control option or keep moving
 - E. 四个状态指示继电器的触发选择 E. Four status indication relay trigger choice
 - F. 紧急动作功能选择 F. emergency action option
 - G. 远控禁动功能选择 G. remote control the dynamic option
 - H. 模拟控制信号的设定 H. analog control signal set



ZAZP型电动直通单座调节阀 ZAZP type electric through single seat valve

概述

ZAZP系列电动直通单座调节阀由DKZ型系列直行程电动执行机构和直通单座阀两部分组成，以单相交流220V电源为动力，接受0-10mA或4-20mA直流信号，自动地控制调节阀开度，达到对管道内流体的压力、流量、液位等工艺参数的连续调节。

该产品具有动作灵敏、能源取用方便、信号传输迅速等特点。广泛应用于电力、冶金、化工、轻纺等工业自动控制系统中。产品符合JB/T7387-1994。

overview

ZAZP series of electric through single seat valve by DKZ type series straight stroke electric actuators and through single seat valve of two parts, with single-phase ac 220 v power supply for power, accept 0-10 mA or 4-20 mA Dc signal, automatically control valve opening, the pipeline fluid pressure, flow, liquid level, as well as the technical parameters of continuous adjustment.

This product has the kilt, energy take with convenient, signal transmission characteristics of rapidly. Widely used in electric power, metallurgy, chemical industry, textile and other industrial automatic control system.

Product complies with JB/T7387-1994.

主要技术参数和性能指标 The main technical parameters and performance index

产品型号 Product model

产品型号 Product model	ZAZP-16型	ZAZP-40型	ZAZP-64型 ZAZP-64G型	ZAZP-100型 ZAZP-100G型
	-	-		

主要技术参数 Main technical parameters

公称直径(mm) Nominal diameter	G3/4"								20		25	32	40	50	65	80	100	125	150	200
阀座直径(mm) Seat diameter	3	4	5	6	7	8	10	12	15	20	26	32	40	50	66	80	100	125	150	200
额定流量系数Kv Rated flow coefficient	0.08	0.12	0.2	0.32	0.5	0.8	1.2	2	3.2	5	8	12	20	32	50	80	120	200	280	450
流量特性 Characteristics	直线 Straight line								直线，等百分比 Straight line, equal percentage											
公称压力(MPa) Nominal pressure	10								1.6、4.0、6.4											
连接型式 Connection type	管螺纹连接G3/4 Pipe thread connection								法兰连接: PN1.6按JB79-59标准; PN4.0、6.4按JB79-59标准 Flange connection: PN1.6 regulation according to JB79-59 standards PN4.0, 6.4 regulation according to JB79-59 standard											
配用执行机构型号 With actuator type	ZAZ-25				DKZ-310				DKZ-310				DKZ-410				DKZ-410			
出抽推力(N) The smoke thrust	250				4000				4000				6400				6400			
行程L(mm) stroke	10										16		25		40		60			
全行程时间(s) Full travel time	20				20				8		12.5		20		32		37			
作用方式 Mode of action	电开式(K)常用; 电关式(B) Electric open (K) commonly used; Electric close type (B)																			
输入信号 Input signal	0-10mA 4-20mA DC																			
供电电源 Power supply	220V;50-60Hz																			
固有可调比R Inherent Rangeability	30:1																			

执行机构主要技术参数 Actuator main technical parameters

项目 project	技术性指标 Technical performance index
基本误差% Basic main difference	≤ ± 5
回差% Return difference	≤ 3
死区% Dead zone	≤ 5
泄漏量 leakage	0.01% × 阀额定容量 0.01% × Valve rated capacity
额定流量系数误差% Rated flow coefficient of the error	≤ ± 10; 当Kv ≤ 6.3时, 为 ≤ ± 15

ZAZP型电动直通单座调节阀 ZAZP type electric through single seat valve

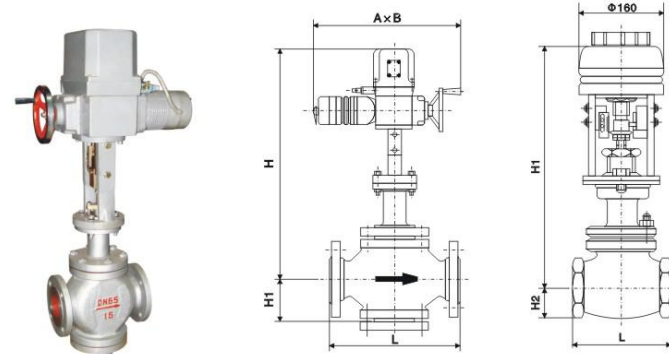

阀门材料和适用温度范围 The valve material and suitable temperature range

阀体材料 Body material	材料牌号 Material brand	公称压力(MPa) Nominal pressure	适用温度范围(°C) Suitable temperature range	
			常温型 Cold type	热片型 hot strip type
铸铁 Cast iron	HT200	1.6	-20-200	-
铸钢 Cast steel	ZG230-450	4.0、6.4	-40-250	-40-450
铸不锈钢 Cast stainless steel	ZG1Cr18Ni9Ti ZG0Cr18Ni12Mo2Ti	4.0、6.4	-40-250	-60-450

允许压差 Allow differential pressure

公称直径(mm) Nominal diameter	G3/4"								20					
	3	4	5	6	7	8	10	12	15	20				
允许压差(MPa) Allow differential pressure	公称压力值 Nominal pressure value								4.9	3.7	2.4	1.6	1.1	0.6
公称直径(mm) Nominal diameter	25	32	40	50	65	80	100	125	150	200				
允许压差(MPa) Allow differential pressure	PN值	5.0	2.8	1.7	1.7	1.0	0.6	1.1	0.7	0.4				

注: 4配DKZ-310其允许压差可达公称压力值 Note: 4 match DKZ-310 it allows pressure general of nominal pressure value

外形尺寸 Physical size

公称直径(mm) Nominal diameter	A x B	L			H1		H2
		PN1.6	PN4.0	PN6.4	常温型 Cold type	热片型 hot strip type	
G3/4"	φ 160						32
20	230 x 460	180	190	190	653	804	65
25		185	190	200	665	816	99
32		200	210	210	671	822	105
40		220	230	235	683	834	116
50	230 x 530	250	255	265	698	849	131
65		275	285	295	789	949	165
80		300	310	320	792	852	173
100		350	355	370	796	956	177
125	260 x 630	410	425	440	847	1062	225
150		450	460	475	855	1070	233
150		450	460	475	855	1070	233
200		550	560	570	894	1109	272



ZAZN型电动直通双座调节阀 ZAZN type electric through two-seater regulator

概述

ZAZN系列电动直通双座调节阀由DKZ型系列直行程电动执行机构和直通双座阀两部分组成。以单相交流220V电源为动力，接受0~10mA或4~20mA直流信号，自动地控制调节阀开度，达到对管道内流体的压力、流量、液位等工艺参数的连续调节。
该产品具有动作灵敏、能源取用方便、信号传输速等特点。广泛应用于电力、冶金、化工、轻纺等工业自动控制系统中。
产品符合JB/T7387-1994。

overview

series straight stroke electric actuators and through two-seater valve of two parts, with single-phase ac 220V power supply for power, accept 0 ~ 10 mA or 4 ~ 20 mA Dc signal, automatically control valve opening, the pipeline fluid pressure, flow, liquid level, as well as the technical parameters of continuous adjustment.

This product has the kill, energy take with convenient, signal transmission speed etc. Widely used in electric power, metallurgy, chemical industry, textile and other industrial automatic control system.
Product complies with JB/T7387-1994.

主要技术参数和性能指标 The main technical parameters and performance index

产品型号 Product model

产品型号 Product model	ZAZN-16型	ZAZN-40型	ZAZN-64型	ZAZN-64G型
-----------------------	----------	----------	----------	-----------

主要技术参数 Main technical parameters

公称通径(mm) Nominal diameter	25	32	40	50	65	80	100	125	150	200	250	300
阀座直径(mm) Seat diameter	26, 24	32, 30	40, 38	50, 48	66, 64	80, 78	100, 98	125, 123	150, 148	200, 197	252, 248	303, 297
额定流量系数Kv Rated flow coefficient	10	16	25	40	63	100	160	250	400	630	1000	1600
流量特性 Characteristics	直线，等百分比 Straight line, equal percentage											
公称压力(MPa) Nominal pressure	1.6, 4.0, 6.4											4.0, 6.4
连接型式 Connection type	法兰连接: PN1.6 JB79-59标准; PN4.0, 6.4按JB79-59标准 Flange connection: PN1.6 JB79-59 standards; PN4.0, 6.4 regulation according to JB79-59 standard											
执行机构型号 With actuator type	DKZ-310			DKZ-410			DKZ-410			DKZ-510		
出抽推力(N) The smoke thrust	4000			6400			6400			16000		
行程L(mm) stroke	16		25		40		60		100			
全行程时间(s) Full travel time	12.5		20		32		37		62			
作用方式 Mode of action	电开式(K)常用; 电关式(B) Electric open (K) commonly used; Electric close type (B)											
输入信号 Input signal	0~10mA 4~20mA DC											
供电电源 Power supply	220V; 50~60Hz											
固有可调比R Inherent Rangesability	30:1											

主要技术性能指标 The main technical performance index

项目 project	技术性能指标 Technical performance index
基本误差% Basic main difference	≤ ± 5
回差% Return difference	≤ 3
死区% Dead zone	≤ 5
泄漏量 leakage	0.01% × 阀额定容量 0.01% × Valve rated capacity
额定流量系数误差% Rated flow coefficient of the error	≤ ± 10

ZAZN型电动直通双座调节阀 ZAZN type electric through two-seater regulator

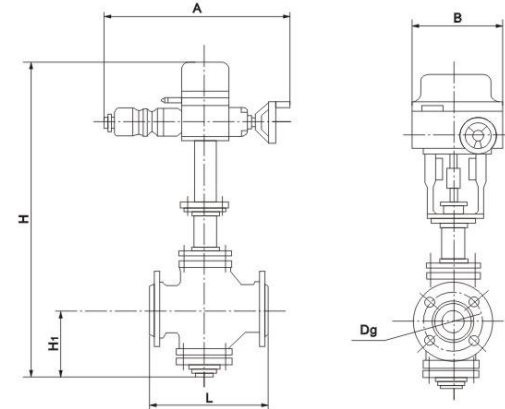

阀门材料和适用温度范围 The valve material and suitable temperature range

阀体材料 Body material	材料牌号 Material brand	公称压力(MPa) Nominal pressure	适用温度范围(°C) Suitable temperature range	
			常温型 Cold type	热片型 hot strip type
铸铁 Cast iron	HT200	1.6	-20~200	-
铸钢 Cast steel	ZG230-450	4.0, 6.4	-40~250	-40~450
铸不锈钢 Cast stainless steel	ZG1Cr18Ni9Ti ZG0Cr18Ni12Mo2Ti	4.0, 6.4	-40~250	-60~450

允许压差

标准组配的电动双座调节阀考虑到介质对阀芯、阀座的冲蚀和高压差引起的噪声、振动，一般情况下，阀的压差不应超过1MPa，如压差较高，则应采取相应的工艺措施。

Allow differential pressure

Standard matched electric two-seater regulator considering media on the valve core and valve seat of erosion and high pressure differential caused by noise, vibration, in the ordinary circumstances, valve pressure difference should not exceed 1 MPa, such as differential pressure is higher, it should adopt the corresponding process measures.

公称通径(mm) Nominal diameter	A	B	L			H				H1	
						ZAZP		ZAZN			
			PN1.6	PN4.0	PN6.4	普通型 ordinary	热片型 hot strip type	普通型 ordinary	热片型 hot strip type	ZAZP	ZAZN
20	460	230	180	185	190	495	655	/	/	65	/
25			185	190	205	767	928	787	937	112	117
32			200	210	220	793	940	793	943	118	120
40			220	230	240	812	963	832	982	129	139
50			250	255	265	842	993	842	992	144	144
65			275	285	295	967	1127	987	1147	178	188
80			300	310	325	990	1142	1017	1177	191	208
100			350	355	370	999	1151	1041	1207	195	220
125			410	425	440	1082	1307	1142	1357	245	270
150			450	460	475	1112	1327	1162	1377	255	280
200	550	560	570	1187	1402	1244	1459	290	320		
250	640	660	670	1452	1712	1572	1832	380	440		
300	630	260	720	740	770	1558	1829	1693	1965	435	502
350			800	850	900	1265	1487	1265	1487	546	546
400			1100	1150	1200	1850	2100	1950	2100	630	680

概述

ZAZM电动套筒调节阀由DKZ型系列直行程电动执行机构和套筒阀两部分组成，以单相交流220V电源为动力，接受0-10mA或4-20mA直流信号，自动地控制调节阀开度，从而达到对压力、温度、流量、液位等工艺参数的连续调节。
该产品具有比双座阀更大的流量系数，且允许压差大，稳定性好，工作时不易产生振动，适用性强等优点，广泛地应用于电力、冶金、石油、化工、轻工等工业部门的自动控制系统。
产品符合JB/T7387-1994。

overview

ZAZM electric sleeve valve by DKZ type series straight stroke electric actuators and sleeve valve of two parts, with single-phase ac 220V power supply for power, accept 0-10mA or 4-20mA Dc signal, automatically control valve opening, attain thus to the pressure, temperature, flow, liquid level, as well as the technical parameters of continuous adjustment.

The product has more than two seater valve flow coefficient, and allow differential pressure big, good stability, work not easy to generate vibration, wide applicability etc, widely used in electric power, metallurgy, petroleum, chemical industry, light industry and other industrial departments of the automatic control system.

Product complies with JB/T7387-1994.

主要技术参数和性能指标 The main technical parameters and performance index

产品型号 Product model

产品型号 Product model	ZAZM-16型	ZAZM-40型	ZAZM-64型
-----------------------	----------	----------	----------

主要技术参数 Main technical parameters

公称直径(mm) Nominal diameter								
额定流量系数Kv Rated flow coefficient	全量 Full quantity	15	35	50	125	190	400	630
	0.6	9	20	30	75	115	240	350
流量特性 Characteristics	直线，等百分比 Straight line, equal percentage							
公称压力(MPa) Nominal pressure	1.6, 4.0, 6.4							
连接型式 Connection type	法兰连接: PN1.6JB79-59标准 Flange connection: PN1.6 JB79-59 standards							
配用执行机构型号 With actuator type	DKZ-310		DKZ-410		DKZ-410			
出抽推力(N) The smoke thrust	4000		6400		6400			
行程L(mm) stroke	16	25	40		60			
全行程时间(s) Full travel time	12.5	20	32		37			
作用方式 Mode of action	电开式(K)常用; 电关式(B) Electric open (K) commonly used; Electric close type (B)							
输入信号 Input signal	0-10mA 4-20mA DC							
供电电源 Power supply	220V; 50-60Hz							
固有可调比R Inherent Rangesibility	30:1							

主要技术性能指标 The main technical performance index

项目 project	技术性能指标 Technical performance index
基本误差% Basic main difference	≤ ± 5
回差% Return difference	≤ 3
死区% Dead zone	≤ 5
泄漏量 leakage	0.01% × 阀额定容量 0.01% × Valve rated capacity
额定流量系数误差% Rated flow coefficient of the error	≤ ± 10

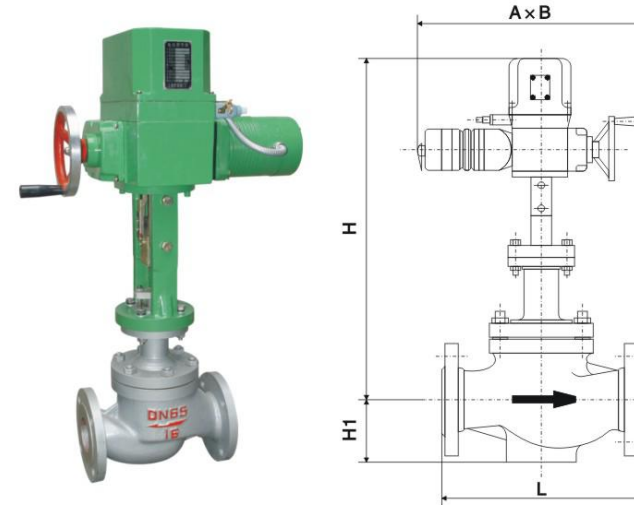

阀门材料和适用温度范围 The valve material and suitable temperature range

阀体材料 Body material	材料牌号 Material brand	公称压力(MPa) Nominal pressure	适用温度范围(°C) Suitable temperature range	
			常温型 Cold type	热片型 hot strip type
铸钢 Cast steel	ZG230-450	4.0, 6.4	-40-250	-40-450
铸不锈钢 Cast stainless steel	ZG1Cr18Ni9Ti ZG0Cr18Ni12Mo2Ti	4.0, 6.4	-40-250	-60-450

允许压差

标准组配的电动双座调节阀考虑到介质对阀芯、阀座的冲蚀和高压差引起的噪声、振动，一般情况下，阀的压差不应超过1MPa，如压差较高，则应采取相应的工艺措施。

Allow differential pressure

Standard matched electric two-seater regulator considering media on the valve core and valve seat of erosion and high pressure differential caused by noise, vibration, in the ordinary circumstances, valve pressure difference should not exceed 1 MPa, such as differential pressure is higher, it should adopt the corresponding process measures.

外形尺寸 Physical size

公称直径(mm) Nominal diameter	A × B	L			H		H ₁
		PN1.6	PN4.0	PN6.4	常温型 Cold type	热片型 hot strip type	
25	230 × 460	184	197	210	668	819	75
40		222	235	251	684	835	95
50		254	267	286	684	835	98
80		298	317	337	785	946	130
100	230 × 530	352	368	394	795	946	156
150		451	473	508	945	1160	208
200		600	620	650	945	1160	250
250		650	670	690	1050	1320	265
300	260 × 630	740	770	800	1145	1380	295



ZAZ_X型电动三通合流(分流)调节阀 ZAZ_X type electric tee junction (split) regulating valve

概述

ZAZ(X)型电动三通合流(分流)调节阀有合流和分流两种型式,由DKZ电动执行机构和三通合流或三通分流调节阀组成。以电源为动力,接受统一的标准信号0~10mA DC或4~20mA DC驱动阀门开度与此操作信号相对应。合流阀的作用是将两种流体汇成第三种流体,分流阀是将一种流体分成两路流体。分流合流阀只能对应选用,但当DN≤80时,合流阀可用于分流场合。可替代两台单、双座调节阀,节省投资,占据空间小。三通调节阀通常用于热交换器的两种介质调节,及简单的配比调节。
产品符合JB/T7387-1994。

overview

ZAZ(X) type electric tee junction (split) valve have interflow and shunt two type, by DKZ electric actuators and tee junction or tee diverter valve composition. To power as a driving force, accept unified standard signal 0 ~ 10 mA DC or 4 ~ 20 mA DC drive valve opening and the corresponding operation signal. Confluence valve is the role of two kinds of fluid merge the third kind of fluid, diverter valve is a kind of fluid into two road fluid. Shunt confluence valve can only corresponding to choose, but when DN≤80, confluence valve can be used for shunt occasion. Alternative two single, double seat regulator, the save on investment, occupy the space is little. Three-way valve is usually used for heat transfer converter of the two kinds of media regulation, and simple ratio regulation.

Product complies with JB/T7387-1994.

主要技术参数和性能指标 The main technical parameters and performance index

产品型号 Product model

公称直径(mm) Nominal diameter	合流 Interflow		25	32	40	50	65	80	100	125	150	200	250	300	
	分流 shunt							80	100	125	150	200	250	300	
额定流量系数Kv Rated flow coefficient	合流 Interflow		8.5	13	21	34	52	85	135	210	340	535	800	1260	
	分流 shunt							85	135	210	340	535	800	1260	
公称压力(MPa) Nominal pressure		1.6, 4.0, 6.4													
流量特性 Characteristics		直线 Straight line													
执行机构 Actuator	II型 II type		DKZ-310		DKZ-310		DKZ-410			DKZ-410			DKZ-510		
	III型 III type		DKZ-310C		DKZ-310C		DKZ-410C			DKZ-410C			DKZ-510C		
	出轴推力(N) The axial thrust		4000		4000		6400			6400			16000		
	行程L(mm) stroke		16		25		40			60			100		
允许压差(MPa) Allow differential pressure		1.6	1.0	2.5	1.6	1.5	1.0	0.65	0.4	0.3	0.16	0.26	0.18		
上阀盖型式 On valve cover type		普通式(常温型) 热片式(中温型) Common type (cold type) hot plate (medium temperature type)													
介质温度℃ Medium temperature		-20~+200, -40~+250(常温型)、-40~+450(中温型) -20~+200, -40~+250(cold type)、-40~+450(medium temperature type)													
可调比R Rangeability		30: 1													
法兰标准 Flange standards		按JB79-59													
输入阻抗 Input impedance		II型: 200Ω III型: 250Ω													
出厂状态 Factory state		电开(对上阀座而言),如需电关,订货时应注明 Electric drive (against the seat terms), such as the need to electric shut, when you place an order should be marked													

主要技术性能指标 The main technical performance index

项目 project	技术性能指标 Technical performance index
基本误差% Basic main difference	±3.5
回差% Return difference	≤2.5
死区% Dead zone	≤3.0
始点偏差% Always point deviation 电开、电关 Electric drive, electric shut	±2.5
额定行程偏差% Rated stroke deviation	±2.5
允许泄漏量L/h Allow leakage	≤1×10 ⁻⁸ ×阀额定容量 < 1×10 ⁻⁸ ×Valve rated capacity

P075

www.tjybfm.com

ZAZ_X型电动三通合流(分流)调节阀 ZAZ_X type electric tee junction (split) regulating valve



外形尺寸 Physical size

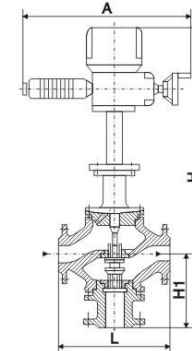

三通合流调节阀
Tee junction regulator

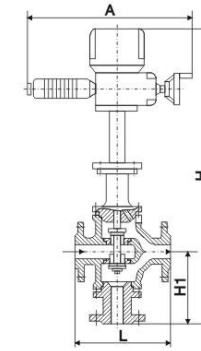

三通分流调节阀
Tee diverter valve

公称直径 (mm) Nominal diameter			L			H				H ₁						
	分流 shunt	合流 interflow	PN			分流 shunt		合流 interflow		PN						
			PN	PN	PN	普通型 ordinary	热片型 hot strip type	普通型 ordinary	热片型 hot strip type	PN	PN	PN				
25	520	490	185	190	200	普通型 ordinary	热片型 hot strip type	普通型 ordinary	热片型 hot strip type	1.6	4.0	6.4	1.6	4.0	6.4	
32	520	490	200	210	210			715	865					140	150	160
40	520	490	220	230	235			721	871					150	160	170
50	520	490	250	255	265			733	883					160	170	180
65	520	490	275	285	295			748	898					180	190	200
80	520	520	300	310	320	872	1032	842	1002	225	250	265	210	230	240	
100	520	520	350	355	370	896	1056	846	1006	245	275	285	220	250	260	
125	520	520	410	425	440	947	1162	897	1112	285	320	325	260	300	300	
150	520	520	450	460	475	947	1162	897	1112	305	340	340	280	320	320	
200	520	520	550	560	570	965	1180	905	1120	350	400	410	320	380	380	
250	520	520	640	660	670											
300	520	520	740	760	770											

订货须知

订货时请填写《规格书》或详细注明以下内容:

- 1、产品型号 2、公称直径 3、公称压力 4、使用介质 5、输入信号 6、流量系数 7、阀体材质 8、附件

Order instructions

When ordering, please fill in 《specification》 or specify the following contents:

- 1.product model 2.nominal diameter 3.nominal pressure 4.use medium 5.the input signal 6.flow coefficient 7.body material 8.accessories

www.tjybfm.com

P076

ZAZS型电动角形调节阀由DKZ-II型DKZ系列直行程电动执行机构和角形阀两部分组成。以单相交流220V电源为动力，接受0-10mA或4-20mA直流信号，自动控制调节阀开度，从而达到对压力、温度、流量、液位等工艺参数的连续调节。

角形阀是直角式单导向结构，其流路简单阻力小，泄漏量小，适用于高粘度、含有悬浮和颗粒状介质流体的调节，可以避免堵塞、粘堵、堵塞等现象，有一定的自净能力，也便于清洗。广泛地应用于电力、冶金、石油、化工、轻工、食品等工业部门的自动控制系统中。

ZAZS type electric Angle regulator by DKZ-II type DKZ series straight stroke electric actuators and Angle valve of two parts. With single-phase ac 220 v power supply for power, accept 0-10 mA or 4-20 mA Dc signal, automatically control valve opening, attain thus to the pressure, temperature, flow, liquid level, as well as the technical parameters of continuous adjustment.

Angle valves are rectangular type single guide structure, its flow simple small resistance and leakage quantity is small, be applicable to the high viscosity, contains suspended and granular dielectric fluid regulation, can avoid coking, bonding and plugging wait for a phenomenon, has certain self-purification ability, also facilitate cleaning. Widely used in electric power, metallurgy, petroleum, chemical industry, light industry, food and other departments of industry automatic control system.

产品型号 Product model

产品型号 Product model	ZAZS-64型	ZAZS-64G型
--------------------	----------	-----------

主要技术参数 Main technical parameters

公称通径(mm) Nominal diameter	20												25	32	40	50	65	80	100	125	150	200
阀座直径(mm) Seat diameter	10	12	15	20	26	32	40	50	66	80	100	125	150	200								
额定流量系数Kv Rated flow coefficient	1.6	2.5	4.0	6.3	10	16	25	40	63	100	160	250	400	630								
流量特性 Characteristics	直线，等百分比 Straight line, equal percentage																					
公称压力(MPa) Nominal pressure	6.4																					
连接型式 Connection type	法兰连接：PN6.4按JB79-59标准 Flange connection: PN6.4 regulation according to JB79-59 standard																					
配用执行机构型号 With actuator type	ZAZ-25		DKZ-310		DKZ-310				DKZ-410				DKZ-510									
出抽推力(N) The smoke thrust	250		4000		4000				6400				16000									
行程L(mm) stroke					16		25		40				60									
全行程时间(s) Full travel time	20		8		12.5		20		32				37									
作用方式 Mode of action	电开式(K常用); 电关式(B) Electric open (K commonly used); Electric close type (B)																					
供电电源 Power supply	220V;50-60Hz																					
输入信号 Input signal	0-10mA 4-20mA DC																					
固有可调比R Inherent Rangeability	30:1																					

主要技术性能指标 The main technical performance index

项目 project	技术性能指标 Technical performance index
基本误差% Basic main difference	≤ ± 5
回差% Return difference	≤ 3
死区% Dead zone	≤ 5
泄漏量 leakage	0.01% × 阀额定容量 0.01% × Valve rated capacity
额定流量系数误差% Rated flow coefficient of the error	≤ ± 10; 当Kv ≤ 6.3时, 为 ≤ ± 15

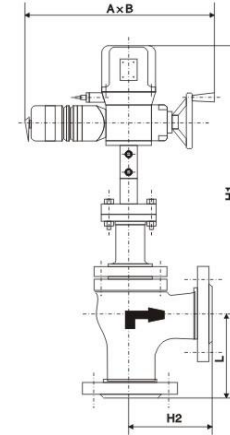

阀门材料和适用温度范围 The valve material and suitable temperature range

阀体材料 Body material	材料牌号 Material brand	公称压力(MPa) Nominal pressure	适用温度范围(°C) Suitable temperature range	
			常温型 Cold type	热片型 hot strip type
铸钢 Cast steel	ZG230-450	6.4	-40~250	-40~450
铸不锈钢 Cast stainless steel	ZG1Cr18Ni9Ti ZG0Cr18Ni12Mo2Ti	6.4	-40~250	-60~450

允许压差 Allow differential pressure

公称通径(mm) Nominal diameter	20												25	32	40	50	65	80	100	125	150	200
阀座直径(mm) Seat diameter	10	12	15	20	26	32	40	50	66	80	100	125	150	200								
允许压差(MPa) Allow differential pressure	2.4	1.6	1.1	0.6	6.4	3.7	2.4	1.5	1.4	1.0	0.6	1.0	0.7	0.4								

注：DN20配DK2-310，其允许压差可达6.4MPa Note: with 3/4"DK2-310, it allows pressure general 6.4 MPa

外形尺寸 Physical size

公称通径(mm) Nominal diameter	A x B	L	H2	H1	
				常温型 Cold type	热片型 hot strip type
20	320 x 460	100	100	638	793
25		115	115	645	796
32		130	130	647	798
40		130	130	660	811
50		150	150	668	819
65	230 x 530	170	170	754	915
80		190	190	756	917
100		215	215	776	937
125		250	250	887	1102
150	260 x 630	275	275	902	1117
200		325	327	934	1149



ZDLP型电子式电动单座调节阀
ZDLP type electronic electric single seat valve

概述

ZDLP型电子式电动单座调节阀是由3810L系列电子式电动执行机构和单座调节机构组成。电动执行机构内有伺服系统，无须另配伺服放大器，有输入信号及电源即可控制运转，连线简单，调节机构阀芯采用顶导向，适用于对泄漏量要求严格，阀前后压差低及有一定粘度和含有纤维介质的场合。

产品符合JB/T7387-1994。

Overview

ZDLP type electronic electric single seat valve is made of 3810L series electronic electric actuators and single seat adjusting mechanism composition. Electric actuator has servo system, without the other match servo amplifier, input signal and power can control operation, the attachment is simple, adjusting mechanism valve core using top guide, suitable for leakage requirements strictly, valve and low differential pressure and have certain viscosity and contain fiber medium occasions. Product complies with JB/T7387-1994.

主要技术参数和性能指标 The main technical parameters and performance index

主要技术参数 Main technical parameters

公称直径(mm) Nominal diameter	G3/4"				20				25	32	40	50	65	80	100	125	150	200				
阀座直径(mm) Seat diameter	3	4	5	6	7	8	10	12	15	20	26	32	40	50	65	80	100	125	150	200		
额定流量系数Kv Rated flow coefficient	0.08	0.12	0.2	0.32	0.5	0.8	1.2	2	3.2	5	8	16	25	40	63	100	160	250	400	630		
公称压力(MPa) Nominal pressure	1.6, 4.0, 6.4(常温)、4.0, 6.4(中温)、0.6, 4.0, 6.4(低温) 1.6, 4.0, 6.4 (room temperature), 4.0, and 6.4 (temperature), 0.6, 4.0, and 6.4 (low temperature)																					
行程L(mm) stroke	10				16				25				40				60					
动作速度mm/s Movement speed	4.2				2.1				3.5				1.7				3.4					
流量特性 Characteristics	直线, 等百分比 Straight line, equal percentage																					
介质温度℃ Medium temperature	-20~+200、-40~250(常温)、-20~+450(中温)、-250~+60(低温) -20 + 200, 40 - 250 (room temperature), -20 + 450 (temperature), -250 - 60 (low temperature) -																					
法兰尺寸 Flange size	铸钢法兰按JB79-59 Cast steel flange regulation according to JB79-59																					
连接型式 Connection type	法兰密封面型式按JB77-59, 铸铁法兰按光滑式, 铸钢法兰按凹式, 低温按槽式 Flange sealing surface pattern according to JB77-59, cast iron flange according to smooth type, cast steel flange by concave type, low temperature by tenon groove																					
阀体材质 Body material	公称压力(MPa) Rated pressure	0.6		低温-250~+60℃、ZG1Cr18Ni9Ti、CF8M Low temperature-250~+60℃、ZG1Cr18Ni9Ti、CF8M																		
		1.6		常温-20~200℃、HT200 cold-20-200℃、HT200																		
		4.0	常温-20~200℃、WCB、ZG1Cr18Ni9Ti cold-20-200℃、WCB、ZG1Cr18Ni9Ti				中温-20~450℃、WCB、ZG1Cr18Ni9Ti temperature-20-450℃、WCB、ZG1Cr18Ni9Ti															
			低温-250~+60℃、ZG1Cr18Ni9Ti(-196℃)、CF8M(-250℃) Low temperature-250~+60℃、ZG1Cr18Ni9Ti(-196℃)、CF8M(-250℃)																			
			常温-20~200℃、WCB、ZG1Cr18Ni9Ti cold-20-200℃、WCB、ZG1Cr18Ni9Ti				中温-20~450℃、WCB、ZG1Cr18Ni9Ti temperature-20-450℃、WCB、ZG1Cr18Ni9Ti															
		6.4		低温-250~+60℃、ZG1Cr18Ni9Ti(-196℃)、CF8M(-250℃) Low temperature-250~+60℃、ZG1Cr18Ni9Ti(-196℃)、CF8M(-250℃)																		
阀芯材质 Valve core material	1Cr18Ni9、F316(0Cr18Ni12Mo2)																					
上阀盖型式 On valve cover type	普通式(常温)、热片式(中温)、长颈式(低温) Common type (room temperature), hot plate (temperature), long neck type (low temperature)																					
配电动执行机构型号 With electric actuators model	381LSA-08				381LSA-20				381LSB-30				381LSB-50				381LSC-65					
	381LSA-08				381LSA-20				381LSB-30				381LSB-50									

注: 可为用户提供ANSI、JPI、JIS等国外法兰标准的产品, 结构长度按用户需要确定。
Note: can provide users with ANSI, JPI, JIS and other foreign flange standard products, according to user needs to determine the length of structure.

ZDLP型电子式电动单座调节阀
ZDLP type electronic electric single seat valve



执行机构主要技术参数 Actuator main technical parameters

型号 Type	额定输出力N Rated output force	速度mm/s speed	技术参数 Technical parameters
381LSA-08 381LXA-08	800	4.2	电源: AC220V 50Hz 输入信号: DC4-20mA DC1-5V (信号线用屏蔽线) 输出开度信号: DC4-20mA 上盖防护等级: 相当IP55 防爆标志: Exd II BT4 Power supply: AC220V 50 hz The input signal: DC4 - 20 ma DC1 - 5 v (signal wire with shielded wire) Output opening signal: DC4 - 20 ma Cover protection level: quite IP55 Explosion-proof mark: Exd II BT4
381LSA-20 381LXA-20	2000	2.1	
381LSB-30 381LXB-30	3000	3.5	
381LSB-50 381LXB-50	5000	1.7	
381LSC-65	6500	2.8	

性能指标 Performance index

项目 project	技术性能指标 Technical performance index		
基本误差% Basic main difference	±2.5		
回差% Return difference	2.5		
死区% Dead zone	1.0		
始/终点偏差% Always point deviation	气开 Gas open	始点 Initial point	±2.5
	气关 Gas shut	始点 Initial point	±2.5
		终点 end	±2.5
	额定流系数误差% Rated flow coefficient of the error		2.5
允许泄漏量L/h Allow leakage		≤1 × 10 ⁻⁴ 阀的额定容量 Valve rated capacity	

允许压差 Allow differential pressure

公称直径 (mm) Nominal diameter	G3/4"				20				25	32	40	50	65	80	100	125	150	200		
阀座直径 (mm) Seat diameter	3	4	5	6	7	8	10	12	15	20	26	32	40	50	66	80	100	125	150	200
允许压差 (mm) Allow differential pressure	公称压力(MPa) Nominal pressure										3.0	2.0	1.8	1.05	1.16	0.67	0.47	0.39	0.26	0.16

外形尺寸 Physical size

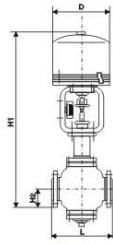

常温型
Cold type

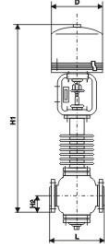

中温型
Medium temperature type

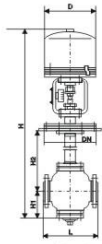

低温型
Low temperature type

ZDLP电动常、中温单座阀外形尺寸表 ZDLP electric often, medium temperature single seat valve shape dimension table

公称直径(mm) Nominal diameter	L			H ₁	H			D	重量kg weight		
	PN(MPa)				常温 cold	中温 Medium temperature	PN1.6 MPa		PN4.0, 6.4MPa		
	1.6	4.0	6.4						常温 cold	中温 Medium temperature	
G3/4"	180	75	75	30	467	504	225	12	14		
20	180	180	190	50	587	697	225	25	28		
25	185	190	200	115	556	698	225	24	28		
32	200	210	220	120	562	713	225	26	29		
40	222	235	251	130	609	760	225	36	45		
50	254	267	285	145	624	775	225	39	49		
65	276	292	311	180	791	954	225	57	76		
80	298	317	337	195	796	959	225	72	95		
100	352	368	394	200	800	963	310	85	109		
125	410	425	440	245	1042	1254	310	150	175		
150	451	473	508	255	1052	1264	310	187	231		
200	600	620	650	295	1087	1299	310	242	365		

ZDLP电动低温单座阀外形尺寸表 ZDLP electric low temperature single seat valve shape dimension table

公称直径(mm) Nominal diameter	D	DN	H ₁	-101℃		-196℃		-253℃		重量kg weight
				H ₂	H	H ₂	H	H ₂	H	
				G3/4"	225	135	30	500	1002	
20	225	250(275)	50	500	1004.5	700	1204.5	900	1404.5	36
25	225	270(290)	97	500	1005	700	1205	900	1405	40
32	225	300(310)	103	500	1011	700	1211	900	1411	43
40	255	310(340)	117	600	1053	800	1253	1000	1453	61
50	255	340(370)	132	600	1068	800	1268	1000	1468	66
65	255	380(410)	161	600	1282	800	1482	1000	1682	98
80	255	410(500)	171	600	1286	800	1486	1000	1686	110
100	255	470(590)	175	700	1280	800	1480	1000	1680	140
125	310	550(640)	230	700	1562	900	1762	1100	1962	225
150	310	600(760)	240	700	1562	900	1762	1100	1962	291
200	310	720(760)	275	700	1557	900	1757	1100	1957	461

注：括号内数字为PN64尺寸。Note: figures in brackets for PN64 size.

订货须知

订货时请填写《规格书》或注明以下内容：

- 1.产品型号
- 2.公称直径
- 3.DN G3/4"和DN20mm两种规格需注明阀座直径或者注明额定流量系数Kv
- 4.流量特性
- 5.阀体材质
- 6.低温需注明使用温度或注明接管长度
- 7.阀前背压力
- 8.介质种类和温度范围
- 9.电动执行器内是否带空间加热器
- 10.电动执行器内是否带过载保护装置
- 11.是否有其它特殊要求

Order instructions

When ordering, please fill in 《specification》 or indicate the following contents:

1. The product model
2. Nominal diameter
3. DN G3/4" and DN20mm two specifications need to indicate the valve seat diameter or indicate the rated flow coefficient Kv
4. Flow characteristic
5. Body material
6. Cryogenic valve should mark out using temperature or indicate over length
7. Valve and pressure
8. Medium types and temperature range
9. Electric actuators whether or not to bring a space heater in electric actuators with overload protection device is within
11. Are there any special requirements

概述

ZDLN型电子式电动双座调节阀是3810L型电子式电动执行机构和直通双座阀组成，电动执行机构内配有伺服系统，无须另配伺服放大器，输入220V(AC)电源及4~20mA(DC)信号，即可控制阀门开度，从而达到对介质的压力、温度、流量、液位等工艺参数的连续调节。该产品具有动作灵敏、能源取用方便、信号传输迅速，同时具有不平衡力小，允许压差大，流量系数大等特点，广泛应用于电力、冶金、化工、轻纺等行业的自动控制系统。

产品符合JB/T7387-1994。

Overview

ZDLN type electronic electric two-seater regulator is 3810L electronic electric actuators and through two-seater valve components, electric actuators with servo system in, without the other match servo amplifier, input 220 V (AC) power supply and 4~20 mA (DC) signal, can control valve opening, attain thus to the medium pressure, temperature, flow, liquid level, as well as the technical parameters of continuous adjustment.

This product has the kilt, energy take with convenient, signal transmission quickly, and at the same time has unbalanced force is small, allow differential pressure big, big flow coefficient and other characteristics, widely used in electric power, metallurgy, Chemical industry, textile industry, such as automatic control system.

Product complies with JB/T7387-1994.

主要技术参数和性能指标 The main technical parameters and performance index

双座调节阀主要技术参数 Two-seater regulatory agency main technical parameters

公称直径(mm) Nominal diameter	25	32	40	50	65	80	100	125	150	200	250	300
额定流量系数Kv Rated flow coefficient	10	16	25	40	63	100	160	250	400	630	1000	1600
公称压力(MPa) Nominal pressure	1.6、4.0、6.4 (常温) 、4.0、6.4 (中温) 、0.6、4.0、6.4 (低温) 1.6、4.0、6.4 (cold) 、4.0、6.4 (Medium temperature) 、0.6、4.0、6.4 (Low temperature)											
行程L(mm) stroke	16		25			40			60			100
动作速度mm/s Movement speed	2.1		3.5			1.7			2.8			2.0
配用电动执行机构型号 With electric actuators model	381LSA-20 381LXA-20		381LSB-30 381LXB-30			381LSB-50 381LXB-50			381LSC-65			381LSC-99
流量特性 Characteristics	直线，等百分比 Straight line, equal percentage											
介质温度℃ Medium temperature	-20~+200 (常温) 、-20~+450 (中温) 、-250~-60 (低温) -20~+200 (room temperature) 、-20~+450 (temperature) 、-250~-60 (low temperature) -											
法兰尺寸 Flange size	铸钢法兰按JB78-59 铸钢法兰按JB79-59 Cast iron flange according to JB78-59 cast steel flange regulation according to JB79-59											
法兰型式 Flange type	按JB77-59, 铸钢法兰按光滑式, 铸钢法兰按凹式, 低温按槽槽式 According to the JB77-59, cast iron flange according to smooth type, cast steel flange by concave type, low temperature by tenon grooves											
公称压力(MPa) Nominal pressure	0.6	低温-250~-80℃、ZG1Cr18Ni9Ti (-196℃) 、CF8M (-250℃) Low temperature -250~-80℃, ZG1Cr18Ni9Ti (-196℃) 、CF8M (-250℃)										
	1.6	常温-20~-200℃、WCB、CF8、CF8M cold -20~-200℃, WCB, CF8, CF8M										
	4.0	常温-20~-200℃、WCB、ZG1Cr18Ni9Ti cold -20~-200℃, WCB, ZG1Cr18Ni9Ti										
	6.4	中温-4~-450℃、WCB、ZG1Cr18Ni9Ti、CF8、CF8M Medium temperature -4~-450℃, WCB, ZG1Cr18Ni9Ti, CF8, CF8M										
公称压力(MPa) Nominal pressure	0.6	低温-250~-80℃、ZG1Cr18Ni9Ti (-196℃) 、CF8M (-250℃) Low temperature -250~-80℃, ZG1Cr18Ni9Ti (-196℃) 、CF8M (-250℃)										

执行机构主要技术参数 Actuator main technical parameters

型号 Type	额定输出力N Rated output force	速度mm/s speed	技术参数 Technical parameters
381LSA-20 381LXA-20	2000	2.1	电源: AC220V 50Hz 输入信号: DC4~20mA DC1~5V (信号线用屏蔽线) 输出开度信号: DC4~20mA 上盖防护等级: 相当IP55 防爆标志: Exd II BT4 Power supply: AC220V 50 hz The input signal: DC4 ~ 20 ma DC1 ~ 5 v (signal wire with shielded wire) Output opening signal: DC4 ~ 20 ma Cover protection level: quite IP55 Explosion-proof mark: Exd II BT4
381LSB-30 381LXB-30	3000	3.5	
381LSB-50 381LXB-50	5000	1.7	
381LSC-65	6500	2.8	
381LSC-99	10000	2.0	

性能指标 Performance index

项目 project		技术性能指标 Technical performance index	
基本误差% Basic main difference		±2.5	
回差% Return difference		2.5	
死区% Dead zone		1.0	
始/终点偏差% Always point deviation	气开 Gas open	始点 Initial point	±2.5
		终点 end	±2.5
	气关 Gas shut	始点 Initial point	±2.5
		终点 end	±2.5
额定流时系数误差% Rated flow coefficient of the error		2.5	
允许泄漏量L/h Allow leakage		≤1 × 10 ⁻⁴ 阀的额定容量 ≤1 × 10 ⁻⁴ Valve rated capacity	

允许压差 Allow differential pressure

公称直径 (mm) Nominal diameter	25	32	40	50	65	80	100	125	150	200	250	300
允许压差 (mm) Allow differential pressure											4.0	3.4
											公称压力(MPa) Nominal pressure	

外形尺寸 Physical size

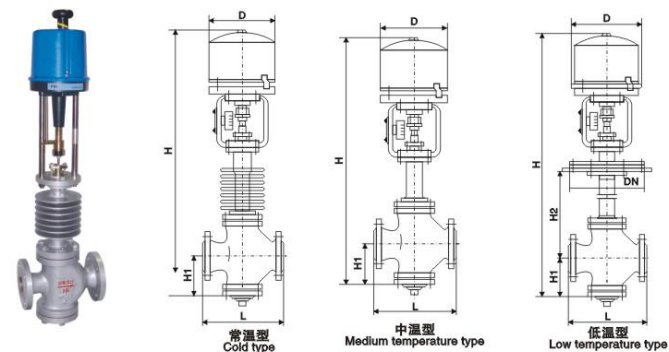

ZDLN电动常、中温双座阀外形尺寸表 ZDLN electric often, medium temperature two-seater valve shape dimension table

公称直径(mm) Nominal diameter	L			H ₁	H		D	重量kg weight		
	PN(MPa)				常温 cold	中温 Medium temperature		PN1.6 MPa	PN4.0,6.4MPa	
	1.6	4.0	6.4						常温 cold	中温 Medium temperature
25	185	190	200	120	560	710	225	26	30	33
32	200	210	210	120	563	714	225	28	31	34
40	220	230	235	140	618	769	255	38	47	51
50	250	255	265	145	623	774	255	41	51	55
65	275	285	295	190	799	962	255	61	80	88
80	300	310	320	210	812	975	255	77	100	110
100	350	355	370	220	824	987	255	96	120	131
125	410	425	440	270	1066	1278	310	160	195	244
150	450	460	475	280	1078	1290	310	205	249	269
200	550	560	570	320	1116	1328	310	275	402	435
250	640	660	670	450	1257	1497	310	485	605	665
300	720	740	770	465	1302	1543	310	635	755	825
350	800	850	900	546	1265	1487	310			
400	1100	1150	1200	680	1950	2100	310			

订货须知

订货时请填写《规格书》或注明以下内容:

- 1.产品型号
- 2.公称直径
- 3.额定流量系数Kv
- 4.流量特性
- 5.阀体材质
- 6.低温阀需注明使用温度或注明接管长度
- 7.阀前后压力
- 8.介质种类和温度范围
- 9.电动执行器内是否带空间加热器

Order instructions

When ordering, please fill in (specification) or indicate the following contents:

1. The product model
2. Nominal diameter
3. The rated flow coefficient Kv
4. Flow characteristic
5. Body material
6. Cryogenic valve should mark out using temperature or indicate over length
7. Valve and pressure
8. Medium types and temperature range
9. Electric actuators in whether or not to bring a space heater

概述

ZDLQ、ZDLX型电子式电动三通调节阀是由3810L系列电子式电动执行机构与三通调节机构组成。电动执行机构内有伺服系统，无需另配伺服放大器，有输入信号及电源可控制运转，连线简单。调节机构有合流和分流两种作用方式，在某些场合可以替代两个三通阀和一个三通接管而得到广泛应用。常用于热交换器的两相调节及简单的配比调节。

产品符合JB/T7387-1994。

overview

ZDLQ、ZDLX type electronic electric 3-way regulating valve is made of 3810 L series electronic electric actuators and tee adjusting mechanism composition. Electric actuator has servo system, without the other match servo amplifier, input signal and power control operation, and simple connections. Adjusting mechanism have interflow and shunt two ways, in some occasions can replace two two-way valve and a tee over and widely used. Often used in heat exchanger of two phase regulation and simple ratio regulation.

Product complies with JB/T7387-1994.

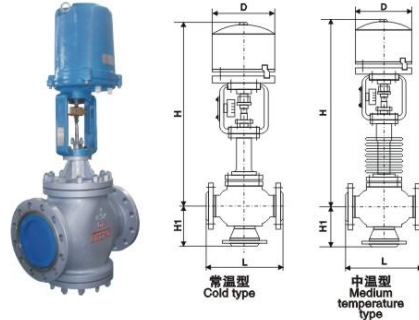

主要技术参数和性能指标 The main technical parameters and performance index
调节机构主要技术参数 Regulatory agency main technical parameters

公称直径(mm) Nominal diameter	合流 interflow	25	32	40	50	65	80	100	125	150	200	250	300	
	分流 shunt						80	100	125	150	200	250	300	
阀座直径(mm) Seat diameter		26	32	40	50	66	80	100	125	150	200	250	300	
额定流量系数Kv Rated flow coefficient	合流 interflow	8.5	13	21	34	53	85	135	210	340	535	800	1260	
	分流 shunt	8.5	13	21	34	53	85	135	210	340	535	800	1260	
公称压力(MPa) Nominal pressure		1.6, 4.0, 6.4												
行程L(mm) stroke		16		25			40			60			100	
配用电动执行机构型号 With electric actuators model		381LSA-20 381LXA-20		381LSB-30 381LXB-30		381LSB-50 381LXB-50			381LSC-65			381LSC-99		
流量特性 Characteristics		直线 Straight line												
可调比R Rangeability		30: 1												
法兰尺寸 Flange size		铸钢法兰按JB78-59，铸钢法兰按JB79-59 Cast iron flange according to JB78-59, cast steel flange regulation according to JB79-59												
法兰型式 Flange type		法兰密封面型式按JB77-59 Flange sealing surface pattern according to JB77-59												
阀体材质 Body material		WCB(ZG230-450) ZG1Cr18Ni9Ti												

执行机构主要技术参数 Actuator main technical parameters

型号 Type	额定输出力N Rated output force	速度mm/sec speed	技术参数 Technical parameters
381LSA-08	800	4.2	电源: AC220V 50Hz 输入信号: DC4-20mA DC1-5V (信号线用屏蔽线) 输出开度信号: DC4-20mA 上盖防护等级: 相当IP55 防爆标志: Exd II 8T4 Power supply: AC220V 50 hz The input signal: DC4-20 ma DC1-5v (signal wire with shielded wire) Output opening signal: DC4-20 ma Cover protection level: quite IP55 Explosion-proof mark: Exd II 8T4
381LSA-20	2000	2.1	
381LSB-30	3000	3.5	
381LSB-50	5000	1.7	
381LSC-65	6500	2.8	
381LSC-99	10000	2.0	
381LXA-08	800	4.2	
381LXA-20	2000	2.1	
381LXB-30	3000	3.5	
381LXB-50	5000	1.7	

性能指标 Performance index

项目 project	技术性能指标 Technical performance index		
基本误差% Basic main difference	±2.5		
回差% Return difference	2.5		
死区% Dead zone	1.0		
始/终偏差% Always point deviation	电开 Electric open	始点 Initial point	±2.5
		终点 end	±2.5
	电关 Electric shut	始点 Initial point	±2.5
		终点 end	±2.5
额定流时系数误差% Rated flow coefficient of the error	2.5		
允许泄漏量L/h Allow leakage	1 × 10 ⁻³ × 阀的额定容量 Valve rated capacity		

允许压差 Allow differential pressure

公称直径(mm) Nominal diameter	25	32	40	50	65	80	100	125	150	200	250	300
允许压差(mm) Allow differential pressure	0.32	2.20	2.20	1.41	1.38	0.94	0.61	0.51	0.36	0.20	0.19	0.13

外形尺寸 Physical size

三通合流调节阀外形尺寸表 Tee junction regulator outline dimension table

公称直径(mm) Nominal diameter	L PN(MPa)			行程 stroke	D	H PN(MPa)			H	
	1.6	4.0	6.4			PN(MPa)			常温 cold	中温 Medium temperature
						1.6	4.0	6.4		
25	185	190	200	16	225	145	150	160	555	707
32	200	210	210	16	225	150	160	170	561	709
40	220	230	235	25	255	160	170	180	660	812
50	250	255	265	25	255	180	190	200	675	829
65	275	285	295	40	255	210	220	220	863	1027
80	300	310	320	40	255	220	230	240	868	1032
100	350	355	370	40	255	245	250	260	872	1036
125	410	425	440	60	255	295	300	300	905	1120
150	450	460	475	60	255	310	320	320	920	1135
200	550	560	570	60	255	370	380	380	950	1165
250	640	660	670	100	415	465	474	474	1203	1440
300	740	760	770	100	415	580	585	585	1265	1502

三通分流调节阀外形尺寸表 Tee diverter valve shape dimension table

公称直径 (mm) Nominal diameter	L PN(MPa)			行程 stroke	D	H PN(MPa)			重量kg weight PN(MPa)		
	1.6	4.0	6.4			PN(MPa)			4.0	6.4	
						1.6	4.0	6.4			
80	300	310	320	40	255	240	250	260	885	78	98
100	350	355	370	40	255	265	275	285	897	93	118
125	410	425	440	60	255	310	320	320	931	155.5	172.5
150	450	460	475	60	255	330	340	340	945	207.5	323.5
200	550	560	570	60	255	390	400	400	979	384.5	412.5
250	640	660	670	100	415	530	540	540	1268	627	659
300	740	760	770	100	415	605	612	612	1294	780	819

注: 括号内数字为PN64尺寸。 Note: figures in brackets for PN64 size.

订货须知

订货时请填写《规格书》或注明以下内容:

- 1.产品型号
- 2.公称直径
- 3.阀体材质
- 4.阀前后压力
- 5.介质种类和温度范围
- 6.电动执行器内是否带空间加热器
- 7.电动执行器是否带地载保护装置
- 8.是否有其他特殊要求

Order instructions

When ordering, please fill in 《specification》 or indicate the following contents:

1. The product model
2. Nominal diameter
3. Body material
4. Valve and pressure
5. Medium types and temperature range
6. Electric actuators in whether or not to bring a space heater
7. Electric actuators with whether to load protection
8. If there is any other special requirement

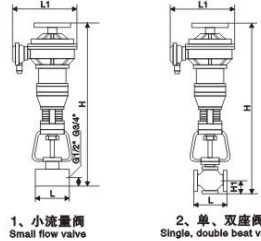

3、法兰尺寸：小流量单座、双座阀
管螺纹G1/2"、G3/4"。
公称压力 PN16采用铸铁法兰。
公称压力 PN40、64采用铸钢法兰。
3, flange size: small flow valve single, double beat valve
Pipe thread G1/2", G3/4".
Nominal pressure PN16 mining have cast iron flanges.
Nominal pressure PN40, 64 the cast steel flange.

概述

该系列调节阀的上阀盖采用长颈接管结构，则为低温调节阀，适用于低温状态下工作。调节阀的上阀盖采用波纹管结构，则为波纹管调节阀，适用于有毒、易挥发及稀有贵金属介质的调节，可以避免介质外漏引起的环境污染，影响工人健康和防止爆炸等事故，也适用于真空场合。

Overview

This series valve on the valve cover the long neck over structure, it is low temperature regulator, is suitable for low temperature state work. Regulating valve on the valve cover the corrugated tube structure, it is bellows valve, it is suitable for very poison, volatile and rare and precious metal medium regulation, can avoid medium leakage cause environmental pollution, affects the workers health and prevent explosion wait for an accident, also applies to vacuum occasion.

主要特点

- 1、单、双座阀因阀体流路复杂，不适用于高粘度、悬浮液、含固体颗粒等易沉淀、易堵塞场合。
- 2、小流量阀适用于较小流量的调节；体积小、重量轻，安装维护方便。
- 3、小流量阀、单座阀泄漏量小、允许压差小。
- 4、与小流量阀、单座阀相比，双座阀泄漏量较大，允许压差较大。

The main features

1. single, double beat valve for body flow complex, does not apply to high viscosity, suspension, containing solid particles, easy precipitation, easy blockage occasion.
2. small flow valve suitable for smaller flow regulation; Small volume, light weight, easy installation and maintenance.
3. small flow valve, single seat valve leakage, and allow small pressure difference is small.
4. with small flow valve, single seat valve, compared to two seater valve leakage is bigger, allow large pressure difference.

主要技术指标

1、阀体

型式：单座、双座为直通铸造球形小流量直通锻造阀。
公称直径(PN)：G1/2"(2-9)-300mm
公称压力(PN)：1.6、4.0、6.4MPa
阀体材料、上阀盖形式、密封填料、介质温度

The main technical index

1. the body

Type: single seat, two seater for direct casting ball valve small flow for through forging valve.
Nominal diameter (PN) : G1/2" (2-9) - 300 mm
Nominal pressure (PN) : 1.6, 4.0, 6.4 MPa
Body materials, valve cover form, packing, medium temperature

阀体材料 Body material	介质温度℃ Medium temperature			接管座标 尺寸 (mm) Over coordinate size	工作温度 范围 (℃) Operating temperature range	D1	D2	D3
	普通型上阀盖 Ordinary type and the valve cover		散热片上阀盖 Fin on the valve cover					
	四氟填料 Four fluorine packing	石墨填料 Graphite packing	四氟填料 Four fluorine packing					
铸铁HT200 Cast iron	-40~+200		-	公称 直径(mm) Nominal diameter	G1/2"、G3/4"、20-50	500	700	900
铸钢ZG230-450 Cast steel	-40~+250		-40~+450		65-100	600	800	1000
铸不锈钢1Cr18Ni9Ti Cast stainless steel	-40~+250		-60~+450		125-100	700	900	1100

注：小流量为锻不锈钢(1Cr18Ni9Ti)；低温阀介质温度 Note: small flow for forging stainless steel (1Cr18Ni9Ti); Cryogenic valve medium temperature

2、阀内组件

型式：小流量，单座阀为单座柱塞型阀芯、阀座；双座阀为双座柱塞型阀芯、阀座。

材料：不锈钢(1Cr18Ni9Ti、316L)；耐腐蚀合金(Monel, Hastelloy B, C等)

2. valve components within

Type: small flow, single seat valve for single seat plunger type valve core and valve seat; Two-seater valve for two-seater plunger type valve core and valve seat.

Material: stainless steel (1Cr18Ni9Ti, 316L); Corrosion resistant alloy (Monel, Hastelloy B, C, etc.)

3、执行机构

型式：ZKZ/DKZ型电动执行机构(包括ZPE-04型伺服放大器)

标准输入电信号：Ⅱ型0-10mA DC、Ⅲ型4-20mA DC

输入电阻：250Ω

输入通道：3个

电源：220V AC、50Hz

4、伺服放大器安装形式：墙挂式、架装式

5、辅助装置：DFD/SFD系列电动操作器

6、环境温度：-25~+60℃(伺服放大器0~+50℃)

7、相对湿度：不大于95%(伺服放大器不大于85%)

8、防爆等级：d II BT3

9、阀作用型式：分电开式和电关式，小流量阀为电关式，DN20采用正作用执行机构，其余均采用反作用执行机构

10、泄漏量：小流量、单座阀<10⁻⁴X阀额定容量，双座阀<5X10⁻⁴X阀额定容量

11、固有可调比：30:1

12、固有流量特性：小流量阀；直线；单、双座阀；对数(等百分比)、直线、快开

13、额定流量系数Kv、允许压差ΔP

3. actuator Type: ZKZ/DKZ type electric actuators (including ZPE-04 type servo amplifier)

Standard input signals: Ⅱ type 0-10 mA DC, Ⅲ type 4-20 mA DC

Input resistance: 250 Ω

Input channel: 3

Power supply: 220 V AC, 50 Hz

4. servo amplifier installation forms: wall hung, rack mounted

5. auxiliary device: DFD/SFD series of electric manipulator

6. environment temperature: -25~+60℃ (servo amplifier 0~+50℃)

7. relative humidity: no more than 95% (servo amplifier is not more than 85%)

8. explosion-proof level: d II BT3

9. valve mode of action: points electric open and electricity shut type, small flow valve for electric close type, 3/4" the positive role actuator, the others all USES reaction actuator

10. leakage: small flow, single seat valve < 10⁻⁴ x valve rated capacity, two-seater valve < 5 x 10⁻⁴ x valve rated capacity

11. inherent adjustable ratio, 30:1

12. the intrinsic flow feature: small flow valve; Straight line; Single, double beat valve; Logarithmic (equal percentage), linear, quick opening

13. rated flow coefficient Kv, allow pressure difference ΔP

公称直径(mm) Nominal diameter		(G1/2"), (G3/4")								
阀座直径(mm) Seat diameter		2	2.5	3	4	5	6	7	8	9
小流量阀 Small flow valve	Kv	0.04	0.06	0.08	0.12	0.20	0.32	0.50	0.80	1.00
	ΔP Mpa	6.4								
额定行程mm Rated stroke		10								
执行机构配置 Actuator configuration		ZKZ/DKZ-2100								

公称直径(mm) Nominal diameter		20											25	32	40	50	65	80	100	125	150	200	250	300				
阀座直径(mm) Seat diameter		10	12	15	20																							
单座 Single seat	Kv	1.2	2.0	3.2	5.0	8	13	22	32	50	80	120	200	280	450	700	1000											
	ΔP Mpa	6.4	6.4	4.25	2.86	1.75	1.07	0.63	0.41	1.83	1.21	0.77	0.48	0.33	0.18	0.31	0.21											
	额定行程mm Rated stroke	10					16			25			40			60			100									
双座 Double seat	Kv	-				10	16	25	40	72	100	160	250	400	630	1000	1600											
	ΔP Mpa	-				6.4	6.4	6.4	5.19	6.4	6.4	6.4	6.4	6.4	6.3	6.4	5.38											
	额定行程mm Rated stroke	-				16			25			40			60			100										
执行机构一般配置 Actuator general configuration		ZKZ/DKZ-2100					ZKZ/DKZ-2200			ZKZ/DKZ-2300			ZKZ/DKZ-4400			ZKZ/DKZ-4500			ZKZ/DKZ-5600									

注：ΔP确定依据，阀关闭P2=0；双座阀流向为中间流进，上下流出，其它阀为底进高出。

Note: ΔP sure basis, valve closed P2 = 0; Two-seater valve flow for intermediate flow into, fluctuation outflow, other valve at the bottom into the above.



ZKZY小流量单座调节阀、ZKZP单座调节阀、ZKZN双座调节阀 ZKZY small flow single seat valve, ZKZP single seat valve, ZKZN two-seater regulator

外形尺寸 Physical size

公称直径(mm) Nominal diameter		G1/2", G3/4"	20	25	32	40	50	65	80	100	125	150	200	250	300	
L mm	PN1.6MPa	-	180	185	200	220	250	275	300	350	410	450	550	670	770	
	PN4.0MPa	-	180	190	210	230	255	285	310	355	425	460	560	740	805	
	PN6.4MPa	80	190	200	210	230	265	295	320	370	440	475	570	750	820	
H mm	小流量阀 Small flow valve	普通型 ordinary	658	-												
		散热片型 ribbed	776	-												
	单座阀 Single seat valve	普通型 ordinary	-	843	871	883	906	936	1182	1198	1206	1330	1346	1424	1776	1900
		散热片型 ribbed	-	970	1001	1013	1036	1066	1345	1361	1369	1529	1545	1621	2078	2146
双座阀 Two-seater valve	普通型 ordinary	-	-	881	887	926	936	1202	1232	1256	1380	1400	1484	1896	2034	
	散热片型 ribbed	-	-	1011	1017	1056	1065	1365	1395	1419	1579	1599	1681	2198	2280	
H1 mm	小流量阀 Small flow valve	-	-													
	单座阀 Single seat valve	19 (19)	93 (74)	112 (99)	118 (105)	129 (117)	144 (132)	178 (165)	191 (168)	195 (177)	243 (255)	251 (233)	290 (272)	381	436	
	双座阀 Two-seater valve	-	-	117 (104)	120 (107)	139 (127)	144 (132)	188 (185)	208 (202)	220 (250)	268 (260)	278 (302)	320	411	503	
L1 mm		340	340												341	
重量 Kg weight	小流量阀 Small flow valve	48	-													
	单座阀 Single seat valve	-	52	54	55	67	71	113	132	146	175	231	365	580	730	
-		-	58	60	71	75	127	140	177	236	292	433	770	930		

注：重量为PN64普通型上调差的阀。H参数不适用于低温型、波纹管密封型（）内参数为低温阀数据
Note: weight for PN64 ordinary type on the valve bonnet. H parameter does not apply to low temperature type, bellows seal type () for cryogenic valve parameters in the data

型号规格 specifications

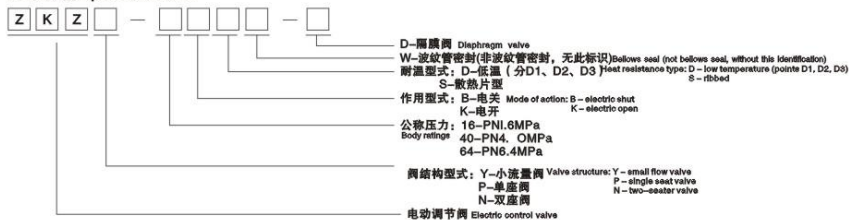

订货注意事项

1、名称、型号 2、公称直径(DN)及额定流量系数(Kv) 3、输入信号 4、阀体材料 5、固有流量特性 6、聚四氟乙烯填料(可不注)或石墨填料 7、伺服放大器安装形式 8、辅助装置 9、其它要求

Order matters needing attention

1. name, type 2. nominal diameter (DN) and the rated flow coefficient (Kv) 3. the input signal 4. the valve body material 5. the intrinsic flow feature of 6. pte packing (don't note) or graphite packing 7. servo amplifier installation form 8. auxiliary device 9. other requirements

ZAZT、ZAZTC型电动隔膜调节阀 ZAZT、ZAZTC type electric diaphragm valve



概述

ZAZT、ZAZTC型电动隔膜调节阀由DKZ电动执行机构和隔膜调节阀组成，以220V AC电源为动力，接受标准信号0-10mA DC或4-20mA DC的信号，实现对工艺管道中强酸、强碱等腐蚀性介质及高粘度、有害介质的流量调节与控制。应用于石油、化工、冶金等耐腐蚀系统中。

产品特点：阀流通阻力小，流通能力大，无填料函，无外泄漏，具有耐腐、防火、防毒、安全可靠的特点，可根据不同衬里和隔膜，获得良好的耐腐蚀性能。

产品符合JB/T7387-1994。

overview

ZAZT, ZAZTC type electric diaphragm valve by DKZ electric actuators and diaphragm valve is composed, by 220V AC power supply for power, accept standard signal 0-10 mA DC or 4-20 mA DC electrical signal to realize the process of strong acid, strong alkali, etc in the pipe corrosion medium and high viscosity and harmful medium flow regulation and control. Used in petroleum, chemical industry, metallurgy, corrosion resistant system.

Product features: valve small flow resistance, flow capacity big, no stuffing box, no external leakage, with corrosion resistance, fire prevention, antiviral, safe and reliable characteristic, according to different lining and diaphragm, get good corrosion resistance.

Product complies with JB/T7387-1994.

主要技术参数 Main technical parameters

公称直径(mm) Nominal diameter	15	20	25	32	40	50	65	80	100	125	150	200	250
额定流量系数Kv Rated flow coefficient	8	12	16	38	60	68	90	150	300	500	600	1200	2000
公称压力(MPa) Nominal pressure	1.0												
执行机构 Actuator	II型 II Type	DKZ-310		DKZ-310		DKZ-310		DKZ-410		DKZ-410		DKZ-510	
	III型 III Type	DKZ-310C		DKZ-310C		DKZ-310C		DKZ-410C		DKZ-410C		DKZ-510C	
	有效推力(N) Effective thrust	1000			4000			6400					
	工作行程(mm) Operating stroke	10			16			25			40		
允许压差 Allow differential pressure	P1=ΔP	1.0	0.89	1.0	1.0	1.0	1.0	1.0	0.6	0.38	0.15	0.30	
	P1=P2	1.0	0.44	1.0	1.0	0.75	0.9	0.55	0.3	0.19	0.075	0.085	
法兰标准 Flange standards	JB78-59												
流量特性 Characteristics	近似快开(调节式) Approximate quick opening (adjustable)												
电源电压 Power supply voltage	220V AC 50 Hz												
出厂状态 Factory state	电开(如需电关, 订货时应注明) Electric drive (such as the need to electric shut, when you place an order should indicate)												

性能指标 Performance index

项目 project	指标值 Index value
基本误差% Basic main difference	±3.5
回差% Return difference	≤2.5
死区% Dead zone	≤3
始终点偏差 Always point deviation	±2.5
额定行程偏差% Rated stroke deviation	±2.5
纯滞后 Pure lag	≤1s
允许泄漏量L/h Allow leakage	橡胶隔膜片为“O”，聚四氟乙烯隔膜片为0.5%×阀额定容量(许用压差下的水) Rubber diaphragm piece as the "O", pte diaphragm is 0.5% × valve rated capacity (allowable pressure difference of water)
绝缘电阻 Insulation resistance	不小于20MΩ Not less than
阻尼特性 Damping characteristics	不大于3周半 No more than three and a half weeks



ZAZT、ZAZTC型电动隔膜调节阀 ZAZT、ZAZTC type electric diaphragm valve

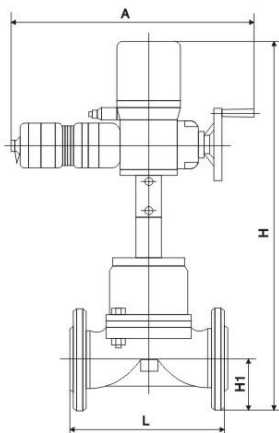

外形尺寸 Physical size

公称直径(mm) Nominal diameter	ZAZT型				ZAZTC型			
	A	H	H ₁	L	A	H	H ₁	L
15	460	514	48	140	340	754	48	140
20	460	515	53	145	340	755	53	145
25	460	520	58	155	340	760	58	155
32	460	525	68	165	340	765	68	165
40	460	527	73	190	340	767	73	190
50	460	530	80	210	340	770	80	210
65	460	540	90	240	340	780	90	240
80	530	590	98	270	430	1182	98	270
100	530	595	108	335	430	1188	108	335
125	630	687	123	375	430	1280	123	375
150	630	695	140	410	430	1288	140	410
200	630	728	168	540	430	1321	168	540
250	630	733	200	650	430	1386	200	650

阀体材质、衬里和隔膜片代号 Body material and lining and diaphragm piece of code

基体和衬里 Matrix and lining	HT200			ZG1Cr18Ni9Ti	隔膜片 Diaphragm tablet		
	无 No	衬F46	衬F3		氯丁橡胶 Chloroprene rubber	氟橡胶 Fluorine rubber	F46
代号 code	1	3	2	4	1	3	2

订货须知

订货时请填写《规格书》或注明以下内容:

1.产品型号 2.公称直径 3.公称压力 4.使用介质 5.介质温度 6.衬里材料 7.阀体材料 8.特殊要求及附件

Order instructions

When ordering, please fill in 《specification》 or indicate the following contents:

1. The product model 2. Nominal diameter 3. Nominal pressure 4. Use medium 5. Medium temperature 6. Lining material 7. The body material 8. Special requirements and accessories



调节球阀系列 Regulating ball valve series

ZDJR、ZKJR、Q941F系列电动O型调节球阀 ZDJR、ZKJR、Q941F series of electric type O regulating ball valve

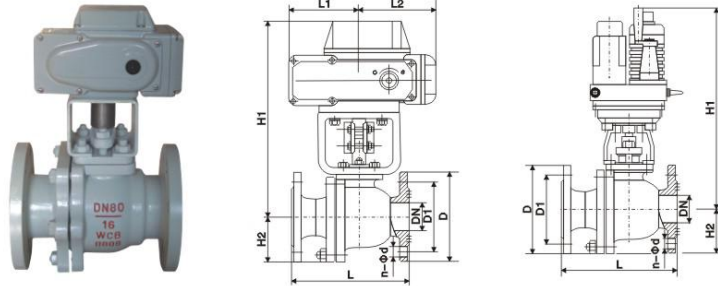

概述

ZDJR、ZKJR、Q941F系列电动O型调节球阀是一种转角为90°的旋转类调节阀，密封性能优良，流通能力大，流阻小，结构简单、维修方便、使用寿命长，配用DKJ-II、III执行器配日本工美、西德欧姆龙等高性能执行机构。产品通常用于密封要求严格的场合，除控制气体、液体、蒸汽介质外，还适宜控制污水和含有纤维性杂质的介质，广泛用于石油、化工、冶金、轻工、造纸、电站、制冷等工业领域。

Overview

ZDJR、ZKJR、Q941F series of electric type O regulating ball valve is a kind of Angle for 90° rotation kind of regulating valve, sealed performance is good, flow capacity big, flow resistance coefficient is small, simple structure, convenient maintenance, long service life, with DKJ-II, III actuator lead with Japan tooling, west Germany omron and high performance actuator. Products are normally used to seal demanding occasions, in addition to control gas, liquid, steam medium outside, still suitable for control of sewage and contain fibrous impurity medium, widely used in petroleum, chemical industry, metallurgy, light industry, paper making, power stations, refrigeration and other industrial fields.

主要技术参数和性能 Main technical parameters and performance

公称直径(mm) Nominal diameter	15	20	25	32	40	50	65	80	100	125	150	200	250	300	350	400
额定流量系数Kv Rated flow coefficient	17	33	62	95	146	232	350	439	810	1205	1912	3014	4306	6540	8750	11800
公称压力(MPa) Nominal pressure	PN1.6, 6.4MPa															
连接型式 Connection type	法兰连接, 按JB79-59标准 Flange connection, regulation according to JB79-59 standard															
球阀转角 Ball valve Angle	90°															
阀体材料 Body material	铸钢、铸不锈钢 Cast steel, Cast stainless steel															
适用温度 Suitable temperature	常温型-40℃~180℃; 高温型-40℃~450℃ Cold type -40℃~180℃; High temperature type -40℃~450℃															
执行机构 actuator	DKJ-II、III型PS AUTOMATION CMBH、LNAR-KOSO、Unio-Z电动执行机构 DKJ-II, III type PS AUTOMATION CMBH, LNAR-KOSO, Unio-Z electric actuators															
输入信号 Input signal	0-10mA 4-20mA 1~5V DC															
基本误差 Basic main difference	≤全行程的±2.5% ≤Full stroke of ±2.5%															
回差 Return difference	≤全行程的2% ≤Full stroke of 2%															
死区 Dead zone	≤全行程的3.0% ≤Full stroke of 3.0%															
泄漏量 leakage	软密封, JB/T7387-94表2中的V级 硬密封, JB/T7387-94表2中的VI级 JB/T7387-94标准表2见附表 Soft seal, JB/T7387-94 in table 2 grade V hard seal, JB/T7387-94 table 2 roller VI level JB/T7387-94 standard table 2 see form															

ZSHV、ZSSV系列气动V型调节球阀 ZSHV、ZSSV series pneumatic v-type regulating ball valve

概述

ZSHV型系列气动V型球阀，球芯呈V型状，可实现线性调节，可调节范围大。当阀门关闭时，V形缺口与阀座之间产生楔形密封作用并既具有自洁功能又可防止球芯卡死，特别适用于管线结垢堵塞场合。适用于控制纸浆、污水，含有纤维和颗粒固体悬浊液及粉粒状介质。配用的ZGH系列气缸活塞式执行机构，结构简单，输出力矩大。本系列球阀按密封性能分为软密封和硬密封；按调节方式分为调节型和切断型，切断型按作用型式分为单作用式和双作用式，调节型为双作用式。单作用式的独特优点是一旦动力源发生故障，球阀将按控制器的要求自动处于关闭或开启位置。产品广泛应用于电力、石油、化工、造纸、轻纺、食品、制药、航空航天等领域。

Overview

ZSHV type series pneumatic V ball valve, ball core is V shape, can realize linear adjustment, adjustable range. When the valve is closed, v-notch and seat occurs between wedge shearing action, and both has sanctified function and can prevent the ball core card dead, especially suitable for pipeline scaling freezing occasion. Suitable for the control pulp, waste water, contain fiber and particle solid suspension turbidity medium and powder granular media. With the ZGH series cylinder piston type actuator, the structure is simple, the output torque. This series of ball valve sealing performance according to the divided into soft seal and hard seal; According to the regulation mode is divided into DiaJieXing and cutting type, cut off type according to the mode of action is divided into single acting and double acting, DiaJieXing for double acting. Single acting unique advantage is that once the power supply malfunction, ball valve will be made according to the requirement of automatic control system in the closed or open position. The products are widely used in electric power, petroleum, chemical industry, papermaking, textile, food, pharmaceutical, aerospace and other fields.

主要技术参数和性能 Main technical parameters and performance

型式 Type	直通式铸造球阀 Straight-through casting ball valve															
公称直径(mm) Nominal diameter	25	32	40	50	65	80	100	125	150	200	250	300	350	400		
阀座直径 Seat diameter	20	26	33	40	53	66	86	104	128	170	212	255	300	340		
额定流量系数Kv Rated flow coefficient	25	36	63	100	184	280	400	600	950	1540	2500	3900	6150	9800		
公称压力(MPa) Nominal pressure	PN1.6, 6.4MPa															
泄漏量 leakage	软密封: ≤1.8X10 ⁻⁷ XΔPXDN.1/h(试验介质为液体: 式中ΔP为压差) 硬密封: ≤10 ⁻⁶ X阀额定容量.1/h(阀额定容量的计算见附表) Soft seal: ≤1.8X10 ⁻⁷ XΔPXDN.1/h(test medium for liquid; Type of ΔP for differential pressure) Hard seal: acutiles 10 ⁻⁶ xvalve rated capacity.1/h (valve rated capacity calculation see the appendix)															
气源压力 Air pressure	0.4~0.6MPa															
连接型式 Connection type	对夹式、法兰式、管道法兰按JB79-59标准 Wafer, flange, pipeline flange regulation according to JB79-59 standard															
适用温度 Suitable temperature	软密封-40℃~+180℃; 硬密封-40℃~+450℃ Soft seal -40℃~+180℃; Hard seal -40℃~+450℃															
球阀转角 Ball valve Angle	90°															
流量特性 Characteristic	近似等百分比(典型曲线图见附表) Approximate equal percentage (typical chart see the appendix)															
阀体材料 Body material	A105、F321、F316、WCB、ZG1Cr18NiTi、ZG0Cr18Ni12Mo2Ti、ZG00Cr17Ni14Mo2															
球芯型式 Ball core type	部分球带有V形缺口 Part of the ball with V notch															
阀座材料 Seat materials	聚四氟乙烯、不锈钢可太立硬质合金 Teflon, stainless steel company too made hard alloy															
基本误差 Basic main difference	≤全行程的±2%(带定位器) ≤Full stroke of ±2%(with locstor)															
回差 Return difference	≤全行程的2.0%(带定位器) ≤Full stroke of 2.0%(with locstor)															
死区 Dead zone	≤全行程的0.8%(带定位器) ≤Full stroke of 0.8%(with locstor)															
额定流量系数误差% Rated flow coefficient of the error	≤±10															

主要配置附件

调节型: 电气阀门定位器、空气过滤减压器、手轮机构等
准切断型: 空气过滤减压器、电磁阀、两位开关、手轮机构等

Main configuration accessory

DiaJieXing: electric valve positioner, air filtration pressure reducer, hand wheel mechanism, etc
Must cut off type: air filtration pressure relief valve, solenoid valve, valve position switch, hand wheel mechanism, etc

外形及连接尺寸 Appearance and connection dimension

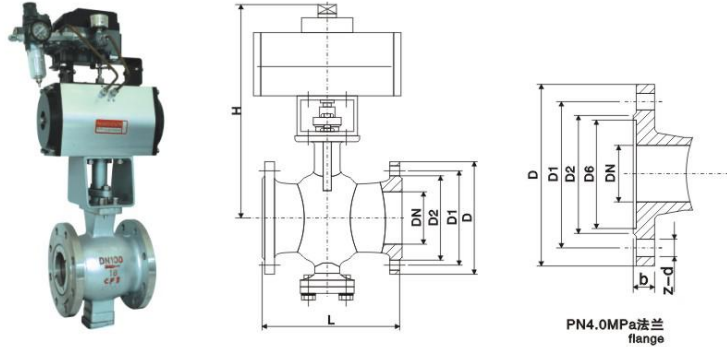

公称压力 (MPa) Nominal pressure	公称口径 (mm) Nominal diameter	尺寸(mm) size								
		L	对夹连接 For clamp connection	法兰连接 Flange connection						H
			D	D	D1	D2	D6	b	z-d	
1.6	25	102	64	115	85	65		14/16	4-14	233
	40	114	82	145/150	110	85/84	-	16/18	4-18	280
	50	124	100	160/165	125	100/99	-	18/20	4-18	362
	65	145	118	180/185	145	120/118	-	18/20	4-18	377
	80	165	130	195/200	160	135/132	-	20	8-18	410
	100	194	155	215/220	180	155/156	-	20/22	8-18	423
	125	210	185	245/250	210	185/184	-	22	8-18	436
	150	229	216	280/285	240	210/211	-	24	8-23/8-22	653
	200	243	264	335/340	295	265/266	-	26/24	12-23/12-22	703
	250	297	328	405	355	320/319	-	30/26	12-25/12-26	787
2.5	300	338	373	460	410	375/370	-	30/28	12-25/12-26	827
	25	102	64	115	85	65	-	16	4-14	233
	40	114	82	145/150	110	85/84	-	18	4-18	280
	50	124	100	160/165	125	100/99	-	20	4-18	362
	65	145	118	180/185	145	120/118	-	22	8-18	377
	80	165	130	195/200	160	135/132	-	22/24	8-18	410
	100	194	155	230/235	190	160/156	-	24	8-23/8-22	423
	125	210	185	270	220	188/184	-	28/26	8-25/8-26	436
	150	229	216	300	250	218/211	-	30/28	8-25/8-26	653
	200	243	264	360	310	278/274	-	34/30	12-25/12-26	703
250	297	328	425	370	332/330	-	36/32	12-30	787	
300	339	373	485	430	390/389	-	40/34	16-30	827	

公称压力 (MPa) Nominal pressure	公称口径 (mm) Nominal diameter	尺寸(mm) size								
		L	对夹连接 For clamp connection	法兰连接 Flange connection						H
			D	D	D1	D2	D6	b	z-d	
4.0	25	102	68	115	85	65	58	16	4-14	262
	40	114	88	145/150	110	85/84	76	18	4-18	280
	50	124	102	160/165	125	100/99	88	20	4-18	362
	65	145	122	180/185	145	120/118	110	22	8-18	400
	80	165	138	195/200	160	135/132	121	22/24	8-18	403
	100	194	162	230/235	190	160/156	150	24	8-23/8-22	616
	125	210	188	270	220	188/184	176	28/26	8-25/8-26	643
	150	229	218	300	250	218/211	204	30/28	8-25/8-26	685
	200	243	285	375	320	282/284	260	38/34	12-30	747
	250	297	345	445/450	385	345	313	42/38	12-34/12-33	933
6.4	300	338	410	510/515	450	408/409	364	46/42	16-34/16-33	980
	25	102	68	135/140	100	78	58	22	4-18	262
	40	114	88	165/170	125	95	76	24	4-23	280
	50	124	102	175/180	135	105	88	26	4-23	362
	65	145	122	200/205	160	130	110	28	8-23	400
	80	165	138	210/215	170	140	121	30	8-23	603
	100	194	162	250	200	188	150	32	8-25	616
	125	210	188	295	240	202	176	36	8-30	643
	150	229	218	340/345	280	240	204	38	8-34	685
	200	243	285	405	345	300	260	44	12-34/12-26	747
250	294	345	470	400	352	313	48	12-41/12-36	933	
300	338	410	530	460	412	364	54	16-41/16-36	980	

注：对夹式“L”同法兰连接的“L”一样。（包括所有压力） Note: wafer "L" with flange connection "L". (Including all pressure)

订货须知
订货时填写《规格书》或注明以下内容：

- 1、产品型号
- 2、公称口径 阀座直径
- 3、公称压力
- 4、阀体和阀内组件材料
- 5、适用温度
- 6、调节方式
- 7、双作用或单作用（单作用请注明气开式或气闭式）
- 8、是否带附件
- 9、连接型式

本厂可按用户要求供货

Order instructions

When ordering, fill in (specification) or indicate the following contents:

1. product model
2. nominal diameter seat diameter
3. nominal pressure
4. body and valve components within material
5. suitable temperature
6. regulating mode
7. double action or single action (single acting please indicate the gas open or gas closed)
8. whether or not to bring accessories
9. connection type

we can supply according to the requirements of customers

电动三通O型球阀由电动执行机构和三通球阀组成。通过改变球芯与管道的相对位置,可以对三条管路流体实行不同的组合控制。该产品以220V单相交流电为电源,接受控制系统(或操作器)来的220V开关信号,并通过单相电源切换驱动可逆单相齿轮减速电机,按规定的组合要求,使球阀实现对管路流体的换向作用。

T型三通可使三路正交的管道互相连通,即起分流(合流)作用,也可使其中两条管道连通而切断另一条管道。

L型三通只能连通互相正交的两条管道或切换方向,即起分配作用。

Electric 3-way ball valve type O by electric actuators and three-way ball valve composition. By changing the ball core and the relative position of the pipeline, the three line fluid implement different combination control.

The products to 220 v single phase alternating current (ac) do source, accept control system (or manipulator) to 220 v switching signal, and through the single-phase power supply switch drive reversible single-phase geared motor, press

The combination of the regulation requirements, make the ball valve realize the line fluid reversing function.

T tee can make the three way orthogonal pipe connected each other, that is, the shunt (junction) effect, also can make the two pipe connected and cut off another line.

L tee can only be connected are perpendicular to each other two pipe or switch direction, that is, the distribution function.

阀体 Body

型式 Type	二开式铸造球阀 Two open casting ball valve
公称直径(mm) Nominal diameter	DN15~300mm
公称压力(MPa) Nominal pressure	PN1.6、2.5、4.0、6.4MPa ANSI 150、300 JIS 10K、20K
连接形式 Connection form	法兰连接: RF、凹凸式 Flange connection: RF, lenticular 法兰标准 Flange standard: JB/T 79-94 ANSI B16.5-1981 JIS B2201-1984
材料 Material	WCB、ZG1Cr18Ni9Ti、ZG0Cr18Ni12Mo2Ti (CF8、CF8M、CF3、CF3M) (SCPH2、SCS13A、SCS14A)
上阀盖 On valve cover	标准型: 与阀体一起铸造 Standart: with the valve body with casting
工作温度 Working temperature	-20~+180℃ -20~300℃(阀座材料对位聚苯) -20~+180℃ -20~300℃(The seat material para polystyrene)
填料 Packing	聚四氟乙烯、石墨 Ptfе and graphite

阀内组件 Valve components within

阀芯形式 Valve core form	T型、L型球阀阀芯 T、L ball valve core
流量特性 Flow characteristic	快开特性 Quick opening characteristics
阀座 Seat	聚四氟乙烯、增强聚四氟乙烯、对位聚苯 Teflon, enhance teflon, para polystyrene
材料 Material	2Cr13、1Cr18Ni19Ti、0Cr18Ni12Mo2Ti、Ti(CF8、CF8M、CF3、CF3M)
阀芯转角 Valve core Angle	90°

执行机构 Actuator

型式 Type	3410R电动执行机构(可配德国PSQ、国产DKJ、SJ及智能电动执行机构IWK系列) 3410 r electric actuator (can match the German PSQ, domestic DKJ, SJ and intelligent electric actuators IWK series)
输入信号 Input signal	220VAC正反切换信号 220 vac and switching signal
供电电源 Power supply	220V/50Hz 380V(IWK系列)220V/50Hz 380V(IWK Series)
手动机构 Manual mechanism	便携式手动曲柄 Portable hand crank
作用型式 Mode of action	根据信号转换控制阀开、阀关 According to the signal conversion control valve open and close the valve

额定流量系数KV、额定行程 The rated flow coefficient KV, rated stroke

公称直径(mm) Nominal diameter	50	80	100	150	200	250	300
额定流量系数KV Rated flow coefficient	50	150	270	440	880	1500	2300
额定行程 Rated stroke	90°						

泄漏量 leakage

常温球阀(聚四氟乙烯阀座), 试验介质为水 Cold ball valve (ptfe seat), the test medium for water

公称直径(mm) Nominal diameter	15	20	25	40	50	65	80	100	150	
泄漏量 ml/min leakage	PN1.6	0.08	0.11	0.13	0.21	0.27	0.35	0.43	0.53	0.80
	PN4.0	0.32	0.43	0.53	0.85	1.1	1.4	1.7	2.1	3.2
	PN6.4									

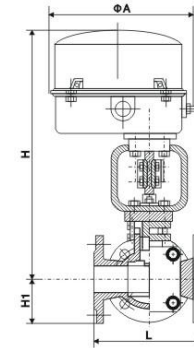

阀控制方式 Valve control mode

L型三通双口 L t duplex

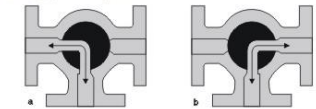

L型 Type

T型三通双口 T T duplex



T型 Type

电动执行机构主要技术性能 Electric actuators main technical performance

类别 Category	型号 Model	输出力矩N.M Output torque	动作时间(S/90°) Action time	最大转角 Maximum Angle	技术参数 Technical parameters
普通型 Ordinary	341RSA-02	20	8.5	90°	电源 power: 220VAC±10% 50Hz 输入信号 Input signal: 220VAC 1-5VDC 正反切换信号 Positive and negative switching signal 输出开度信号 Output opening signal 4-20mA DC或 0-10K电位器 Potentiometer 防护等级 Protection level IP55 防爆等级 Explosive-proof grade ExdIIBT4
	341RSA-05	50	17		
	341RSB-10	100	18		
	341RSB-20	200	36		
	341RSC-30	300	24		
	341RSC-50	500	42		
	341RSC-60	600	48		
	341RSD-100	1000	30		
防爆型 Namur	341RXB-10	100	18		
	341RXB-20	200	36		

外形尺寸 Physical size

公称直径(mm) Nominal diameter	H	L	H1	ΦA
15	440	150	44.5	225
20	450	150	49	225
25	470	180	55	225
32	490	200	65	225
40	500	220	65	225
50	620	240	75	225
65	640	260	90	335
80	660	280	95	335
100	685	320	115	335
125	730	380	127	335
150	880	440	140	335

订货须知 Order instructions

1、产品型号 2、公称直径 3、公称压力 4、阀体材料 5、阀控制方式 6、工作温度 7、使用介质
1. product model 2. nominal diameter 3. nominal pressure 4. the valve body material 5. valve control mode 6. working temperature, 7. the use of medium

精小型气动三通O型球阀由气动活塞执行机构和三通球阀组成。改变球芯与管道的相对位置，可以对三条管路流体实行不同的组合控制。该产品以压缩空气为动力源，接受控制系统的开关信号，通过电磁阀换向，操作球阀按规定要求对管路进行切换。

T型三通可使三路正交的管道互相连通即起分流(台流)作用，也可使其中两条管道连通而切断另一条管道。

L型三通只能连通互相正交的两条管道或切换方向，即起分配作用。

三通阀按照作用方式分担作用和双作用两种方式，单作用的特点是一旦动力源发生故障时，球阀将处于控制系统要求的状态。

Pneumatic t O type ball valve by pneumatic piston actuators and three-way ball valve composition. Change the ball core and the relative position of the pipeline, the three line fluid implement different combination control.

This product to compressed air to power sources, accept control system switching signal, through the electromagnetic valve reversing, operation ball valve according to the stipulation request to line switch.

T T can make three way orthogonal pipes connected to each other that is, the shunt (junction) effect, also can make the two pipe connected and cut off another line.

L tee can only be connected are perpendicular to each other two pipe or switch direction, that is, the distribution function.

Three-way valve, in accordance with the mode of action sharing function and double action in two ways, single acting characteristic is once power supply malfunction, ball valve will be in control system requirements of the state.

阀体 Body

型式 Type	两开式铸造球阀 Two open casting ball valve
公称直径(mm) Nominal diameter	DN15-150mm
公称压力(MPa) Nominal pressure	PN1.6、2.5、4.0、6.4MPa ANSI 150、300 JIS 10K、20K
连接形式 Connection form	法兰连接: RF、凹凸式 Flange connection: RF, lentiolar 法兰标准 Flange standard: JB/T 79.1-94 ANSI B16.5-1981 JIS B2201-1984
材料 Material	WCB、ZG1Cr18Ni9Ti、ZG0Cr18Ni12Mo2Ti (CF8、CF8M、CF3、CF3M) (SCPH2、SCS13A、SCS14A)
上阀盖 On valve cover	标准型: 与阀体一起铸造 Standard: with the valve body with casting
工作温度 Working temperature	-20~+180℃ -20~300℃(阀座材料对位聚苯 The seat material para polystyrene)
填料 Packing	聚四氟乙烯、石墨 Pte and graphite

阀内组件 Valve components within

阀芯形式 Valve core form	T型、L型球阀芯 T、L ball valve core
流量特性 Flow characteristic	快开特性 Quick opening characteristics
阀座 Seat	聚四氟乙烯、增强聚四氟乙烯、对位聚苯 Teflon, enhance teflon, para polystyrene
材料 Material	2Cr13、1Cr18Ni19Ti、0Cr18Ni12Mo2Ti、Ti(CF8、CF8M、CF3、CF3M)
阀芯转角 Valve core Angle	90°

执行机构 Actuator

型式 Type	GTx单作用气动活塞执行机构(带弹簧复位) GTD双作用气动活塞执行机构 GTx single-acting pneumatic piston actuator (with spring reset) GTD double-acting pneumatic piston actuator
供气压力 Gas supply pressure	0.4-0.7MPa
气源接口 Air Interface	1/4NPT
阀作用型式 Valve mode of action	单作用: 气关式或气开式 Single action: gas close type or gas open 双作用: 根据信号转换控制阀开、阀关 Double action: according to the signal conversion control valve open and close the valve

附件(根据要求配置)

电磁阀, 空气过滤减压阀, 手轮机构, 限位开关, 阀位变送器, 气动加速器, 保位阀, 其它。

Accessories (according to requirements configuration)

Electromagnetic valve, air filtration pressure reducing valve, the handwheel institutions, limit switch, Valve position transmitter, pneumatic accelerator, protect a valve, and other.

电磁阀、限位开关、空气过滤减压器等 Electromagnetic valve, valve position switch, air filtration reducer, etc

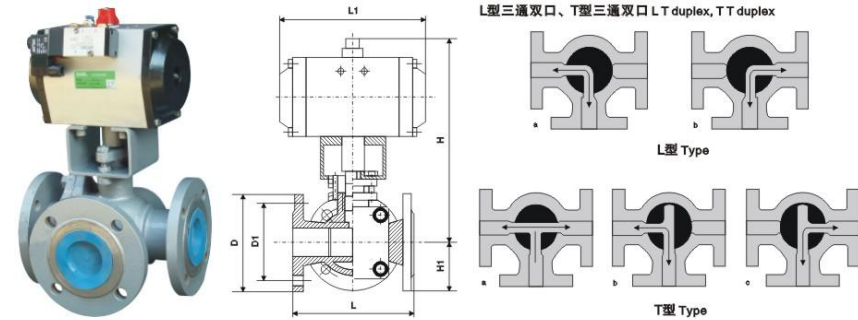

泄漏量 leakage

公称直径(mm) Nominal diameter	15	20	25	40	50	65	80	100	150	
泄漏量 ml/min leakage	PN1.6	0.08	0.11	0.13	0.21	0.27	0.35	0.43	0.53	0.80
	PN4.0	0.32	0.43	0.53	0.85	1.1	1.4	1.7	2.1	3.2
	PN6.4									

主要外形尺寸 The main physical size

公称直径(mm) Nominal diameter	15	20	25	32	40	50	65	80	100	125	150
L1	127	133	133	177	177	177	216	290	290	368	150
H1	48	53	58	68	73	80	90	98	108	123	140
H	231	231	231	243	279	286	362	371	447	583	610
L	150	150	160	200	220	240	260	280	320	380	440
D1	65	75	85	100	110	125	145	160	180	210	240
D	95	105	115	135	145	160	180	195	215	245	280

订货须知

- 1、产品型号
- 2、公称直径
- 3、公称压力
- 4、阀体材料
- 5、法兰连接形式
- 6、球芯形式
- 7、控制方式
- 8、单作用或双作用(单作用请注明气开或气关)及阀控制方式
- 9、阀座材料
- 10、附件

- 1、The product model
- 2、Nominal diameter
- 3、Nominal pressure
- 4、The valve body material
- 5、Flange connection form
- 6、Ball core form
- 7、Control mode
- 8、Eight, single or double acting role (single acting please indicate the gas on or gas off) and valve control mode
- 9、The seat material
- 10、Accessories

切断阀系列

Cut-off valve series

ZSHR、ZSHO系列气动O型切断球阀

ZSHR、ZSHO series pneumatic O-type cutting ball valve

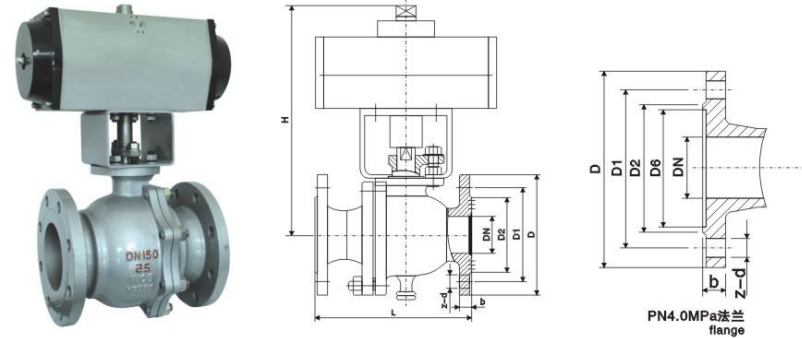

概述

ZSHR系列气动O型球阀，球芯采用O型通孔，固定球式阀门阀座采用弹性补偿阀前密封，双保护盖式填料函装置，保护阀杆在压力下不致脱出，阀内腔能自动泄压，防止阀腔内产生非正常高压，可设置防静电防火结构，阀门的流量系数大，流阻小，角行程启闭迅速。

Overview

ZSHR series pneumatic O type ball valve, ball core using O type through hole, fixed ball type valve valve seat is elastic compensation valve former seal, double protection cover type gland device, valve rod under pressure from emerge, in the valve cavity can automatic relief, prevent the valve cavity produce abnormal high pressure, can be installed antistatic fire structure, valve flow coefficient is big, flow resistance is small, the angular travel opening and closing fast.

用途

适用于石油化工、冶金、制药、食品、造纸、轻纺、电力、给排水等系统，控制一切腐蚀性或非腐蚀性的气体、液体介质。

Use

Used in petroleum chemical industry, metallurgy, pharmacy, food, paper, textile, electric power, water supply and drainage system, control everything corrosion or non corrosive gas, liquid medium.

主要技术参数和性能 Main technical parameters and performance

公称通径(mm) Nominal diameter	DN15 ~ DN400
公称压力(MPa) Nominal pressure	1.6、4.0、6.4MPa、ANS1150、300(Lb)、JIS10、20K
适用介质 Applicable medium	水、石油、硝酸类、醋酸类、粘性流体、浆料、强氧化性介质等 Water, oil, nitric acid, acetic acid, class category, viscous fluid, pulp, strong oxidizing medium, etc
介质温度 Medium temperature	-40~+180℃ -40~+305℃
泄漏量 leakage	0符合ANSI B16.104 5级标准 0 conform to the ANSI B16.104 5 level standard
球体转角 Sphere Angle	90°
阀体材质 Body material	A105、F304、F316、WCB、FZG1Cr18Ni9Ti、ZG1Cr18Ni12Mo2Ti、CF8\CF8M\CF3M
阀座材料 Seat materials	聚四氟乙烯(常温)、特制PPL(高温) Teflon (room temperature), special PPL (high temperature)
防爆级组 Explosion-proof grade group	d11BT4(d2C4) (可供普通型、防爆型二种规格) d11BT4 (d2C4) (available for ordinary type, explosion-proof two types of specifications)
电磁阀电源 Electromagnetic valve power supply	220VAC、24VDC
气源压力MPa Air pressure	0.4~0.7MPa
固有可调比R Inherent Rangeability	100:1

ZSHR、ZSHO-1.6精小型气动O型切断球阀外形及连接尺寸
ZSHR、ZSHO - 1.6 fine small pneumatic O-type cutting ball valve shape and connection dimension

公称压力 (MPa) Nominal pressure	公称直径 (mm) Nominal diameter	尺寸(mm) size							
		L	D	D1	D2	D6	b	z-d	-
1.6	15	130	95	65	45/46	-	14	4-14	196
	20	140	105	75	55/56	-	14/16	4-14	201
	25	150	115	85	65	-	14/16	4-14	203
	32	165	135/140	100	78/76	-	16/18	4-18	240
	40	180	145/150	110	85/84	-	16/18	4-18	248
	50	200	160/165	125	100/99	-	16/20	4-18	330
	65	220	180/185	145	120/118	-	18/20	4-18	340
	80	250	195/200	160	135/132	-	20	8-18	378
	100	280	215/220	180	155/156	-	20/22	8-18	400
	125	320	245/250	210	185/184	-	22	8-18	633
	150	360	280/285	240	210/211	-	24	8-23/8-22	653
	200	457	355/340	295	265/266	-	26/24	12-23/12-22	749
	250	533	405	355	320/319	-	30/26	12-25/12-26	963
	300	610	460	410	375/370	-	30/28	12-25/12-26	1013
	350	686	520	470	435/429	-	34/30	16-25/16-26	1065
	400	762	580	525	485/480	-	36/32	16-30	1115
450	864	640	585	545/548	-	40/34	20-30	1115	
500	914	705/715	650	608/609	-	44/36	20-34/20-33	1205	

ZSHR、ZSHO-6.4精小型气动O型切断球阀外形及连接尺寸
ZSHR、ZSHO - 6.4 fine small pneumatic O-type cutting ball valve shape and connection dimension

公称压力 (MPa) Nominal pressure	公称直径 (mm) Nominal diameter	尺寸(mm) size							
		L	D	D1	D2	D6	b	z-d	H
6.4	15	140	105	75	55	40	18	4-14	196
	20	152	125/130	90	68	51	20	4-18	201
	25	165	135/140	100	78	58	22	4-18	232
	32	178	150/155	110	82	66	24	4-23	240
	40	190	165/170	125	95	76	24	4-23	248
	50	216	175/180	135	105	88	26	4-23	330
	65	241	200/205	160	130	110	28	8-23	363
	80	283	210/215	170	140	121	30	8-23	571
	100	305	250	200	168	150	32	8-25/8-26	593
	125	381	295	240	202	176	36	8-30	669
	150	403	340/345	280	240	204	38	8-34	689
	200	502	405	345	300	260	44	12-34/12-36	913
	250	568	470	400	352	313	48	12-41/12-36	963
	300	648	530	460	412	364	54	16-41/16-36	1020
	350	762	595/600	525	475	422	60	16-41	1162
	400	838	670	585	525	474	66	16-48/16-42	1212

ZSHO型气动三块式外形及连接尺寸
ZSHO type pneumatic three block type appearance and connection dimension

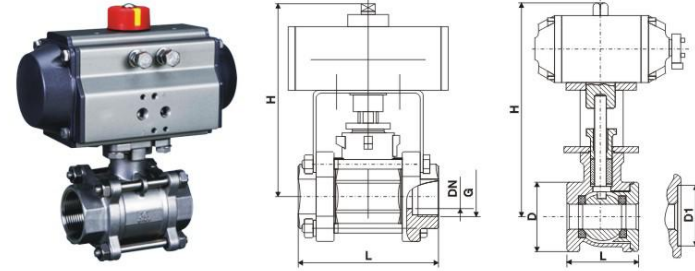

ZSHO型气动三块式外形及连接尺寸
ZSHO type pneumatic three block type appearance and connection dimension

公称直径(mm) Nominal diameter		尺寸(mm) Size				
mm	in	L		G	L0	H
		系列1 series	系列2 series			
10	3/8	55	65	3/8	95	198
15	1/2	65.5	75	1/2	110	201
20	3/4	76	80	3/4	110	206
25	1	86	90	1	140	211
32	5/4	102	110	5/4	140	250
40	3/2	117	120	3/2	180	255
50	2	128	140	2	180	332
65	5/2	165	170	5/2	200	364
80	3	183	190	3	250	578
100	4	200	216	4	250	600

ZGHRD - 1.6
ZGQRD - 4.0 精小型气动对夹式O型切断球阀外形及连接尺寸

ZGHRD - 1.6
ZGQRD - 6.4 精小型气动对夹式O型切断球阀外形及连接尺寸

公称直径 (mm) Nominal diameter	1.6			4.0			6.4			
	L	D	H	L	D	H	L	D	H	D1
10	50	41	225	58	43	225	58	43	225	35
15	55	50	235	63	50	235	65	55	235	40
20	60	60	240	68	60	240	70	68	240	51
25	65	72	245	73	72	245	75	78	245	58
32	70	83	255	78	83	255	80	85	255	66
40	80	90	270	88	90	270	90	95	270	76
50	90	100	275	98	100	275	98	105	275	88
65	120	115	287	128	115	287	128	130	287	110
80	135	130	293	148	130	293	148	140	293	121

订货须知

订货时填写《规格书》或注明以下内容:

1. 产品型号
2. 公称直径
3. 公称压力
4. 阀体和阀内组件材料
5. 介质温度
6. 双作用或单作用(单作用请注明气开式或气闭式)
7. 是否带附件(标准附件: 电磁调、行程开关、空气过滤减压器等)
8. 特殊要求

Order instructions

When ordering, fill in (specification) or indicate the following contents:

1. The product model
2. Nominal diameter
3. Nominal pressure
4. The valve body and internal valve components material
5. Medium temperature double action or single action (single acting please indicate the gas open or gas closed)
7. Whether or not to bring a accessories (standard accessories: solenoid valve, travel switch, air filtration pressure reducer, etc.)
8. Special requirements

电动O型衬氟切断球阀是由NA系列电动执行机构和衬氟球阀组成。阀芯采用衬氟圆柱型通孔球体结合软密封副。该产品阀体内壁和金属阀内组件衬有耐腐蚀、抗老化的聚全氟乙烯(F46),因而具有耐腐蚀性能良好、抗老化性能高,寿命长,流阻小、流通能力大等优点,特别适用于酸、碱灯强腐蚀性介质场合。

- 特点: 1.耐腐蚀: 阀体内腔及球体均包衬2.5~3mm厚的F46,能耐酸、碱,耐强腐蚀。
 2.采用软密封副,密封性能好。
 3.体积小,重量轻,结构简单,安装维修方便。
 4.流阻小,流通能力大。

Electric O-type lining fluoride cutting ball valve is by NA series of electric actuators and lining of fluorine ball valve. Valve core using lining fluoride cylindrical type through hole sphere combined with soft seal seat.

The product body wall and metal valve components within lining has corrosion resistance, anti-aging of poly full fluoride (F46), thus has good corrosion resistance, ageing resistance is high, long life, small flow resistance, flow capacity big, etc., and especially suitable for acid, alkali lamp strong corrosive medium occasion.

- Features: 1. The corrosion resistance: the body cavity and sphere are packing 2.5~3 mm thick F46, acid, alkali, strong corrosion resistance.
 2. The soft seal seat, sealed performance is good.
 3. Small volume, light weight, simple structure, easy installation and maintenance.
 4. Flow resistance is small, the flow capacity big.

阀体 Body

型式 Type	直通两分式铸造球阀 Through two fraction casting ball valve
公称通径(mm) Nominal diameter	DN15~200mm
公称压力(MPa) Nominal pressure	PN1.0、1.6MPa (ANSI 150Lb)
连接形式 Connection form	法兰连接 Flange connection: JB/T 79-94(ANSI 16.5)
材料 Material	ZG230-450衬F46、ZG1Cr18Ni9Ti衬F46 ZG230-450 lining F46, ZG1Cr18Ni9Ti lining F46
上阀盖 On valve cover	与阀体一起铸造 Together with the valve body casting
填料 Packing	聚四氟乙烯 Teflon
介质温度 Medium temperature	-20~+150℃

执行机构 Actuator

型式 Type	NA系列电子式电动执行机构(可配德国PSQ等执行机构) NA series electronic electric actuator (can match PSQ Germany and actuator)
供电电源 Power supply	220V AC · 50/60HZ
电源接口 Power interface	NPT3/4"
※三相控制 380V Later three phase control 380 v	

阀内组件 Valve components within

阀芯形式 Valve core form	球型阀芯 Ball valve core
流量特性 Flow characteristic	快开特性 Quick opening characteristics
阀座 Seat	聚四氟乙烯 Teflon
材料 Material	ZG230-450衬F46、ZG1Cr18Ni9Ti衬F46 ZG230-450 lining F46, ZG1Cr18Ni9Ti lining F46
阀芯转角 Valve core Angle	90°

阀作用型式 Valve mode of action

电关式或电开式 Electric closed type or electric open

执行机构配置 Actuator configuration

公称通径(mm) Nominal diameter	10	20	25	32	40	50	65	80	100	125	150	200	
执行机构型号 Actuator type	PN10	NA6				NA15			NA50	NA250			
	PN16								NA80				
允许压差MPa Allow differential	等于公称压力 Equal to the nominal pressure												

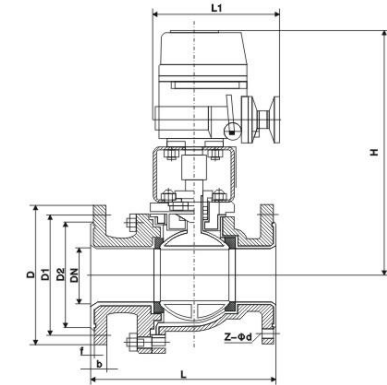

主要连接尺寸及外形尺寸 The main connection dimension and shape dimension

单位 unit : mm

公称通径(mm) Nominal diameter		标准值 Standard						参考值 Reference		
DN (mm)	NPS (Inch)	L	D	D1	D2	f	b	Z-Φd	L1	H
PN1.0(MPa)										
15	1/2	140/130	95	65	45	2	14	4-φ14	231	350
20	3/4	140/130	105	75	55	2	16	4-φ14	231	370
25	1	150/140	115	85	65	2	16	4-φ14	231	375
32	1 1/4	165	135	100	78	2	18	4-φ18	231	385
40	1 1/2	180/165	145	110	85	3	18	4-φ18	231	390
50	2	200/203	160	125	100	3	20	4-φ18	231	435
65	2 1/2	220/222	180	145	120	3	20	4-φ18	261	460
80	3	250/241	195	160	135	3	22	4-φ18	261	465
100	4	280/305	215	180	155	3	22	4-φ18	285	612
125	5	320/356	245	210	185	3	24	4-φ18	285	625
150	6	360/394	280	240	210	3	24	8-φ23	325	700
200	8	457	335	295	265	3	26	8-φ23	325	740
250	10	533	390	350	320	3	28	12-φ23	410	830

公称通径(mm) Nominal diameter		标准值 Standard						参考值 Reference		
DN (mm)	NPS (Inch)	L	D	D1	D2	f	b	Z-Φd	L1	H
PN1.6(MPa)										
15	1/2	140/130	95	65	45	2	14	4-φ14	231	350
20	3/4	140/130	105	75	55	2	16	4-φ14	231	370
25	1	150/140	115	85	65	2	16	4-φ14	231	375
32	1 1/4	165	135	100	78	2	18	4-φ18	231	385
40	1 1/2	180/165	145	110	85	3	18	4-φ18	231	390
50	2	200/203	160	125	100	3	20	4-φ18	231	435
65	2 1/2	220/222	180	145	120	3	20	4-φ18	261	460
80	3	250/241	195	160	135	3	22	4-φ18	261	465
100	4	280/305	215	180	155	3	24	8-φ18	285	612
125	5	320/356	245	210	185	3	20	8-φ18	285	625
150	6	360/394	280	240	210	3	28	8-φ23	325	700
200	8	457	335	295	265	3	30	8-φ23	325	740

气动衬氟O型切断球阀由气动活塞式执行机构和衬氟O型球阀组成，阀芯采用衬氟圆柱型通孔球体和软密封副。

该产品以压缩空气为动力源，借助电磁换向阀对阀门实现二位式控制。

该产品阀体内壁和金属阀内组件衬有耐腐蚀、抗老化的聚全氟乙丙烯(F46)，因而具有耐腐蚀性能良好、抗老化性能高、寿命长、流阻小、流通能力大等优点，特别适用于各行业对酸、碱等强腐蚀性介质场合。

Pneumatic lining fluoride O-type cutting ball valve by pneumatic piston actuators and lining fluoride O type of ball valve, valve core using lining fluoride cylindrical type through hole sphere and soft sealing seat.

This product to compressed air to power sources, with the aid of electromagnetic directional valve to the valve to realize two position control.

The product body wall and metal valve components within lining has corrosion resistance, anti-aging of fep(F46), thus has good corrosion resistance, ageing resistance, long service life, high resistance to flow small, circulation capacity etc, and especially suitable for various industries to acid, alkali and strong corrosive medium occasion.

特点

- 1、耐腐蚀：阀体内腔及阀内组件均包衬2.5~3mm厚的F46，能耐酸、碱，耐腐蚀。
- 2、采用软密封副，密封性能好。
- 3、体积小，重量轻，结构简单，安装维修方便。
- 4、流阻小，流通能力大。

Characteristics

- 1、Corrosion resistance: the body cavity and valve components within all packing the F46, can resist acid, alkali, strong corrosion resistance.
- 2、The soft seal seat, sealed performance is good.
- 3、Small volume, light weight, simple structure, easy installation and maintenance.
- 4、Flow resistance is small, the flow capacity big.

阀体 Body

型式 Type	直通两分式铸造球阀 Through two fraction casting ball valve
公称直径(mm) Nominal diameter	DN15~300mm
公称压力(MPa) Nominal pressure	PN1.0、1.6MPa(ANSI 150Lb)
连接形式 Connection form	法兰连接 Flange connection: JB/T 79~94(ANSI 16.5)
材料 Material	ZG230-450衬F46、ZG1Cr18Ni9Ti衬F46 ZG230-450 lining F46, ZG1Cr18Ni9Ti lining F46
上阀盖 On valve cover	与阀体一起铸造 Together with the valve body casting
填料 Packing	聚四氟乙烯 Teflon
介质温度 Medium temperature	-20~+150℃

阀内组件 Valve components within

阀芯形式 Valve core form	球型阀芯 Ball valve core
流量特性 Flow characteristic	快开特性 Quick opening characteristic
阀座 Seat	聚四氟乙烯 Teflon
材料 Material	ZG230-450衬F46、ZG1Cr18Ni9Ti衬F46 ZG230-450 lining F46, ZG1Cr18Ni9Ti lining F46
阀芯转角 Valve core Angle	90°

执行机构

型单作用气动活塞执行机构(带弹簧复位)GTX
双作用气动活塞式执行机构GTD

供气压力

0.4~0.7MPa

气源接口

1/4NPT

附件(根据要求配置)

电磁阀，空气过滤减压阀，手轮机构，限位开关，限位变送器，气动加速器，保位阀，其它。

Actuator

Type single acting pneumatic piston actuator (with spring reset) GTX
Double-acting pneumatic piston type actuator GTD

Gas supply pressure

0.4~0.7MPa

Air interface

1/4NPT

Accessories (according to requirements configuration)

Electromagnetic valve, air filtration pressure reducing valve, the handwheel institutions, limit switch, Valve position transmitter, pneumatic accelerator, protect a valve, and other.

额定流量系数KV、额定行程 The rated flow coefficient KV, rated stroke

公称直径(mm) Nominal diameter	15	20	25	32	40	50	65	80	100	125	150	200	250	300
额定流量系数KV Rated flow coefficient	21	38	72	112	170	273	384	512	940	1452	2222	3589	5128	7359
额定行程 Rated stroke	90°													
泄漏量 leakage	VI级 VI level													

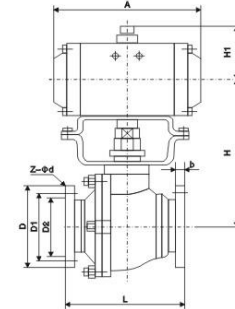

阀与执行机构标准组配 Valve and actuator standard matched

(1)双作用执行机构，阀座材料：聚四氟乙烯 Double acting actuators, the seat material: teflon

PN1.0 PN1.6MPa

公称直径(mm) Nominal diameter	15	20	25	32	40	50	65	80	100	125	150	200	250	300
执行机构型号GTD- Actuator type	63				75		92	118	143	143 (160)	210			
动作时间(S) Action time	1				1.5		2		5					
手轮机构 Wheel mechanism	PWHJ38										PWHJ54			

(2)单作用执行机构，阀座材料：聚四氟乙烯 Single acting actuators, the seat material: teflon

PN1.0 PN1.6MPa

公称直径(mm) Nominal diameter	15	20	25	32	40	50	65	80	100	125	150	200	250	300
执行机构型号GTD- Actuator type	63 S8	75 S8	92 S8	110 S8		127 S10	160 S10	190 S9	210 S10	255* S10	255 S10	255* S10		
动作时间(S) Action time	2.5	3	4		5	8	10	12	26					
手轮机构 Wheel mechanism	PWHJ38						PWHJ54		PWHJ80					

外形尺寸 Physical size

单位 Unit : mm

公称直径(mm) Nominal diameter	L	D	D1	D2	b	Z-φD	H	H1	A	重量kg Weight
15	130	95	65	45	14	4-φ14	150	54	177	7
20	130	105	75	55	16	4-φ14	150			7.8
25	140	115	85	65	16	4-φ14	174			11
32	165	135	100	78	18	4-φ18	174			15
40	165	145	110	85	18	4-φ18	208	80	216	22
50	203	160	125	100	20	4-φ18	237			31
65	222	180	145	120	20	4-φ18	285			36
80	241	195	160	135	22	4-φ18	302			51
100	305	215	100	155	22	8-φ18	324	125	290	84
125	356	245	210	185	24	8-φ18	450			110
150	394	280	240	210	24	8-φ23	480			150
200	457	335	295	265	26	8-φ23	526			230

概述

气动蝶阀是我公司新开发的长寿命节能型蝶阀。蝶阀采用三维偏心原理设计，弹性密封和硬软多层次密封兼容的加工新工艺，使蝶阀在运行工作时密封可靠，可达到气密封无泄漏，采用偏心设计延长蝶阀使用寿命。气动执行机构采用曲臂转换结构，具有输出力矩大、体积小、性能稳定可靠等特点。同阀门定位器或电磁阀配套使用可实现比例调节或开关控制，适用于气体、固体颗粒和液体等介质。可广泛应用于造纸、石化、化工、冶金、电力、环保、石油、轻工、楼宇自动化等工业部门的自动化控制系统中。

产品符合GB/T4213-1992。

Overview

Pneumatic butterfly valve is our newly developed long life energy-saving butterfly valve. Butterfly valve using three dimensional eccentric principle design, elastic seal and hard and soft multi-layer seal compatible processing new techniques, so that the butterfly valve in the operation work reliable sealing, can achieve without leakage gas seal, can reach to gas seal no leakage, using eccentric design extend valve life. Pneumatic actuators using crank arm conversion structure, has the output torque, volume fine small, stable performance, reliability, etc. With the valve positioner or electromagnetic valve supporting the use can realize proportional control or switch control, suitable for gas, solid and liquid, and other media. Can be widely used in papermaking, petrochemical industry, chemical industry, metallurgy, electric power, environmental protection, petroleum, light industry, building automation, and other industrial department of automation control system.

Products comply with GB/T4213-1992.

主要技术参数和性能指标 The main technical parameters and performance index

气动调节切断蝶阀的系列参数 Pneumatic control cutting butterfly valve series parameters

公称直径(mm) Nominal diameter	50	65	80	100	125	150	200	250	300	350	400	450	500	600	700	800
额定流量系数Kv Rated flow coefficient	95	175	270	375	740	1400	2100	3250	4680	6200	8100	11000	15800	21000	29000	38000
最大转角(α°) Maximum Angle	90°															
工作气源压力(MPa) Working air pressure	0.4~0.8															
工作温度范围(°C) Operating temperature range	-40~250															
输入信号 Input signal	(电信号: 4-20mA□dc)220VAC、24VDC (Electrical signals: 4-20mA□dc)220VAC、24VDC															
公称压力(MPa) Nominal pressure	1.0、1.6															
配用气接管 Gas over with	φ8×1(G1/8)			φ8×1.5(G1/4)						φ12×2(G3/8)						
连接形式及标准 Connection form and standard	对夹式、按JB81-94 wafer JB81-94															
阀体材料 Body material	304、316、316L或ZG25															
阀芯材料 Valve core material	304、316、316L															
阀座材料 Seat materials	316、F4															

气动蝶阀流量特性等百分比特性：曲线图如下

Pneumatic butterfly valve flow characteristics of percentage characteristics: diagram below

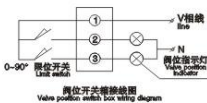
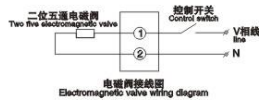
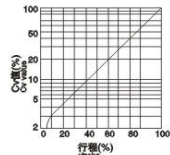

配定位器性

基本误差: ≤±1.5% 回差: ≤1.5% 死差: ≤0.6%

耗气量: ≤900l/n(标准状态)

Match locator performance

Basic error: ≤±1.5% return difference: ≤1.5% die poor: ≤0.6%

Gas consumption: ≤900l/n (standard state)

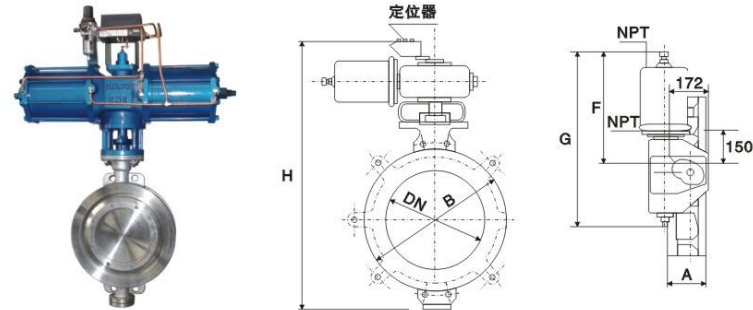

安装与维护

1. 安装蝶阀时，应注意阀体上的流向标志，以免流通方向错误，影响使用。
2. 蝶阀使用前应确认阀全开的前提下对管道进行冲洗，以免有焊渣等杂物刮伤密封面。
3. 蝶阀一般设置旁通管路，在检修或更换蝶阀时，可使用旁通管路使用流程照常进行。
4. 气动蝶阀可在水平180°范围内竖卧安装，切勿将气动执行器朝下倒装。
5. 定位器或电磁阀高度详见说明书。
6. 气动执行器曲臂为方头结构，可用手动装置使用，故障时卸掉气源管直接用手动扳手即可实现手动操作。
7. 使用过程中如发现填料函泄漏，紧固一下压盖螺栓即可解决。

Installation and maintenance

1. Install butterfly valve, should pay attention to the flow of the body signs, in order to avoid circulation direction error, the influence is used.
2. Butterfly valve before use shall confirm the valve fully open premise to conduit rinse, lest have welding slag etc sundry scratches sealing surface.
3. Butterfly valve usually set bypass line, in the repair or replacement butterfly valve, can use bypass line use process went on as usual.
4. Pneumatic butterfly valve can be in level 180° range vertical lie installation, never will pneumatic actuators down inversion.
5. Locator or electromagnetic valve height see instructions.
6. Pneumatic actuators crank arm for coach structure, useable hand gear use, failure uninstalled air tube directly with manual wrench can real reason manual operation.
7. Use process such as the discovery of gland leakage, securing a press cover bolt can solve.

外形尺寸 Physical size

DN	代号 code	A 阀体厚度 Body thickness	B	G	F	H
50		43	100	350	245	420
65		46	118	350	245	453
80		49	131	385	270	488
100		56	158	385	270	545
125		64	180	385	270	578
150		70	216	445	305	665
200		71	268	550	375	690
250		76	326	550	375	780
300		83	370	675	455	950
350		92	430	820	560	995
400		102	480	820	560	1115
450		120	537	1010	690	1200
500		130	690	1010	690	1200
600		154	690	1010	690	1200
700						
800						

安装与维护

1. 产品选型详见说明编制
2. 工作压力及压差MPa
3. 工作温度℃
4. 附件

Installation and maintenance

1. Product selection see that prepare
2. Working pressure and differential pressure MPa
3. Working temperature ℃
4. Accessories



ZSPQ型气动活塞切断阀 ZSPQ type pneumatic piston cut-off valve

概述

ZSPQ气动活塞切断阀由切断机构与气动活塞执行机构组成。切断机构采用直通单座形式，DN20阀芯为单导向，DN25-200阀芯为双导向，具有结构简单，操作方便，使用可靠，快速开闭等特点。主要应用于无杂质、无颗粒的液体、气体介质，要求快速严密关闭，快速放空的自动控制系统中。

产品符合GB/T4213-1992。

Overview

ZSPQPneumatic piston cut-off valve by cutting mechanism and pneumatic piston actuator component. Cutting mechanism using through single block form, DN20 Valve core for single orientation, DN25-200 Valve core for double guide, Has the features of simple structure, convenient operation, use, reliable and fast open closed etc. Mainly used in without impurities, no particles of liquid, gas medium for quick close close, Rapid emptying of the automatic control system.

The product conforms to the GB/T4213-1992.

主要技术参数和性能指标 The main technical parameters and performance index

切断机构主要技术参数 Cutting mechanism main technical parameters

公称口径(mm) Nominal diameter	20	25	32	40	50	65	80	100	125	150	200
阀座直径(mm) Seat diameter	26	43	43	52	62	79	94	115	140	166	216
额定流量系数Kv Rated flow coefficient	6.5	10	15	25	40	65	100	150	260	350	540
公称压力(MPa) Nominal pressure	4.0 6.4										
行程L(mm) stroke	16		25		40		60				
介质温度℃ Medium temperature	两位快开式 Two quick open										
流量特性 Characteristics	-20-150(常温)、-20-450(中温型)、-20-550(高温)、-250--60(低温) - 20 - 150 (room temperature), - 20 - 450 (medium temperature type), - 20 - 550 (high temperature), - 250 - 60 (low temperature) -										
配执行机构 Match actuator	ZSD-2		ZSD-3		ZSD-5		ZSD-7				
法兰尺寸 Flange size	按JB79-59										
法兰型式 Flange type	法兰密封型式按JB77中凹式 Flange seal type according to JB77 concave type										
阀体材质 Body material	ZG230-450、ZG1Cr18Ni9Ti、ZG1Cr18Ni12Mo2Ti、CF8M (254℃)										

活塞执行机构主要技术参数 Piston executing agency main technical parameters

型号 Type	ZSD-2	ZSD-3	ZSD-5	ZSD-7
活塞直径mm Piston diameter	150	200	300	400
有效面积cm ² Effective area	175	305	700	1245
行程(mm) stroke	10;16	25	40	60
进气孔螺纹 Inlet hole thread	M16×1.5	M20×1.5		M24×2
最大输出力N Maximum output force	7200	21280	29300	52000
操作气源压力KPa Operating air pressure	500			

ZSPQ型气动活塞切断阀 ZSPQ type pneumatic piston cut-off valve

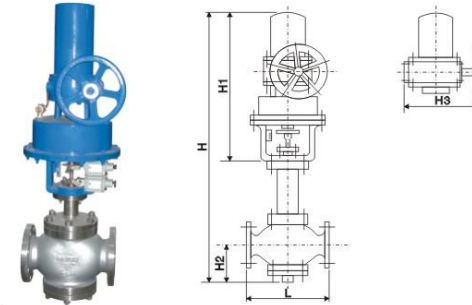

性能指标 Performance index

公称口径(mm) Nominal diameter	20	25	32	40	50	65	80	100	125	150	200
泄漏量 ml/min leakage	软密封 Soft seal	0									
	硬密封 Hard seal	≤1	≤3		≤5			≤7	≤9		
切断时间S Break time	1-2					2-4					
额定行程偏差% Rated stroke deviation	±1.5										

注：泄漏量用水做试验。 Note: leakage water do experiment.

允许压差 Allow differential pressure

公称口径(mm) Nominal diameter	20	25	32	40	50	65	80	100	125	150	200
允许压差MPa Allow differential pressure	4.0					4.0	4.0	2.8	3.5	2.4	
						(2.5)	(1.7)	(1.0)	(1.1)	(0.8)	(1.6)

注：括号内数据为气关式阀允许压差。 Note: data in bracket for gas close type valve allows pressure difference.

可配附件 Can match accessories

手轮、电磁阀、回讯器(或行程开关)
The handwheel, electromagnetic valve, back - device (or travel switch)

外形尺寸 Physical size

常温型气动活塞切断阀外形尺寸 Cold type pneumatic piston cut-off valve external dimensions

公称口径 (mm) Nominal diameter	L	H ₂	带手轮 take the handwheel			不带手轮 Don't take the handwheel			
			H	H ₁	H ₃	重量kg weight	H	H ₁	重量kg weight
20	180	53	609	447	222	39	574	359	26
25	180	111	621	447	222	46	644	359	33
32	210	117	627	447	222	48	656	359	35
40	230	131	754	570	280	85	778	463	61
50	255	146	769	570	280	89	808	463	65
65	285	181	950	706	389	135	969	542	97
80	310	190	957	706	389	143	983	542	99
100	355	194	961	706	389	163	991	542	109
125	425	256	1332	1022	389	305	1305	739	218
150	460	266	1342	1022	389	331	1325	739	244
200	560	289	1370	1022	389	445	1376	739	358

ZSPQ型气动活塞切断阀 ZSPQ type pneumatic piston cut-off valve

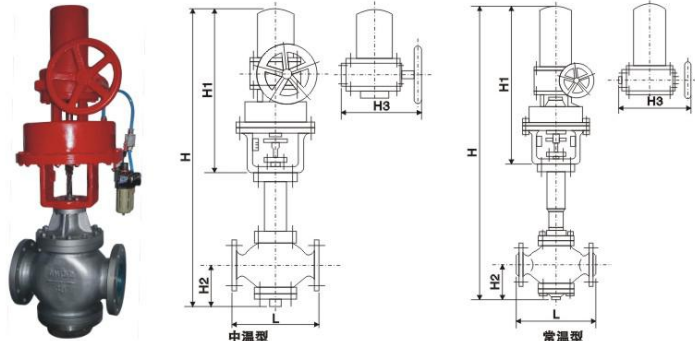

中温型气动活塞切断阀外形尺寸 Medium temperature type pneumatic piston cut-off valve external dimensions

公称口径 (mm) Nominal diameter	L	H ₂	带手轮 take the handwheel				不带手轮 Don't take the handwheel		
			H	H ₁	H ₃	重量kg weight	H	H ₁	重量kg weight
20	180	53	760	447	222	43	725	359	30
25	180	111	772	447	222	52	795	359	39
32	210	117	778	447	222	54	807	359	41
40	230	131	905	570	280	90	929	463	66
50	255	146	920	570	280	95	969	463	71
65	285	181	1115	706	389	145	1132	542	101
80	310	190	1120	706	389	155	1146	542	111
100	355	194	1124	706	389	172	1154	542	128
125	425	256	1547	1022	389	327	1520	739	240
150	460	266	1557	1022	389	356	1540	739	269
200	560	289	1585	1022	389	464	1591	739	377

常温型气动活塞切断阀外形尺寸 Cold type pneumatic piston cut-off valve external dimensions

公称口径 (mm) Nominal diameter	L	H ₂	带手轮 take the handwheel			不带手轮 Don't take the handwheel	
			H	H ₁	H ₃	H	H ₁
20	180	53	965	447	222	930	359
25	180	111	977	447	222	1000	359
32	210	117	983	447	222	1012	359
40	230	131	1111	570	280	1135	463
50	255	146	1126	570	280	1165	463
65	285	181	1369	649	280	1443	542
80	310	190	1368	649	280	1451	542
100	355	194	1372	649	280	1459	542
125	425	256	1772	872	378	1895	739
150	460	266	1782	872	378	1915	739
200	560	289	1805	872	378	1961	739

ZSPQ型气动活塞切断阀 ZSPQ type pneumatic piston cut-off valve

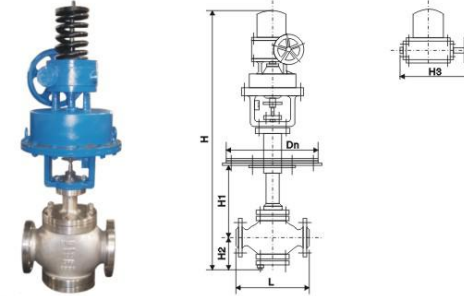

低温型气动活塞切断阀外形尺寸 Low temperature type pneumatic piston cut-off valve external dimensions

公称口径 (mm) Nominal diameter	L	H ₂	H ₃	>-101℃				>-196℃				>-253℃			
				带手轮 take the handwheel		不带手轮 Don't take the handwheel		带手轮 take the handwheel		不带手轮 Don't take the handwheel		带手轮 take the handwheel		不带手轮 Don't take the handwheel	
				H ₁	H	H ₁	H	H ₁	H	H ₁	H	H ₁	H	H ₁	H
20	180	53	222	500	1074	500	986	700	1274	700	1186	900	1474	900	1386
25	190	111	222	500	1070	500	982	700	1270	700	1182	900	1470	900	1380
32	210	117	222	500	1076	500	988	700	1276	700	1188	900	1476	900	1388
40	230	131	280	500	1179	500	1072	700	1379	700	1272	900	1579	900	1472
50	255	146	280	500	1189	500	1082	700	1389	700	1282	900	1589	900	1482
65	285	181	280	600	1373	600	1268	800	1573	800	1468	1000	1773	1000	1668
80	310	190	280	600	1375	600	1268	800	1575	800	1468	1000	1775	1000	1668
100	355	194	280	600	1375	600	1268	800	1575	800	1468	1000	1775	1000	1668
125	425	256	378	700	1686	700	1553	900	1886	900	1753	1100	2086	1100	1953
150	460	266	378	700	1686	700	1553	900	1886	900	1753	1100	2086	1100	1953
200	560	289	378	700	1683	700	1560	900	1883	900	1760	1100	2083	1100	1960

主要零件材料 The major parts material

零件名称 Part name	材料 material
阀体、阀盖 Valve body, valve cover	ZG230-450, ZG1Cr18Ni9Ti, CF8, CF8M
阀芯、阀杆 Valve core, the valve stem	2Cr13, 25CrMo1VA, 1Cr18Ni9, 17-4PH或17-7H(低温)
密封填料 packing	V型聚四氟乙烯、柔性石墨、柔性石墨+316SS碳素钢 V type teflon, flexible graphite, flexible graphite + 316 ss carbon steel
密封垫 gasket	1Cr18Ni9夹石棉板、石墨缠绕式、包覆式 1 cr18ni9 clamp asbestos board, graphite spiral wound, coating type
蜗杆 worm	45
O型密封圈 Type O ring	耐油橡胶 Oil resistant rubber
压缩弹簧 Compression spring	60Si2Mn
支架 support	QT420-10, WCB, CF8
蜗轮箱、蜗轮、气缸、轴承盖、活塞 Worm gear box, worm gear, cylinder, bearing cover, piston	HT200
推杆 Push rod	2Cr13

订货须知

订货时请填写《规格书》或注明以下内容:

- 1、产品型号
- 2、公称口径
- 3、流量系数
- 4、公称压力
- 5、阀体材料
- 6、使用温度
- 7、使用介质
- 8、阀作用方式(气开式或气关式)
- 9、是否有其它特殊要求

Order instructions

When ordering, please fill in 《specification》 or indicate the following contents:

1. product model
2. nominal diameter
3. flow coefficient
4. nominal pressure
5. the valve body material
6. using temperature
7. use medium
8. valve mode of action (gas open or gas close type)
9. of whether any other special requirements

概述

ZQGP型气动快速切断阀由国内首次推出的气动多弹簧活塞执行机构和低流阻、双重密封结构的切断阀组成。执行机构动作速度快、推力大、有自复位功能、带手操机构；阀体流通顺畅、流量系数大、阀芯阀座有弹性和刚性串级双重密封。新颖独特的结构使本产品成为一类快速动作严密切断、安全可靠的高性能新型切断阀。

本产品性能优良、规格齐全，还有形体小、重量轻等优点，它能满足化工、石油、冶金和其它工业部门生产过程中自动快速排放和紧急切断的操作要求，适用于生产过程和设备的安全保护系统，也适用于一般的两位控制和开关操作场合。

Overview

ZQGP type pneumatic rapid cut-off valve by the domestic first launched more than the pneumatic spring piston actuator and low flow resistance, double seal structure of the cut-off valve composition. actuator movement speed, thrust, have since the reset function, appliance with operating mechanism; Body flows unobstructed, flow coefficient, valve core seat flexible and rigid cascade double seal. The new Clever unique structure makes this product as a kind of quick motion close cut off, safe and reliable performance of the new type of cut-off valve.

The products of excellent performance, complete specifications, and the form of small, light weight, etc., and it can satisfy the chemical, oil, metallurgical and other industrial department production process automatic rapid emissions and emergency cut-off operation requirements, applicable to the production process and equipment safety protection system, is also applicable to the general two control and switch operation occasion.

规格与技术参数 Specifications and technical parameters

公称压力(MPa) Nominal pressure	1.6、6.4							
公称口径(mm) Nominal diameter	25	40	50	65	80	100	150	200
额定流量系数Kv Rated flow coefficient	10	25	40	63	100	160	400	630
额定行程mm Rated stroke	10	16			30		60	
气缸有效面积Cm ² Cylinder effective area	180	380			700		1400	
全行程时间S Full travel time	≤1			≤1.5			≤2	
允许压差MPa Allow differential pressure	6.4			4.8	3.1	2.7	1.6	
泄漏量 leakage	硬密封: 1 × 10 ⁻⁷ 阀额定容量 Hard seal: 1 × 10 ⁻⁷ valve rated capacity							
	软密封: VI级(GB/T4213) Soft seal: VI level (GB/T4213)							
操作压力KPa Operating pressure	500							
工作温度℃ Working temperature	-40~+250, -40~+450, -40~+180(软密封 Soft seal)							
环境温度℃ Environment temperature	-40 ~ +70							

主要零件材料 The major parts material

零件名称 Zero a name	材料 Wood material
阀体、阀盖 Valve body, valve cover	ZG230-450, ZG1Cr18Ni9, ZG0Cr18Ni12Mo2Ti
阀芯、阀座 Valve core and valve seat	1Cr18Ni9, 0Cr18Ni12Mo2Ti, (密封面堆焊史太立合金 Sealing surface overlaying history too made alloy)
阀座圈 Valve seat	0Cr18Ni12Mo2Ti, (聚四氟乙烯 Teflon)
填料 Fill material	聚四氟乙烯, 柔性石墨 Teflon, flexible graphite

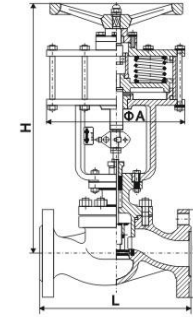

(a) DN25 - 100

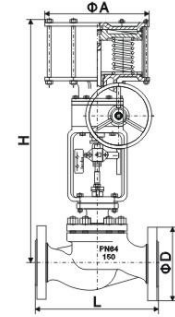

(b) DN150-200

外形尺寸及重量 Physical size and weight

DN	H	Hg	ΦA	ΦD		L		重量 Weight (kg)
				PN16	PN64	PN16	PN64	
25	410	580	196	115	135	184	210	24
40	514	684	266	150	165	222	251	43
50	520	690	266	165	175	254	286	48
65	694	904	348	185	200	276	311	77
80	696	906	348	200	210	298	337	89
100	709	919	348	220	250	352	394	110
150	1186	1446	486	285	340	451	508	320
200	1208	1468	486	340	405	600	650	394

注: H—工作温度-40~250℃, Hg—工作温度-40~450℃(伸长型阀盖)。
Note: H—working temperature -40~250℃, Hg—working temperature -40~450℃ (elongation type valve cover).

※ 技术参数如有更改, 恕不另行通知。
※ Technical parameters such as are subject to change without prior notice.

订货须知:

订货时请注明:

1. 产品型号
2. 公称口径
3. 介质名称及工作温度
4. 阀切断压差
5. 阀的开关方式(气开式或气关式)
6. 阀体材料
7. 附件

Ordering instructions:

When ordering, please specify:

1. The product model
2. Nominal diameter
3. Medium name and working temperature
4. Valve cut off pressure difference
5. Valve switch mode (gas open or gas close type)
6. The valve body material
7. Accessories

概述

ZQGP型气动快速切断阀由国内首次推出的气动多弹簧活塞执行机构和低流阻、双重密封结构的切断阀组成。执行机构动作速度快、推力大、有自复位功能、带手操机构；阀体流通顺畅、流量系数大、阀芯阀座有弹性和刚性串级双重密封。新颖独特的结构使本产品成为一类快速动作严密切断、安全可靠的高性能新型切断阀。

本产品性能优良、规格齐全，还有形体小、重量轻等优点，它能满足化工、石油、冶金和其它工业部门生产过程中自动快速排放和紧急切断的操作要求，适用于生产过程和设备的安全保护系统，也适用于一般的两位控制和开关操作场合。

Overview

ZQGP type pneumatic rapid cut-off valve by the domestic first launched more than the pneumatic spring piston actuator and low flow resistance, double seal structure of the cut-off valve composition. actuator movement speed, thrust, have since the reset function, appliance with operating mechanism; Body flows unobstructed, flow coefficient, valve core seat flexible and rigid cascade double seal. The new Clever unique structure makes this product as a kind of quick motion close cut off, safe and reliable performance of the new type of cut-off valve.

The products of excellent performance, complete specifications, and the form of small, light weight, etc., and it can satisfy the chemical, oil, metallurgical and other industrial department production process automatic rapid emissions and emergency cut-off operation requirements, applicable to the production process and equipment safety protection system, is also applicable to the general two control and switch operation occasion.

规格与技术参数 Specifications and technical parameters

公称压力(MPa) Nominal pressure	1.6、6.4							
公称口径(mm) Nominal diameter	25	40	50	65	80	100	150	200
额定流量系数Kv Rated flow coefficient	10	25	40	63	100	160	400	630
额定行程mm Rated stroke	10	16			30		60	
气缸有效面积Cm ² Cylinder effective area	180	380			700		1400	
全行程时间S Full travel time	≤1			≤1.5			≤2	
允许压差MPa Allow differential pressure	6.4			4.8	3.1	2.7	1.6	
泄漏量 leakage	硬密封: 1 × 10 ⁻⁷ 阀额定容量 Hard seal: 1 × 10 ⁻⁷ valve rated capacity							
	软密封: VI级(GB/T4213) Soft seal: VI level (GB/T4213)							
操作压力KPa Operating pressure	500							
工作温度℃ Working temperature	-40~+250, -40~+450, -40~+180(软密封 Soft seal)							
环境温度℃ Environment temperature	-40 ~ +70							

主要零件材料 The major parts material

零件名称 Zero a name	材料 Wood material
阀体、阀盖 Valve body, valve cover	ZG230-450, ZG1Cr18Ni9, ZG0Cr18Ni12Mo2Ti
阀芯、阀座 Valve core and valve seat	1Cr18Ni9, 0Cr18Ni12Mo2Ti, (密封面堆焊史太立合金 Sealing surface overlaying history too made alloy)
阀座圈 Valve seat	0Cr18Ni12Mo2Ti, (聚四氟乙烯 Teflon)
填料 Fill material	聚四氟乙烯, 柔性石墨 Teflon, flexible graphite

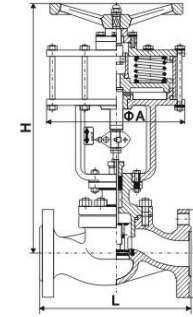

(a) DN25-100

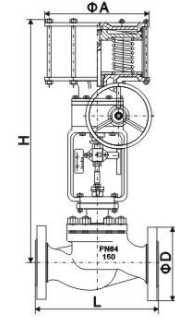

(b) DN150-200

外形尺寸及重量 Physical size and weight

DN	H	Hg	ΦA	ΦD		L		重量 Weight (kg)
				PN16	PN64	PN16	PN64	
25	410	580	196	115	135	184	210	24
40	514	684	266	150	165	222	251	43
50	520	690	266	165	175	254	286	48
65	694	904	348	185	200	276	311	77
80	696	906	348	200	210	298	337	89
100	709	919	348	220	250	352	394	110
150	1186	1446	486	285	340	451	508	320
200	1208	1468	486	340	405	600	650	394

注: H—工作温度-40~250℃, Hg—工作温度-40~450℃(伸长型阀盖)。
Note: H—working temperature -40~250℃, Hg—working temperature -40~450℃ (elongation type valve cover).

※ 技术参数如有更改, 恕不另行通知。
※ Technical parameters such as are subject to change without prior notice.

订货须知:

订货时请注明:

1. 产品型号
2. 公称口径
3. 介质名称及工作温度
4. 阀切断压差
5. 阀的开关方式(气开式或气关式)
6. 阀体材料
7. 附件

Ordering instructions:

When ordering, please specify:

1. The product model
2. Nominal diameter
3. Medium name and working temperature
4. Valve cut off pressure difference
5. Valve switch mode (gas open or gas close type)
6. The valve body material
7. Accessories



ZM_BQ(M)气动薄膜切断阀、气动薄膜三通切断阀
ZM_BQ(M)Pneumatic film cut-off valve、pneumatic film tee cut-off valve

概述

气动薄膜切断阀，是气动单元组合仪表中的执行单元。具有结构简单、操作力大、体积小、重量轻、阻流小、容量大、密封性能好、维修方便等优点。广泛应用于石油、化工、冶金、电力、轻纺等生产过程中的自动化控制系统中。
产品符合GT/4213-1992。

Overview

Pneumatic membrane cut-off valve, pneumatic unit combination instrument of execution unit. With simple structure, operating force, shape of small, light weight, small flow resistance, large capacity, good seal performance, easy maintenance, etc. Advantages. Widely used in petroleum, chemical, metallurgy, electric power, textile and other production process automation control system.
The product conforms to the GT / 4213-1992.

主要技术参数 Main technical parameters

公称口径(mm) Nominal diameter		15	20	25	32	40	50	65	80	100	125	150	200
额定流量系数Kv Rated flow coefficient	套筒 Sleeve			11	20	30	48	75	120	190	300	480	760
	单座 Single-seat	5	7	11	20	30	48	75	120	190	300	480	760
	三通 Tee												
额定行程(mm) Rated stroke		8			12			20		25		40	
允许泄漏量 Allow leakage	硬密封(I/h) Hard seal	套筒 5×10^{-6} × 阀额定容量 单座、三通 1.2×10^{-7} × 阀额定容量 Sleeve 5×10^{-6} × valve rated capacity single seat, tee 1.2×10^{-7} × seven by valve rated capacity											
	软密封(ml/min) Soft seal	无 No											
硬密封(°C) Hard seal		-20~+200 -40~+425											
膜片有效面积(cm ²)(薄膜式切断阀) Diaphragm effective area (cm ²) (diaphragm cut-off valve)		100			200			400		600		1000	
公称压力(MPa) Nominal pressure		1.6 6.4											
允许压差(MPa) Allow differential pressure	单座 Single-seat	6.4	6.4	3.8	2.5	2.9	1.8	2.0	1.3	0.83	0.8	0.55	0.52
	套筒 Sleeve	6.4											
信号压力(KPa) Signal pressure		200(薄膜式) 200 (diaphragm)											
阀体 Body		WCB ZG1Cr18Ni9Ti											
阀套套筒 Plug sleeve		1Cr18Ni9Ti 0Cr18Ni12Mo2Ti											
阀芯、阀座 Valve core and valve seat		1Cr18Ni9Ti 0Cr18Ni12Mo2Ti											
填料 Packing		聚四氟乙烯 柔性石墨 Teflon flexible graphite											

标准附件

空气过滤减压阀、电磁阀、阀位回讯器等

Standard accessories

Air filtering pressure relief valve, solenoid valve, valve position back - apparatus, etc



ZM_BQ(M)气动薄膜切断阀、气动薄膜三通切断阀
ZM_BQ(M)Pneumatic film cut-off valve、pneumatic film tee cut-off valve

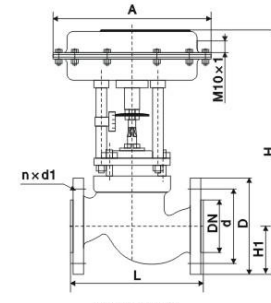

单座切断阀外形图
Single seat cut-off valve outline drawing

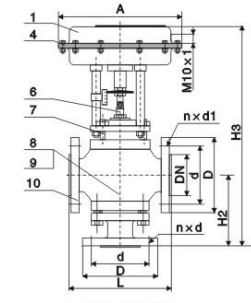

二位三通切断阀外形图
Two tee cut-off valve outline drawing

外形尺寸 Physical size

公称口径(mm) Nominal diameter	15	20	25	32	40	50	65	80	100	125	150	200	
额定流量系数 Rated flow coefficient	5	8	12	17	29	43	70	110	165	275	440	690	
A(mm)		194			230			306			394		394
L (mm)	PN16	495	160	180	200	230	290	310	350	400	480	600	
	PN64	230		260			300	340	380	430	500	650	
D (mm)	PN16	95	105	115	140	150	165	185	200	220	250	285	340
	PN64	105	130	140	155	170	180	205	215	250	295	345	415
H(mm)		325			346	360	369	477	517	540	742	822	877
H ₁ (mm)		50	53	58	70	75	83	93	100	110	125	143	170

公称口径(mm) Nominal diameter	20	25	32	40	50	65	80	100	125	150	200	
额定流量系数 Rated flow coefficient	8	12	17	29	43	70	110	165	275	440	690	
A(mm)		194	194	194	230	230	306	306	306	394	495	495
L (mm)	PN16	150	160	180	200	230	290	310	350	400	480	600
	PN64	230	230	260	260	300	340	380	430	500	550	650
D (mm)	PN16	105	115	140	150	165	185	200	220	250	285	340
	PN64	130	140	155	170	180	205	215	250	295	345	415
H ₂ (mm) PN16		115	121	130	140	153	178	190	200	260	320	360
H ₂ (mm) PN40		125	130	140	150	160	185	200	220	280	320	380
H ₃ (mm)		415	428	448	448	468	551	578	590	886	1008	1120

订货须知

订货时请填写《规格书》或详细注明以下内容：

1. 产品型号
2. 公称口径
3. 公称压力
4. 使用介质
5. 介质温度
6. 阀体、阀芯材料
7. 允许压差
8. 附件

Order instructions

When ordering, please fill in (specification) or specify the following contents:

1. The product model
2. Nominal diameter
3. Nominal pressure
4. Use medium
5. Medium temperature
6. The valve body, valve core material
7. Allow pressure difference
8. Accessories

调节蝶阀系列

Regulating butterfly valve series

ZDLW电子式电动调节蝶阀

ZDLW electronic electric adjustment butterfly valve



概述

ZDLW型电子式电动调节蝶阀，是由3810L电子式电动执行机构和蝶阀调节机构组成，执行机构内有伺服系统，无须另配伺服放大器。具有结构简单、流通能力大、调节精度高等特点。适用于含有悬浮颗粒的流体及浓油、浆状流体的调节和控制，广泛应用于化工、石油、冶金、电站等工业生产过程中。

Overview

ZDLW type electronic electric adjustment butterfly valve, is made of 3810L electronic electric actuators and butterfly valve adjusting mechanism composition, actuator has servo system, without the other match servo amplifier. Has the features of simple structure, flow capacity big, adjustment precision higher characteristic. Suitable for containing suspended particles and fluid thick cloud, slurry fluid regulation and control, which are widely used in chemical, petroleum, metallurgy, power stations, and other industrial production process.

型号、规格 Model, specification

类别 Category	直行程 Straight stroke		角行程 Angle stroke	
	常温型 Cold type	中温型 Medium temperature type	常温型 Cold type	中温型 Medium temperature type
型号 Model	ZDLW-6 $\frac{B}{K}$	ZDLW-6 $\frac{B}{K}$ G	ZDLW-6 $\frac{B}{K}$	ZDLW-6 $\frac{B}{K}$ G
规格 Specifications	DN600-1000		DN50-500	

主要技术参数和性能指标 The main technical parameters and performance index

1.蝶阀调节机构主要技术参数 The butterfly valve adjusting mechanism main technical parameters

公称直径(mm) Nominal diameter	50 80 100 125 150 200 250 300 350 400 450 500 600 700 800 900 1000
公称压力(MPa) Nominal pressure	0.6
介质温度℃ Medium temperature	常温-20-200(铸铁)、-40-250(铸钢)、中温-40-450(铸不锈钢) Cold -20-200 (cast steel), -40-250 (cast steel), medium temperature -40-450 (cast stainless steel)
转角范围 Angle range	0-70°
流量特性 Flow characteristic	近似等百分比 Approximate equal percentage
环境温度℃ Environment temperature	无空间加热器: -10-60; 带空间加热器: -35-60 No space heater: -10-60; With space heater: -35-60
接管法兰 Nozzle flange	按JB78-59对夹式法兰连接 According to the JB78-59 wafer flange connection
阀体材质 Body material	HT200; 35; ZG230-450; 1Cr18Ni9; ZG1Cr18Ni9Ti
阀板材质 Valve plate quality	HT200; 35; ZG230-450; 1Cr18Ni9; ZG1Cr18Ni9Ti

2.3810L直行程电子式电动执行机构主要技术参数 3810 L straight stroke electronic electric actuators main technical parameters

型号 Model	输出力N Output force	速度mm/s Speed	最大行程m Maximum stroke	技术参数 Technical parameters
381LSC-99	10000	2.0	100	电源 Power: AC220V ^{+10%} -15%、50Hz 控制信号 Control signal: 1-5Vd.c. 4-20mAd.c. (信号线用屏蔽线 Signal wire with shielded wire) 开度信号 Opening signal: 4-20mAd.c. 保护等级 Protection level: 相当Quite IP55 防爆标志 Explosion-proof mark: Exd II BT4

3. 3810L角行程电子式电动执行机构技术参数 3810L angular travel electronic electric actuators technical parameters

型号 Model	输出力矩N·m Output torque	动作时间S/90° Action time	转角 Turn Angle	技术参数 Technical parameters
381RSA-02	20	8.5	60°	电源 Power: 220±10% V a.c. 50Hz 驱动电机 Drive motor: 交流可逆电机 Ac reversible motor 输入信号 Input signal: 1-5V d.c 4-20mV d.c (信号线用屏蔽线 Signal wire with shielded wire) 开度信号 Opening signal: 4-20mA d.c 防护等级 Protection level: 相当 IP55 防爆标志 Explosion-proof mark: Exd II BT4
381RSA-05	50	17.0		
381RSB-10	100	18.0		
381RSB-20	200	36.0		
381RSC-30	300	24.0	90°	
381RSC-50	500	42		
381RSC-60	600	48.0		
381RXB-10	100	18.0		
381RXB-20	200	36.0		

4. 性能指标 Performance index

项目 Item		技术指标 Technical performance index	
基本误差% Basic error		±2.5	
回差% Return difference		2.0	
死区% Dead zone		3.0	
始终点偏差% Always point deviation	电开 Electric open	始点 Linitial point	±2.5
		终点 End	±2.5
	电关 Electric shut	始点 Linitial point	±2.5
		终点 End	±2.5
额定流量系数误差% The rated flow coefficient error		±2.5	
允许泄漏量L/h Allow leakage		2×10 ⁻⁴ ×阀的额定容量 2×10 ⁻⁴ ×Valve rated capacity	

5. 额定流量系数Kv The rated flow coefficient

转角 Angle	10°	10°	20°	30°	40°	50°	60°	70°
公称口径(mm) Nominal diameter	50	1.9	7.5	17	30	46	64	85
	80	6.7	15	30	35	92	140	220
	100	10	23	46	85	140	220	340
	125	16	35	70	130	220	340	530
	150	20	50	100	190	320	490	770
	200	40	90	180	340	570	870	1360
	250	60	140	290	530	900	1380	2130
	300	90	200	410	760	1280	1960	3060
	350	130	280	550	1040	1750	2660	4160
	400	180	370	730	1340	2300	4400	5450
	450	200	470	930	1700	2900	3480	6900
	500	250	570	1140	2120	3560	5430	8500
	600	360	820	1630	3050	5140	7840	12200
	700	500	1120	2200	4160	7000	10600	16600
	800	650	1450	2900	5400	9100	13800	21700
	900	810	1839	3726	6885	11583	17658	27540
1000	1000	2270	4600	8500	14300	21800	34000	

6. 允许压差 Allow differential pressure

公称口径 (mm) Nominal diameter	配用执行机构 With actuator													
	381RSA-05		381RSB-10 381RXB-10		381RSB-20 381RXB-20		381RSC-30		381RSC-50		381RSC-60		381LSC-99	
	0°	70°	0°	70°	0°	70°	0°	70°	0°	70°	0°	70°	0°	70°
50	0.6	0.6												
80	0.6	0.6												
100	0.6	0.315												
125	0.6	0.16	0.6	0.325	0.6	0.6								
150	0.6	0.094	0.6	0.189	0.6	0.378								
200	0.6	0.039	0.6	0.079	0.6	0.158								
250			0.6	0.041	0.6	0.082	0.6	0.124						
300			0.6	0.023	0.6	0.047	0.6	0.07						
350			0.6	0.015	0.6	0.03	0.6	0.045						
400							0.6	0.03	0.6	0.05	0.6	0.060		
450							0.6	0.021	0.6	0.035	0.6	0.042		
500							0.6	0.015	0.6	0.026	0.6	0.031		
600													0.6	0.015
700													0.542	0.009
800													0.337	0.006
900													0.259	0.004
1000													0.18	0.003

注: 根据现场使用条件, 可配防爆型执行机构。
Note: according to the conditions of use, can match explosion-proof type actuator.

外形尺寸 Physical size

1. ZDLW DN50-500外形尺寸 ZDLW 50-500 external dimensions

公称口径 (mm) Nominal diameter	D	D1	L1	L2			D2			H			n-d
				配A型 Match A type	配B型 Match B type	配C型 Match C type	配A型 Match A type	配B型 Match B type	配C型 Match C type	配A型 Match A type	配B型 Match B type	配C型 Match C type	
50		110	92	355									4-14
80	125	150	92	355									4-18
100	145	175	102	385									4-18
125	175	200	117	384	429		225			200			8-18
150	200	225	130	397	442								8-18
200	255	280	172	437	482								8-18
250	310	335	197		511	561							12-18
300	362	395	227		536	586							12-23
350	412	445	252		561	611							12-26
400	462	495	296			656			335				16-23
450	518	550	321			679							16-23
500	568	600	346			704							16-23

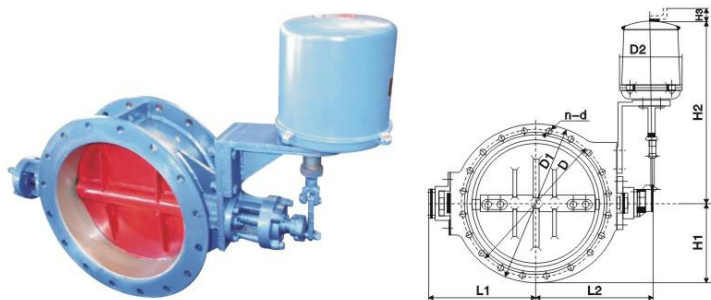

2. ZDLW DN600-1000外形尺寸 ZDLW DN600-1000 external dimensions

公称通径(mm) Nominal diameter	L1	L2	D	D1	D2	H1	H2	H3	n-d
600	480	585	705	755	310	377.5	790		20-25
700	590	635	810	860		430	790		24-25
800	595	695	920	975		487.5	790		24-30
900	685	790	1020	1075		537.5	805		24-30
1000	735	830	1120	1175		587.5	805		24-30

主要零件材料及推荐使用温度范围 The major parts material and the recommended temperature range

零件名称 Part name	材料 Material	温度范围℃ Temperature range
阀体、阀板 Valve body, valve plate	HT200	-20~200
	35	-40~450
	ZG230-450	
	1Cr18Ni9	
	ZG1Cr18Ni9Ti	-40~550
ZG0Cr18Ni12Mo2Ti		

订货须知

订货时应详细说明以下条件:

- 1.产品型号
- 2.工作温度范围
- 3.公称通径和额定流量系数Kv
- 4.执行器内是否带空间加热器,是否带过载保护装置
- 5.阀前压力,阀后压力,公称压力
- 6.阀体、阀板材料
- 7.是否有其它要求

Order instructions

When you place an order should detail the following conditions:

1. The product model
2. Operating temperature range
3. Nominal diameter and the rated flow coefficient Kv
4. Within the actuator whether or not to bring a space heater, whether or not to bring a overload protection device
5. Valve pressure before and after valve pressure and nominal pressure
6. The valve body, valve plate material
7. If there is other requirements

概述

ZAJW型电动调节蝶阀由DKJ角行程电动执行机构和蝶阀组成, 经与电动单元组合仪表配合使用。具有结构简单、口径大、重量轻、操作方便等优点。广泛应用于冶金、电站、石油、化工等部门。

产品符合JB/T7387-1994。

Overview

ZAJW type electric adjustment butterfly valve by DKJ Angle stroke electric actuators and butterfly valve composition, after classics and electric unit combination instrument used together. with Have simple structure, size, light weight and easy to operate, and other advantages. Widely used in metallurgy, power, petroleum, chemical industry and other departments.

Product complies with JB/T7387-1994.

主要技术参数和性能指标 The main technical parameters and performance index

1. 调节机构主要技术参数 Regulatory agency main technical parameters

公称通径(mm) Nominal diameter	50	80	100	125	150	200	250	300	350	400	450	500	600	700	800	1000	1200	1400	1600	1800	1900	2000	
额定流量系数Kv Rated flow coefficient	85	225	340	500	770	1360	2130	3060	4160	5450	6900	8500	12200	18600	21700	34000	49000	66600	87000	110000	23000	136000	
执行机构型号 Actuator type	DKJ																						
公称压力(MPa) Nominal pressure	0.6																						
介质温度℃ Medium temperature	常温-15~+200(铸铁)、-29~+250(铸钢)、中温-40~+450(铸不锈钢) Cold-15~+200 (iron), -29~+250 (cast steel), medium temperature-40~+450 (cast stainless steel)																						
转角范围 Angle range	平行阀板0~70°, 倾斜阀板0~60° Parallel valve plate 0~70°, inclined valve plate 0~60°																						
流量特性 Flow characteristic	近似等百分比 Approximate equal percentage																						
接管法兰 Nozzle flange	按JB78中对夹式法兰连接 According to the JB78 wafer flange connection																						
动作时间S Action time	25																						
阀体材质 Body material	HT200、35、WCB、1Cr18Ni9、ZG1Cr18Ni9Ti、ZG1Cr18Ni12Mo2Ti、CF8、CF8M																						

2. 执行机构主要技术参数 Actuator main technical parameters

型号 Model	DJK-110	DJK-210	DJK-310	DJK-410	DJK-510
输入信号 Input signal	DC0~10mA DC4~20mA				
输入电阻 Q Input resistance	200				
输出转角 Output Angle	0~90°				
输出转矩 N.m Output torque	40	100	250	600	1600
电源 Power	220V 50Hz				

3. 主要技术性能指标 The main technical performance index

项目 Item mesh	指标值 Index value
基本误差% Basic error	±8.0
回差% Return difference	≤6.0
死区% Dead zone	≤5.0
额定行程偏差% Rated stroke deviation	±4.0
允许泄漏量 L/h Allow leakage	平行阀板: $2 \times 10^{-4} \times$ 阀额定容量, 倾斜阀板: $5 \times 10^{-4} \times$ 阀额定容量 Parallel valve plate: $2 \times 10^{-4} \times$ valve rated capacity, inclined valve plate: $5 \times 10^{-4} \times$ valve rated capacity

4. 允许压差与执行机构选型 Allow pressure difference and actuator selection

公称口径 (mm) Nominal diameter	配用执行机构 With actuator											
	DKJ-110		DKJ-210		DKJ-310		DKJ-410		DKJ-510		DKJ-610	
	0°	70°	0°	70°	0°	70°	0°	70°	0°	70°	0°	70°
50	28.1	1.948										
80	11.0	0.488										
100	7.127	0.252										
125	3.19	0.128	8.08	0.325								
150	2.21	0.075	5.6	0.189								
200	0.983	0.031	2.512	0.079								
250					4.05	0.103						
300					2.33	0.059						
350					1.75	0.037						
400							2.684	0.060				
450							2.120	0.042				
500							0.718	0.031				
600							0.927	0.0178				
700							0.682	0.0098				
800									1.14	0.020		
1000									0.619	0.0103		
1200											0.504	0.016
1400											0.371	0.0106
1600											0.251	0.0076
1800											0.177	0.005
1900											0.151	0.0042
2000											0.129	0.0036

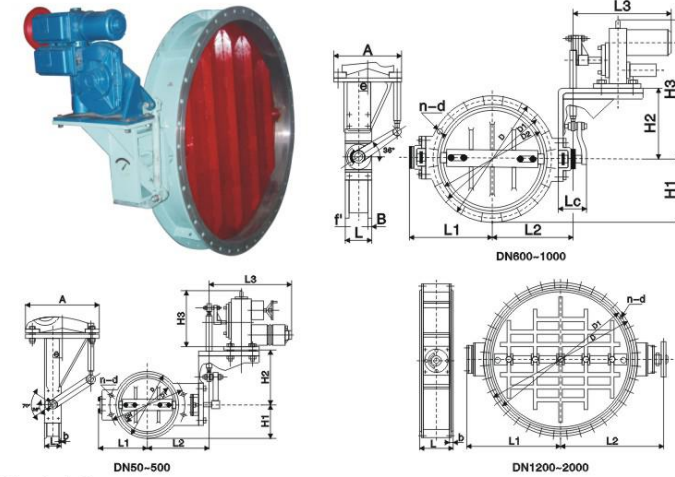

外形尺寸 Physical size

公称口径(mm) Nominal diameter	D	D1	A	e	L	L1	L2	L3	H1	H2	H3	n-d	配执行机构 Match actuator
50	110	245	30	60	92	139	357	55	299	270	4-14	DKJ-210	
80	125	150	245	30	60	92	139	357	62.5	299	270	4-18	DKJ-210
100	145	175	245	30	60	102	149	357	72.5	299	270	4-18	DKJ-210
125	175	200	245	30	60	117	168	357	87.5	299	270	8-18	DKJ-210
150	200	225	245	30	60	130	181	357	100	299	270	8-18	DKJ-210
200	255	280	245	30	70	172	221	357	127.5	299	270	8-18	DKJ-210
250	310	335	300	36	70	197	258	507	155	340	298	12-18	DKJ-310
300	362	395	300	36	80	227	283	507	181	340	298	12-23	DKJ-310
350	412	445	300	36	80	252	290	507	206	340	298	12-23	DKJ-310
400	462	495	365	45	100	296	348	529	231	400	381	16-23	DKJ-410
450	518	550	365	45	100	321	371	529	259	400	381	16-23	DKJ-410
500	558	600	365	45	100	346	396	529	284	400	381	16-23	DKJ-410
600	755	706	365	45	150	480	418	530	377.5	863	482	20-25	DKJ-410
700	860	810	365	45	150	530	531	530	430	863	482	24-25	DKJ-410
800	975	920	420	51	200	595	586	681	487.5	917	480	24-30	DKJ-510
1000	1175	1120	420	51	200	735	721	681	587.5	917	480	28-30	DKJ-510
1200	1400	1340		60	250	906	980					32-34	DKJ-610
1400	1575	1520		60	300	965	1012					36-30	DKJ-610
1600	1785	1730		60	350	1065	1112					40-30	DKJ-610
1800													DKJ-610
1900	2100	2020		60	350	1217	1315					44-30	DKJ-610
20000				60									DKJ-610

订货须知

订货时请填写《规格书》或详细注明以下内容：
1.产品型号 2.公称口径 3.公称压力 4.阀体和阀内件材质 5.转角范围
6.作用方式 7.介质温度 8.输入信号 9.附件

Order instructions

When ordering, please fill in 《specification》 or specify the following contents:
1. The product model 2. Nominal diameter 3. Nominal pressure 4. Body and trims material 5. Angle range
6. Mode of action 7. Medium temperature 8. The input signal 9. Accessories

用途

本蝶阀与电动执行机构配套使用，在冶金、建材、化工、电力等生产过程中，对管道中的高温介质按不同的控制信号改变其流量大小，从而实现工业生产过程的自动控制和远程控制。

USE

This butterfly valve and the electric actuator supporting the use, in metallurgy, building materials, chemical industry, electric power and other production process, the pipe The tao from high temperature medium according to the different control signal to change its flow size, so as to realize industrial production process automatic control And remote control.

主要技术参数 Main technical parameters

表1 Table 1

公称通径(mm) Nominal diameter	150	175	200	250	300	350	400	450	500
额定流量系数 Rated flow coefficient	770	1000	1360	2130	3060	4160	5450	6900	8500
配用电动执行机构 With electric actuator	型号 Model	DKJ-210			DKJ-310			DKJ-410	
	力矩(N.m) Moment	100			250			600	

续 Renewal

600	700	800	900	1000	1200	1400	1600	1800	2000
12200	16600	21700	27100	34000	49600	66600	87000	111000	138000
DKJ-510					DKJ-610				
1600					4000				

表2 Table 2

工作温度 Working temperature	-45~750℃	使用环境温度 Use of the environment temperature	电动执行机构: -10~55℃ Electric actuators: -10 - 55℃
阀板转角 Valve plate Angle	0~70°		伺服放大器: 0~45℃ Servo amplifier: 0 - 45℃
输入信号 Input signal	0~10mA(DC);4~20mA(DC)	环境相对湿度 Environment relative humidity	电动执行机构: ≤95% Electric actuators: ≤95%
公称压力MPa Nominal pressure	0.1~0.6		伺服放大器: ≤85% Servo amplifier: ≤85%
死区 Dead zone	≤0.8%	材料 Wood material	阀体 Valve body Q235-A
回差 Return difference	≤2.5%		阀板 Valve plate 0Cr25Ni20
基本误差 Basic error	±2.5%		轴 Shaft 0Cr25Ni20
泄漏量 leakage	≤1.5%X额定容量 Acuitless 1.5% X rated capacity		填料 Packing 柔性石墨 Flexible graphite
电源电压 Power supply voltage	220V AC 50Hz		内衬 lining 高温混凝土 High temperature concrete

外形及安装尺寸: 外形见图一, 结构见图二, 安装尺寸见表3所示 Appearance and installation dimensions: appearance see chart one, structure see chart 2, installation dimensions, see table 3 shows

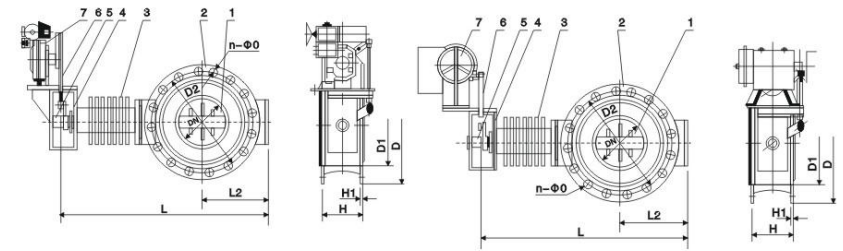
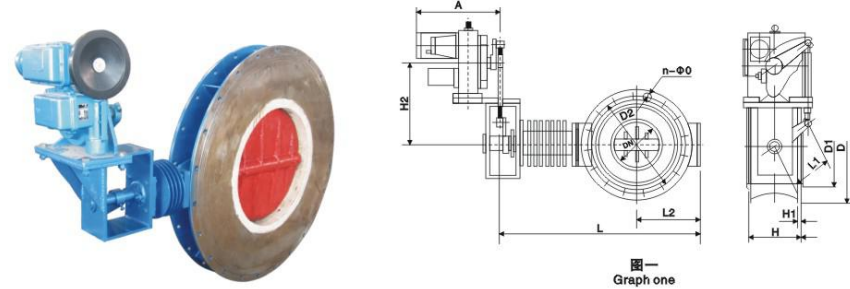

图一 Graph one
图二 Figure 2
1. 阀板 2. 阀体 3. 散热器 4. 支架 5. 阀轴 6. 连杆 7. 伯纳德执行器
1. The valve plate 2. Body 3. Radiator 4. Support 5. Valve shaft 6. Connecting rod 7. Bernard actuator

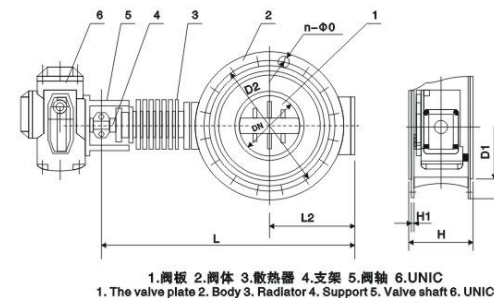

1. 阀板 2. 阀体 3. 散热器 4. 支架 5. 阀轴 6. UNIC
1. The valve plate 2. Body 3. Radiator 4. Support 5. Valve shaft 6. UNIC

图二 Figure 2



ZKJW_B^A-0.1G_B^K型电动高温蝶阀
ZKJW_B^A-0.1G_B^K type electric high temperature butterfly valve

型号编制参照格式一，电气原理详见《DKJ电动执行器使用说明书》Model establishment reference format a, electrical principle see 《DKJ electric actuator specification》

公称通径(mm) Nominal diameter	衬套厚度 δ Liner thickness	D	D1	D2	H	H1	H2	L	L1	L2	A	n-Φ0						
150	100	500	432	455	180	18	271	888	145	290	358	16-Φ20						
175		520	452	475				910		300								
200		550	480	505	190	939		315										
250		605	535	560	993	343												
300	100	650	580	605	200	20	358	1052	160	365	509	18-Φ22						
	150	755	678	705				1152		418								
350	100	705	633	660				25		358			1100	160	393	509	20-Φ24	
	150	805	738	765									1193		468			
400	100	755	678	705	25	358	1152		160		418	509	20-Φ24					
	150	853	777	805			1243				466							
450	100	805	737	765			25	358		1193	160			443	509	20-Φ24		
	150	905	837	765						1294				493				
500	100	853	777	805	210	30			395	1243		182	466	650			22-Φ26	
	150	1005	927	955						1395			543					
600	100	1100	1015	1045			210	30		395	1478		182		590	650		22-Φ26
	150	1100	1015	1045							1478				590			
700	100	1100	1015	1045	210	30			395		1590	182		640	650		22-Φ26	
	150	1200	1115	1145							1590			640				
800	100	1200	1115	1145			210	30		395	1688		182	690		650		22-Φ26
	150	1300	1215	1245							1688			690				
900	100	1405	1320	1350	220	35			500		1796	200		742	666		24-Φ28	
	150	1590	1498	1530							1019			835				
1200	150	1792	1700	1732			240	35		500	2060		235	950		730		28-Φ34
1400	1990	1898	1930	2161							1049							
1600	2195	2090	2130	2450	1150													
1800	2395	2290	2330	2475	1250													
2000	2600	2490	2535	2542	1402													



Z_{SC}^{MA}W-0.1G_B^K型电动高温蝶阀
Z_{SC}^{MA}W-0.1G_B^K type electric high temperature butterfly valve

用途

本蝶阀与气动薄膜式、活塞式执行机构配套使用。在冶金、建材、化工、电力等工业生产过程中，对管道中的高温介质按不同的控制信号改变其流量大小，从而实现工业生产过程的自动控制和远程控制。

Use

This butterfly valve with pneumatic diaphragm, piston type actuator supporting the use. In metallurgy, building materials, chemical industry, electric power and working industry was born production process, the high temperature medium in pipe by the different control signal to change its flow size, so as to realize industrial production process automatic control and remote control.

主要参数 The main parameters

表1Table 1

工作温度 Working temperature	-45~750(°C)	材料 Wood material	阀体 阀板 Body valve plate	0Cr25Ni20
公称压力(MPa) Nominal pressure	0.1(MPa)		轴 Shaft	0Cr25Ni20
阀板转角 Valve plate Angle	0~70°		内衬 lining	高温混凝土 High temperature concrete
信号压力 Signal pressure	0.5(MPa)		填料 Packing	柔性石墨 Flexible graphite
泄漏量 leakage	≤2.5%×额定容量 Rated capacity		流量特性 Flow characteristic	近似等百分比 Approximate equal percentage

ZMAW-0.1G_B^K型主要参数 ZMAW-0.1G_B^K type main parameters

表2Table 2

公称通径(mm) Nominal diameter	150	175	200	250	300	350	400	450	500		
额定流量系数C Rated flow coefficient	770	1000	1360	2130	3060	4160	5450	6900	8500		
执行机构型号 Actuator type	ZMA-3			ZMA-4			ZMA-5				
薄膜有效面积(cm ²) Film effective area	400			630			1000				
最大行程(mm) Maximum stroke	25			40			60				
手轮机构型号 Handwheel mechanism model	ZPS-1				ZPS-2						
最大允许压差 Maximum allowable pressure difference	不带定位器 Don't take locator		15	34	59	81	46	29	48	34	25
	带定位器 With locator		31	30	30	17	98	62	10	71	52

ZSCW-0.1G_B^K型主要参数 ZSCW-0.1G_B^K type main parameters

表3Table 3

公称通径(mm) Nominal diameter	600	700	800	900	1000	1200	1500	1600	1800	2000
额定流量系数C Rated flow coefficient	12200	16600	21700	27100	34000	49600	66600	87000	111000	136000
执行机构型号 Actuator type	ZSC-45					ZSC-56				
活塞有效面积(cm ²) Piston effective area	484					700				
最大行程(mm) Maximum stroke	60					100				
最大允许压差 Maximum allowable pressure difference	0.019	0.012	0.008	0.006	0.004	0.003	0.002	0.002	0.002	0.002
气缸操作压力(MPa) Cylinder operating pressure	0.5									

外形及安装尺寸: Appearance and installation dimensions:
外形见图一、外形安装见表4. Shape see fig.1, appearance installation see table 4.

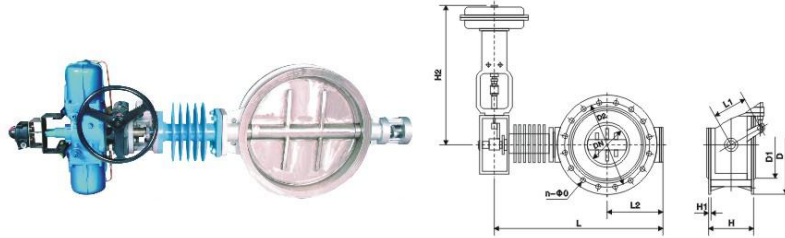

公称通径(mm) Nominal diameter	衬套厚度 δ Liner thickness	D	D1	D2	H	H1	H2	L	L1	L2	n-Φ0				
150	100	500	432	455	180	18	435	888	145	290	16-Φ20				
175		520	452	475				910		300					
200		550	480	505	190	18		939	315						
250		605	535	560				993	343	18-Φ22					
300	100	650	580	605	200	25	720	1052	160	365	20-Φ24				
	150	755	678	705				1152		418					
350	100	705	633	660				20	18	1100		393			
	150	855	738	765						1193		468			
400	100	755	678	705	210	30	1100	1152	182	418	22-Φ26				
	150	853	777	805				1243		466					
450	100	805	737	765				20	18	1193		443			
	150	905	837	865						1294		493			
500	100	853	777	805	210	30	1100	1243	182	466	22-Φ26				
	150	1005	927	955				1395		543					
600	100	1100	1015	1045				210	18	1360		1478	200	590	24-Φ28
	150	1200	1115	1145								1590		640	
700	100	1200	1115	1145	210	30	1410	1590	235		640	28-Φ27			
	150	1300	1215	1245				1688			690				
900	100	1405	1320	1350	240	35		1410	1796	200	742				
	150	1590	1498	1530					1019		835				
1200	150	1792	1700	1732			220		35	1410	2060	235	950	24-Φ28	
1400		1990	1898	1930							2161		1049		
1600		2195	2090	2130	2450	1150									
1800		2395	2290	2330	2475	1250									
2000		2600	2490	2535	2542	1402									

型号编制参照格式一。 Model establishment refer to a format.

外形及安装尺寸 Appearance and installation dimensions
外形见图一、图二，外形安装尺寸见表2、表3。 Shape see fig.1, figure 2, the contour installation dimensions, see table 2 and table 3.

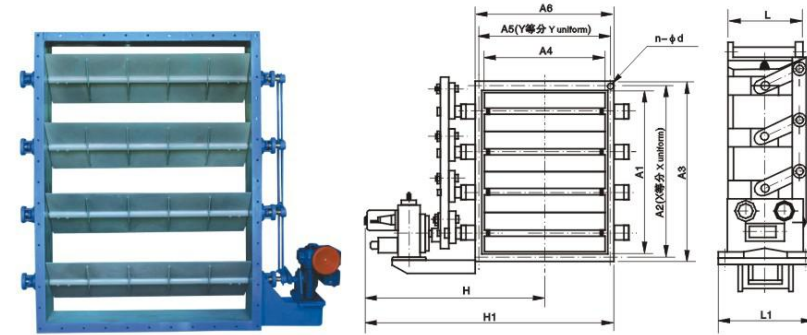

图一 ZSCVb-0.05型手动百叶窗式阀
Graph one ZSCVb-0.05 type manual louver valve

用途

本阀与手轮机构配套使用，具有流量均匀，启闭力矩小、动作灵敏、性能可靠、口径大、重量轻、泄漏量小等优点。广泛应用于冶金、建材、电力、石化、轻工等工业部门的风机、空调器、电收尘中，能对流体介质进行切断和流速控制。

USE

This valve and handwheel mechanism supporting the use, has the flow uniformity, open-close torque is little, action quick, reliable performance, size, weight Light, the advantages of small leakage. Widely used in metallurgy, building materials, electric power, petrochemical industry, light industry and other industrial department's fan, air conditioner, electric charge dust, can the fluid medium for cutting and flow control.

主要技术参数 Main technical parameters

表1 Table 1

工作温度 Working temperature	-30~250℃	材料 Material	阀体 阀板 Body valve plate	Q235-A
公称压力(MPa) Nominal pressure	0.05MPa		轴 Shaft	2Cr13
泄漏率 Leakage rate	≤1.5%		填料 Packing	聚四氟乙烯 Teflon

ZKCVb-0.05型(与风机配套) ZKCVb-0.05 type (and fans supporting)

L	A ₁	A ₂	A ₃	A ₄	A ₅	A ₆	H	H1	L1	x	Y	n-φd	电动执行器 Electric actuators 输入力矩N.m Input torque	配套风 机型号 Supporting fan model			
160	128	160	182	21	126	148	566	462	245	4	3	14-φ7	100	9-19			
	144	176	198	104	135	160	578	468									
	160	192	214	115	150	171	590	476									
	179	212	233	129	162	185	608	480									
160	202	236	256	145	180	204	622	490	245	4	3	14-φ7	100	9-26			
	196	228	250	128	165	184	602	480									
	221	252	275	144	177	200	614	484									
	245	284	299	160	192	216	632	496									
160	274	305	328	179	212	235	732	585	245	5	4	18-φ7	100	9-26			
	309	340	365	202	236	261	648	518									
	227	270	293	163	204	323	620	504									
	256	296	322	184	228	250	670	514									
160	288	330	354	207	252	276	694	526	245	5	4	18-φ10	100	9-19			
	320	360	386	230	275	299	716	537									
	359	415	448	258	316	350	768	563									
	400	458	489	288	314	380	790	570									
160	448	516	557	322	405	488	858	604	245	6	5	22-φ12	100	9-19			
	512	574	621	368	440	484	892	620									
	384	390	414	227	272	196	706	528									
	392	432	458	256	300	323	736	543									
180	441	482	507	288	330	357	758	550	300	6	4	20-φ10	250	9-26			
	490	528	556	320	356	389	799	575									
	504	600	638	358	410	450	860	605									
	613	664	702	400	456	492	902	626									
200	686	747	795	448	516	564	974	682	300	9	6	30-φ12	250	9-26			
	784	840	893	512	588	628	1103	759									
	365	10	7	34-φ12	600	300	6	4							20-φ7	250	Y5-48
	160	256	290	314	199												
324	360	382	252	284	308				718	534							
409	443	465	315	348	371				782	566							
180	520	580	632	400	462	509	919	635	300	5	4	18-φ15	250	Y5-48			
	200	655	728	771	504	570	613	994							687		
	220	815	888	935	627	690	737	1183							814		
	228	256	277	196	228	250	667	511									
160	256	288	300	224	256	278	996	528	245	4	4	16-φ7	100	4-72			
	828	320	341	252	284	306	716	532									
	320	355	374	280	315	336	747	554									
	360	396	414	315	350	371	782	566									
180	400	435	456	350	385	406	816	592	300	7	7	24-φ7	250	4-72			
	180	480	511	536	420	455	476	886							618		
	200	640	700	746	560	625	669	1079							715		
	220	800	860	900	700	765	809	1219							785		
240	960	1008	1066	840	900	949	1434	919	365	6	6	42-φ15	600	4-72			
	260	1280	1340	1380	1120	1188	1232	1702							1056		
	320	1600	1672	1735	1400	1476	1558	2128							1329		
	220	720	777	826	520	580	629	1104							760		
240	810	868	916	586	650	649	1164	810	365	7	5	24-φ15	600	4-72			
	220	900	959	1006	650	710	759	1205							836		
	990	1048	1069	713	780	824	1234	862									
	260	1080	1144	1186	790	846	887	1279							911		
260	1260	1336	1389	910	990	1042	1334	963	424	8	6	28-φ15	1600	Y4-73			
	1540	1312	1569	1010	1120	1172	1642	994									
	1820	1110	1779	1170	1260	1338	1802	1156									
	1800	1890	1959	1300	1386	1462	2052	1253									
420	1980	2070	2139	1430	1560	1596	2186	1385	560	9	7	32-φ15	2500	Y4-73			
	2250	2376	2459	1625	1759	1841	2601	1581									
	450	2520	2660	2732	1805	1905	2036	2736							1718		
	14	10	8	36-φ15	6000	560	10	9							42-φ15	6000	Y4-73
12	9	42-φ15	6000														
14	10	48-φ15	6000														

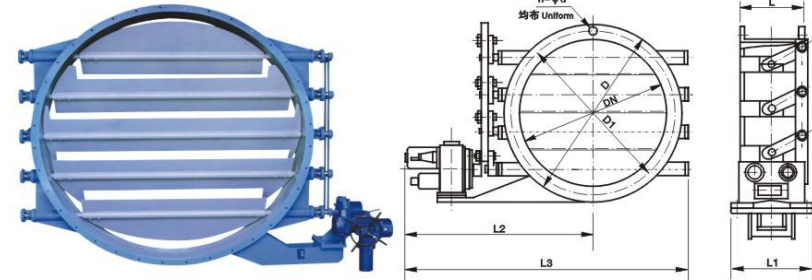

ZKYVb-0.05型外形连接尺寸 ZKYVb-0.05 type appearance connection size

DN	D	D1	L	L1	L2	L3	n-φd	电动执行器 Electric actuators 力矩N.m Moment		
280	306	324	160	300	567	754	8-φ10	250		
320	350	367	180		618	827	16-φ7			
360	394	416			643	876	16-φ7			
450	490	512			801	1082	16-φ10			
500	550	572		200	831	1142	16-φ10	600		
600	650	676	883		1246					
180	205	230	160		520	670			8-φ7	100
200	225	250			535	685				
224	254	284		245	540	702	8-φ10			
250	281	310			558	728				
280	320	360	572		753	8-φ12				
315	355	395	605		830					
355	395	435	180	630	870		12-φ12	250		
400	450	500		715	990					
450	500	550		735	1035					
500	560	620		770	1105					
560	620	680	200	820	1185	16-φ12	600			
630	690	750		835	1235					
710	770	830		875	1315			16-φ12		
800	860	920		930	1415					
900	970	1040	990	1535	16-φ15					
1000	1065	1110	260	1240		1820	24-φ15		1600	
1100	1170	1220		1295		1930		24-φ15		
1120	1190	1250		1310		1960				
1200	1270	1330		1350	2040					
1400	1470	1520	320	1635	2420	28-φ15	2500			
1600	1660	1700		1738	2603					
1800	1860	1900		1825	2800			32-φ15		
2000	2070	2140		1845	2940					
2200	2260	2300	2028	3200	36-φ15	4000				
2500	2560	2620	2175	3500						
2800	2890	2970	2375	3800						
3000	3090	3170	2575	4020			40-φ25	6000		
3500	3610	3680	2870	4620	60-φ25	6000				
4000	4110	4180	3420	5070					68-φ25	8000

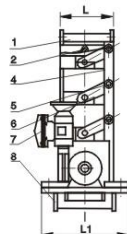
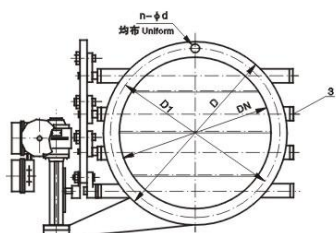

1. 阀体 2. 百叶板 3. 阀轴 4. 连杆 5. 连杆轴 6. 曲柄 7. 伯纳德执行器 8. 支架 (配伯纳德执行机构)
1. The body 2. Blind plate 3. Valve shaft 4. Connecting rod 5. Connecting rod shaft 6. Crank 7. Bernad actuator 8. Support (with Bernad actuator)

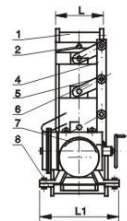
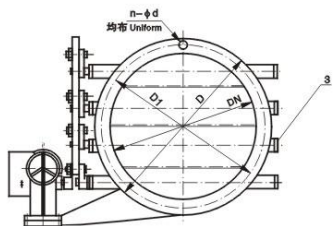

1. 阀体 2. 百叶板 3. 阀轴 4. 连杆 5. 连杆轴 6. 曲柄 7. 松岛执行器 8. 支架 (配日本松岛执行机构)
1. The body 2. Blind plate 3. Valve shaft 4. Connecting rod 5. Connecting rod shaft 6. Crank 7. Pine Island actuator 8. Support (with Japanese pine island actuator)

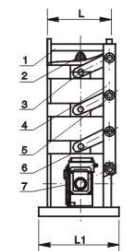
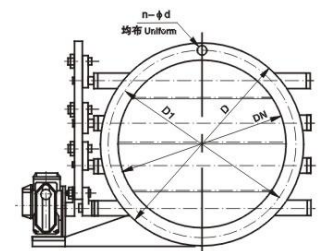

1. 阀体 2. 百叶板 3. 阀轴 4. 连杆 5. 连杆轴 6. 曲柄 7. UNIC执行器 (配日本光荣执行机构)
1. The body 2. Blind plate 3. Valve shaft 4. Connecting rod 5. Connecting rod shaft 6. Crank 7. UNIC actuator (with Japan glorious actuator)

型号编制

ZKCVb-0.05表示电动百叶窗式, 公称压力0.05MPa, C表示窗式, 电气原理详见《DKJ电动执行机构使用说明书》。

Model establishment

ZKCVb-0.05Performance and electric shutter round type, Nominal pressure0.05MPa, C Said window, Electrical principle as shown in the (DKJElectric actuator specification)。

用途

电动圆板阀与电动执行机构配套使用, 广泛应用于冶金、电力、石油、化工、建材等工业部门。实现生产过程的自动控制和远程控制。

USE

Electric circular plate valve and supporting the use of electric actuators, which are widely used in metallurgy, electric power, petroleum, chemical industry, building materials and industry departments. To realize the production process automatic control and remote control.

主要参数 The main parameters

表1 Table 1

公称口径(mm) Nominal diameter	400	450	500	550	600	650	700	900	1000	1060
额定流量系数Kv Rated flow coefficient	5450	6900	8500	10250	12200	14300	16600	27100	34000	38200
配用电动执行机构 With electric actuators	型号 Model	DKJ-310			DKJ-410			DKJ-510		
	力矩(N.m) Moment	250			600			1600		

续Renewal

公称口径(mm) Nominal diameter	1120	1180	1250	1320	1400	1500	1600	1700	1800	1900
额定流量系数Kv Rated flow coefficient	42650	47340	53100	59240	66600	76350	87000	98200	111000	123600
配用电动执行机构 With electric actuators	型号 Model	DKJ-510					DKJ-610			
	力矩(N.m) Moment	1600					4000			

续Renewal

公称口径(mm) Nominal diameter	2000	2120	2240	2240	2500	2650	2800	3000	3150	3350	3550
额定流量系数Kv Rated flow coefficient	136000	152800	170600	189360	212500	239000	366560	306000	338000	382000	428000
配用电动执行机构 With electric actuators	型号 Model	DKJ-610					DKJ-710				
	力矩(N.m) Moment	4000					6000				

表2 Table 2

工作温度 Working temperature	-30~250℃	使用环境温度 Use of the environment temperature	电动执行机构: -10~55℃ Electric actuators: -10~55℃
阀板转角 Valve plate Angle	90°		伺服放大器: 0~45℃ Servo amplifier: 0~45℃
输入、输出信号 Input and output signal	0~10mA 4~20mA	使用环境相对湿度 Use environment relative humidity	电动执行机构: ≤55% Electric actuators: 55% or less
公称压力(MPa) Nominal pressure	0.1MPa		伺服放大器: ≤85% Servo amplifier: 85% or less
死区 Dead zone	≤0.8%	材料 Wood material	电源、电压 Power, voltage 220V AC 50Hz
回差 Return difference	≤2.5%		阀体、阀板 Power, voltage Q235-A
基本误差 Basic error	≤2.5%		轴Shaft 2Cr13
泄漏量 leakage	≤1.5%		填料Packing 聚四氟乙烯 Teflon



DYF系列电动圆板阀 DYF series of electric circular plate valve

外形及安装尺寸 Appearance and installation dimensions

外表见图一，外形及安装尺寸见表三 Appearance see fig.1, appearance and installation dimensions are shown in table 3

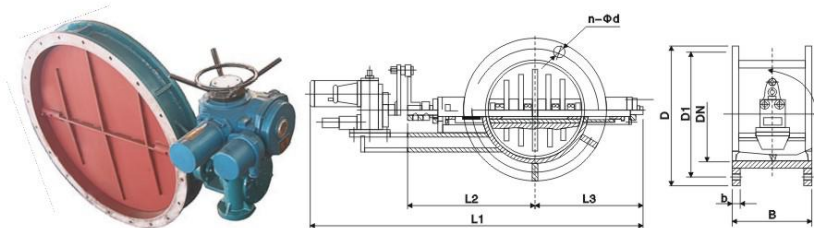

图一 Graph one

6000J型电动高温蝶阀 6000J type electric high temperature butterfly valve

表3 Table 3

DN	D	D1	L1	L2	L3	B	b	n-Φd
400	500	455	1410	450	300	350	8	12-Φ18
450	550	505	1530	490	340	350	8	16-Φ18
500	600	555	1620	520	380	350	8	16-Φ18
550	650	605	1700	530	420	350	8	16-Φ18
600	700	655	1760	610	460	400	8	16-Φ18
650	750	705	1830	650	500	400	8	16-Φ18
700	800	755	1900	680	540	400	8	16-Φ18
800	926	870	2020	730	600	450	10	20-Φ22
900	1026	970	2165	780	670	450	10	20-Φ22
1000	1133	1070	2270	850	720	450	12	28-Φ24
1060	1193	1130	2330	880	750	500	12	28-Φ24
1120	1253	1190	2390	910	780	500	12	28-Φ24
1180	1313	1250	2655	1010	850	500	12	32-Φ24
1250	1383	1320	2725	1045	880	600	12	32-Φ24
1320	1453	1390	2795	1060	920	600	12	32-Φ24
1400	1533	1470	2875	1120	960	600	12	36-Φ24
1500	1633	1570	2975	1170	1010	600	12	36-Φ24
1600	1733	1670	3336	1340	1140	700	18	40-Φ24
1700	1833	1770	3426	1390	1190	700	18	40-Φ24
1800	1933	1870	3526	1440	1240	700	18	44-Φ24
1900	2033	1970	3626	1490	1290	700	18	44-Φ24
2000	2133	2070	3825	1575	1350	800	18	48-Φ24
2120	2253	2190	3945	1635	1410	800	18	48-Φ24
2240	2375	2310	4065	1695	1470	800	18	48-Φ24
2360	2493	2430	4185	1755	1530	800	18	48-Φ24
2500	2633	2570	4325	1825	1600	800	18	52-Φ24
2650	2783	2720	4475	1900	1675	800	18	56-Φ24
2800	2933	2870	4625	1975	1750	800	18	60-Φ24
3000	3133	3070	4825	2075	1850	800	18	60-Φ24
3150	3283	3220	4975	2150	1925	800	18	64-Φ24
3350	3483	3420	5175	2250	2025	800	18	68-Φ24
3550	3683	3620	5375	2350	2125	800	18	72-Φ24

型号编制说明：如DYF-160表示电动圆板阀通径为DN1600mm
Model establishment description: such as DYF-160 indicates electric circular plate valve size for DN1600mm



手动调节阀系列 Manual control valve series



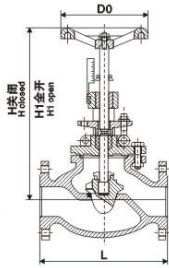

法兰连接手动调节阀(TJ40H型)
Flange connection manual control valve (TJ40H type)

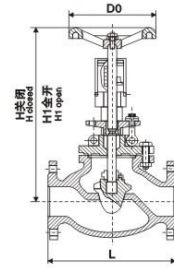

法兰连接自锁手动调节阀(TS40H型)
Flange connection self-locking manual control valve (TS40H type)

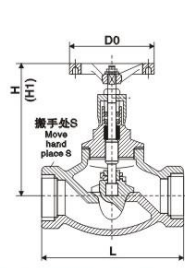

内螺纹连接自锁手动调节阀(TJ10H型)
Female thread connection self-locking manual control valve (TJ10H type)

概述

本公司生产的手动调节阀及自锁手动调节阀主要用于城市集中供热，循环水工程热电厂管网和制冷空调等工程中，具有截止、节流和调节流量的作用，可取代节流孔板，是一种可变孔径的节流装置，介质温度： $\leq 425^{\circ}\text{C}$ 。

Overview

The company produces the manual control valve and self-locking manual control valve is mainly used for urban centralized heat supply, thermal power plant circulating water engineering network and refrigeration and air conditioning projects, has the cut-off, throttle and Flow adjustment role, can be replaced the throttling orifice plate, is a kind of variable diameter of the throttle device, medium temperature: $\leq 425^{\circ}\text{C}$.

主要零件材料 The major parts material

零件材料 Parts material	阀体、阀盖、填料压盖 Valve body, valve cover, gland	阀杆、阀瓣、密封圈 Stem and disc, sealing ring	指示盘、阀杆螺母、螺帽套 Indicator panel, stem nut, nut set
材料 Wood material	灰铸铁、铸钢、不锈钢 Gray cast iron, cast steel, stainless steel	不锈钢 Stainless steel	黄铜 Brass

主要外型尺寸（法兰连接尺寸：PN10按GB4216标准，PN16、PN25按JB/T97-94标准）The main appearance size (flange connection dimension: PN10 according to GB4216 standard, PN16, PN25 according to JB/T97-94 standard)

型号 Type number	尺寸(mm) size																				
	DN	15	20	25	32	40	50	65	80	100	125	150	200	250	300	350	400	450	500	600	
TJ40H-10 TS40H-10	L														622	698	787	914	978	978	1295
	H														914	914	968	968	1100	1440	1790
	H1														1074	1074	1168	1168	1350	1440	1790
D0																					
TJ40H-16 TJ40H-16C TS40H-16	L	130	150	160	180	200	230	290	310	350	400	480	495								
	H	160	160	182	192	250	264	380	413	468	540	623	687								
	H1	172	172	195	210	273	290	426	468	530	613	698	777								
TJ40H-25 TS40H-25	D0	65	65	80	80	120	120	200	200	240	280	360	400								
	L	90	100	120	140	170	200														
	H	150	160	182	192	250	264														
TJ10H-10 TJ10H-16C TJ10H-25	H1	160	170	197	207	270	284														
	D0	80	80	80	90	100	120														

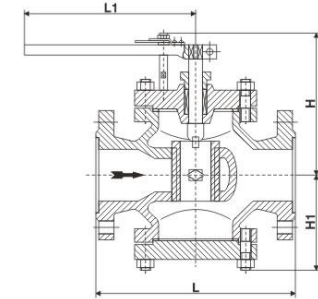

概述

给水回转式调节阀由阀体、阀座、阀瓣、阀杆、阀盖等零件组成。它安装在油、水等管路上，通过转动圆筒形阀瓣来改变阀瓣与阀座所形成的窗口面积的大小，从而实现调节流量的目的。调节阀的启闭角度为 60° ，由安装在调节阀上方的开度指示板来指示。介质温度： $0-170^{\circ}\text{C}$ 。

Overview

Feed rotary valve by valve body, valve seat and valve disc and stem, valve cover, and other integral parts. It installed in oil and water piping, through the rotating cylindrical valve disc to change valve disc and seat the form into the window of the size of the area, so as to realize the purpose of flow adjustment. The valve opening and closing Angle for 60° , the installed on top of the regulating valve opening indicator board to instructions. Medium temperature: $0-170^{\circ}\text{C}$.

主要零件材料 The major parts material

零件材料 Parts material	阀体 Valve body	阀盖 Valve cover	阀座、阀瓣、阀杆 Seat, disc, stem
主要材料 Main material	灰铸铁、铸钢 Gray cast iron, cast steel	灰铸铁、铸钢 Gray cast iron, cast steel	不锈钢 Stainless steel

主要外型尺寸（法兰尺寸按JB/T97-94标准）The main appearance size (flange size according to JB/T97-94 standard)

公称压力(MPa) Nominal pressure	尺寸Size (mm)													
	DN	20	25	32	40	50	65	80	100	125	150	200	250	300
1.6	L	160	180	200	220	250	280	310	350	400	450	500	650	800
	L1	140	150	180	200	230	240	270	300	350	380	440	500	650
	H	180	200	205	210	230	230	250	250	290	300	325	330	450
2.5	L	90	100	107	113	120	125	140	150	190	205	270	270	330
	H	160	180	200	220	250	280	310	350	400	450	500	650	800
	H1	150	160	180	210	245	260	290	320	370	410	480	540	700
4.0	L	180	200	205	210	230	230	250	290	300	310	335	350	470
	H	180	200	205	210	230	240	250	290	300	310	335	350	470
	H1	90	100	110	113	120	130	150	170	190	210	220	290	360
6.4	L	180	200	220	240	270	300	330	380	450	500	550	650	800
	L1	160	170	200	230	260	290	320	350	400	440	530	600	760
	H	185	210	220	225	250	250	260	300	310	320	340	360	480
10.0	H1	100	110	110	135	135	140	160	180	200	220	230	300	370
	L	180	200			300	315	380	400			450		
	Li	180	200			280		380	470			414		
H	150	165			240		270	280			360			
	H1	105	115			130		190	190		250			

概述

自力式调节阀是一种无需外来能源,依靠被调介质自身的压力、温度、流量变化进行自动调节的节能仪表。具有测量、执行、控制的综合功能,广泛用于城市供热、供暖系统及石油、化工、冶金、电站、轻工等工业部门的自控系统中。城市供热、供暖系统采用该产品,热效率可提高30%~40%,既经济又不污染环境,节能效果十分明显。

目前,由于各种因素的影响(包括工艺参数不准确,计算公式及计算方法上的差异及实际工艺条件与计算时所考虑的工艺条件不一致,加上不可见的因素),根据理论上计算出的数据,往往选择出的调节阀口径过大或过小。过大使阀门经常在小开度下工作,阀门磨损严重,引起振荡或噪音,甚至自动调节失灵;阀选择过小时,阀门工作时开度过大,超负荷运行,不能满足流量要求,容易出现事故,造成不必要的浪费和损失。另外选择时,采用的工业不合理,选择的材料、公称压力不合适及使用不当等同样会造成阀工作中出现问题,也会造成不必要的浪费和损失。

Overview

Self type valve is a kind of without external energy, rely on the modulated medium own pressure, temperature, flow changes in automatic adjustment of the energy saving instrument. In measurement, implementation, control of the ensemble Close function, widely used in urban heating, heating system and petroleum, chemical industry, metallurgy, power generation, light industry and other industrial departments in the automatic control system. City heating, heating system using this product, heat Efficiency can be increased by 30%~40%, namely the economy and polluting the environment, energy conservation effect obviously.

At present, due to the influence of various reasons (including process parameters not accurate, calculation formula and calculation methods of the differences and the actual process conditions and calculation consider process conditions are not consistent, Add unforeseeable factors), according to the theoretically calculated data, often choose out of the regulating valve size too big or too small. After the ambassador valve often work under small open degree, the valve wear serious, Cause oscillation or noise, and even automatic regulation failure; Valve selection after hours, when valve work through open, overload operation, can't meet the flow requirements, is easy to appear the accident, cause unnecessary waste and loss. In addition when the choice, the industry is unreasonable, choice of materials, nominal pressure don't fit and use undeserved, etc. Also can cause valve work appear problem, also can cause don't have to To waste and loss.

那么, 如何选择合适的自力式调节阀就显得极为重要, 在选择前, 请先了解一下本公司所生产的自力式调节阀的情况:

So, how to choose appropriate self type valve is very important, in the choice before, please first understand a this company produces the self type valve:

自力式调节阀的技术参数、特点、选型及应用举例

我公司生产的自力式调节阀主要分为自力式压力调节阀、自力式温度调节阀、自力式差压调节阀及自力式流量调节阀等。由于其用途不同, 选择的方法不尽一致, 除了计算口径以外, 还应根据各种阀的用途和特点, 根据实际工况进行选择。例如压力阀调压范围的选择, 温度阀调温范围的选择及流量阀有效压力的选择等。

本公司的产品具有以下特点:

- a. 具有压力平衡功能, 灵敏度高; b. 免于维护, 性能可靠; c. 低噪音; d. 通过组合件, 可以进行多项组合控制; e. 采用标准模块化设计。

另外, 自力式调节阀在阀芯与阀座的密封形式上分为硬密封和软密封。

两者之间的区别为: 硬密封指阀芯与阀座互相密封的部位均是硬接触, 即不锈钢与不锈钢接触, 泄漏量相对偏大, 适用液体介质及温度较高或对泄漏要求不是很严格的工况; 软密封指阀座为不锈钢, 阀芯密封部位为橡胶, 阀芯与阀座接触为软与硬接触, 泄漏量相对较小, 适用于一般气体及要求泄漏相对严格的工况, 但不适于温度大于140℃的介质。控制阀型号中“0”代表硬密封, “1”代表软密封。例V230为硬密封, V231为软密封。

自力式调节阀的整机由控制阀和执行器两部分组成。例如产品型号V230DOI, V230T06, V230D05, 其中V230为控制阀型号, D01, T06, D05为执行器型号。

Self type valve technical parameters, characteristics, selection and applied examples

Our company produces the self type valve is mainly divided into self type pressure regulator, self type temperature control valve, self type differential pressure control valve and self type flow control valve, etc. Because of its use don't With the, choice of methods are consistent, in addition to outside diameter calculation, but also should be based on all kinds of valve USES and features, according to the actual working condition selection. Such as pressure valve regulating range of choice, temperature Valve temperature range of selection and flow valve effective pressure selection, etc.

The products of this company has the following features:

- a, has the pressure balance function, high sensitivity; b, free from maintenance, reliable performance; c, low noise; d, through the assembly, can undertake a number of combination contro; e, adopt standard modular design

In addition, self type valve in the valve core and valve seat sealing form is divided into hard seal and soft seal.

The difference between the two is: hard seal refers to the valve core and valve seat sealing parts of each other are hard contact, i.e., stainless steel and stainless steel contact, leakage comparatively big, it is suitable for liquid medium and temperature Higher or to leak the demand is not very strict condition; Soft seal refers to seat for stainless steel, valve core for rubber sealing parts, valve core and valve seat contact for soft and hard contact leakage, relatively small, comfortable Used for general gas leakage and requirements relative strict conditions, but is not suitable for temperature greater than 140℃ medium. Control valve type "0" for hard seal, "1" on behalf of the soft seal. V230 cases for hard Seal, V231 for soft seal.

Self type valve of the whole machine consists of control valve and actuator of two parts. Such as product model V230DOI, V230T06, V230D05, which V230 for control valve type, D01, T06, D05 shape for the implementation of the number.

自力式压力调节阀系列
Self type pressure regulating valve series

型号 Model

类别 Class don't	压力控制调节阀 Pressure control valve				差压控制调节阀 Differential pressure control valve			
	阀后压力调节阀 After the valve pressure regulator	阀前压力调节阀 Valve former pressure regulator	差压上升阀关闭 Differential pressure rise valve closed	差压上升阀开启 Differential pressure rise valve open	硬密封 Hard seal	软密封 Soft seal	硬密封 Hard seal	软密封 Soft seal
型号 Type number	V230D01	V231D01	V230D02	V231D02	V230D03	V231D03	V230D04	V231D04

控制阀主要技术参数 Control valve main technical parameters

公称直径(mm) Nominal diameter	15	20	25	32	40	50	65	80	100	125	150	200	250
额定流量系数 Kvs The rated flow coefficient	4	6.3	8	16	20	32	50	80	125	160	280	320	400
噪声测量系数 Z 值 Noise measure coefficient Z value	0.6	0.6	0.6	0.55	0.55	0.5	0.5	0.45	0.4	0.35	0.3	0.2	0.2
公称压力(MPa) Nominal pressure	1.6; 4.0												
最高工作温度(°C) Maximum operating temperature	液体 ≤140; 气体 ≤80 Liquid ≤140; Gas ≤80												
	硬密封 Hard seal	配隔离罐 ≤200 With isolation tank ≤200										配隔离罐和加长件 ≤300 With isolation tank and extensions ≤300	
法兰标准 Method or standard	ANSI, JIS, DIN, GB, JB(特殊可按用户提供 Special according to users)												
阀体材质 Valve body material quality	铸铁: 铸钢; 铸不锈钢 Cast iron, cast steel, Cast stainless steel												
阀芯材质 Valve core material quality	不锈钢, 软密封为不锈钢镶嵌橡胶圈 Stainless steel, soft seal for stainless steel Moselco rubber ring												
最高工作压力 Maximum working pressure	公称压力(注意 ΔPmax 及工作压力与工作温度的关系) Nominal pressure (Pay attention to ΔPmax And the pressure of work and working temperature relationship)												

执行器主要技术参数 Actuator main technical parameters

产品型号 Product model	V230D01(D03); V231D01(D03)				V230D02(D04); V231D02(D04)			
有效面积(cm²) Effective area	32*	80*	250	630	32*	80*	250	630
压力设定范围(Mpa) Pressure setting range	0.8~1.6	0.1~0.6	0.015~0.15	0.005~0.035	1.0~1.6	0.1~0.5	0.015~0.12	0.005~0.035
	0.3~1.2	0.05~0.3	0.01~0.07		0.3~1.1	0.05~0.25	0.01~0.06	
保证压力阀正常工作最小压差 ΔPmin(MPa) Ensure that pressure valve normal work minimum differential pressure trsin Pmin	≥0.05	≥0.04	≥0.01	≥0.005	≥0.05	≥0.04	≥0.01	≥0.005
允许上下膜室之间最大压差(Mpa) Allow fluctuation members room between maximum differential pressure	2.0	1.25	0.4	0.15	2.0	1.25	0.4	0.15
材质 Material quality	膜盖: 钢板镀锌; 膜片: EPDM或FKM夹纤维 Membrane cover: steel galvanized; diaphragm: EPDM or FKM clamp fiber							
控制管线、接头 The control line, joint	铜管或钢管 10×1; 卡套式接头 R1/4" Copper tube or pipe 10×1; Cutting sleeve type joint R1/4"							

注: *该有效面积所对应的压力设定范围不适用于 DN150~250。
Note: *The effective area of the corresponding pressure setting range does not apply DN150~250.

性能指标 Performance index

控制精度 Control accuracy	± 8%			
允许泄漏量 (在规定试验条件下) Allow leakage (in the regulation test conditions)	硬密封 Hard seal	4 × 10 ⁻⁴ 阀额定容量 4 × 10 ⁻⁴ valve rated capacity		
	软密封 Soft seal	DN15~50	DN65~125	DN150~250
		10气泡/min 10 bubble/min	20气泡/min 20 bubble/min	40气泡/min 40 bubble/min

允许压差 Allow differential pressure

公称直径(mm) Nominal diameter	15	20	25	32	40	50	65	80	100	125	150	200	250
最大允许压差 ΔP(MPa) Maximum allowable pressure difference	PN16	1.6							1.5	1.2	1.0		
	PN40	2.0											

结构简图如下 Structure diagram below



图1a Figure 1a
V230D01
V231D01 DN15-125



图1b Figure 1b
V230D02
V231D02 DN15-125

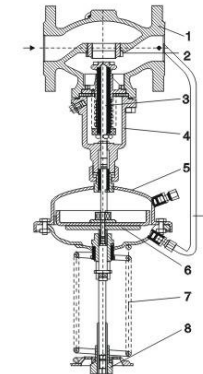

图1c Diagram 1c
V230D03
V231D03 DN15-125

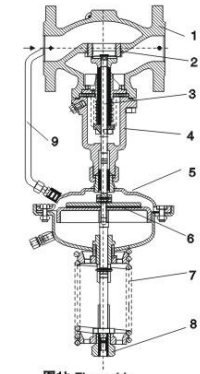

图1d Figure 1d
V230D04
V231D04 DN15-125

1	阀体 Body	2	阀座 Seat	3	阀芯 Valve core	4	阀盖 Valve cover	5	膜盖 Membrane cover
6	膜片 Diaphragm	7	弹簧 Spring	8	调节螺母 Adjusting nut	9	导压管 Connecting pipe		

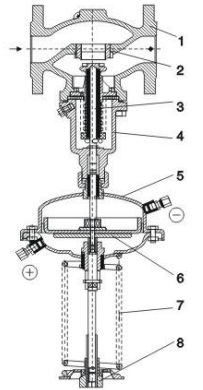

DN150-250

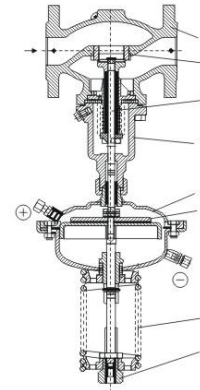
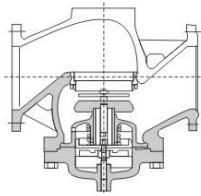
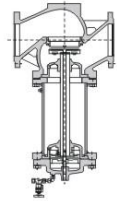

DN150-250带有筒体加长件,耐温至200℃
DN150-250 with body extensions, heat resistance to 200 °C

工作原理

(1) 作阀后压力调节时的工作原理: (见图1a)

工艺介质的阀前压力P1经过阀芯、阀座的节流后,变为阀后压力P2。P2经过控制管输入到执行器的下膜室内作用在顶盖上,产生的作用力与弹簧的反作用力相平衡,决定了阀芯、阀座的相对位置,控制阀后压力。当阀后压力P2增加时,P2作用在顶盖上的作用力也随之增加。此时,顶盖的作用力大于弹簧的反作用力,使阀芯向阀座的位置,直到顶盖的作用力与弹簧反作用力相平衡为止。这时,阀芯与阀座之间的流通面积减少,流阻变大,从而使P2降为设定值。同理,当阀后压力P2降低时,作用方向与上述相反,这就是阀后压力调节时的工作原理。

当需要改变阀后压力P2的设定值时,可调整调节螺母。

(2) 作阀前压力调节时的工作原理: (见图1b)

工艺介质的阀前压力P1通过阀芯、阀座节流后变为阀后压力P2,同时P1通过控制管输入到执行器的上膜室内作用在顶盖上,产生的作用力与弹簧的反作用力相平衡,决定了阀芯、阀座的相对位置,控制阀前压力。当阀前压力P1增加时,P1作用在顶盖上的作用力也随之增加。此时,顶盖上的作用力大于弹簧的反作用力,使阀芯向离开阀座方向移动,直到顶盖的作用力与弹簧反作用力相平衡为止。这时,阀芯与阀座之间的流通面积变大,流阻变小,从而使P1降为设定值。同理,当阀前压力P1降低时,作用方向与上述相反,这就是阀前压力调节时的工作原理。

当需要改变阀前压力P1的设定值时,可调整调节螺母。

(3) 作差压控制时的工作原理: (图1c、图1d及安装示例)

工艺介质通过调节阀后,进入被控设备,而被控设备的差压,分别引入阀的上、下膜室,在上、下膜室内产生推力,并与弹簧反力相平衡,从而确定了阀芯与阀座的相对位置,而阀芯与阀座的相对位置确定了差压值 ΔP 的大小。当被控差压变化时,力的平衡被破坏,从而带动阀芯运动,而阀芯的运动改变了阀的阻力系数,即控制了被控差压值为设定值。这就是差压控制的工作原理。

当需要改变差压设定值时,可调整调节螺母。

Working principle

(1) after valve pressure regulation of working principle: (see chart 1 a)

Process medium valve front pressure P1 after valve core and valve seat of the throttle, after a valve pressure P2. P2 after control line input to the implementation of the next film indoor role in terminal disc, creating of Force and spring reaction of phase equilibrium, determines the valve core and valve seat of relative positions, control valve after pressure. When the valve after pressure P2 increases, the P2 role in terminal disc on the force will be increased Add. At this time, the particular force greater than spring reaction force, make the valve core valve close to the seat position, in particular until the force and spring reaction phase equilibrium so far. At this time, the valve core and valve Seat between the circulation area reducing, flow resistance change, so that the P2 reduced to set value. Similarly, when the valve after pressure P2 reduce, the function direction and the contrary, this is the valve after the pressure regulation Working principle.

When the need to change the valve pressure P2 after the set value, can adjust adjusting nut.

(2) before valve pressure regulation of working principle: (see chart 1 b)

Process medium valve front pressure P1 through the valve core and valve seat throttle to valve after pressure P2, and at the same time, P1 through the control line input to the implementation of the film on indoor role in terminal disc, creating of Force and spring reaction of phase equilibrium, determines the valve core and valve seat of relative positions, control valve front pressure. When the front pressure P1 increases, the role of the terminal disc P1 of force also will increase. At this time, the particular force greater than spring reaction force, make the valve core to leave the seat direction until terminal disc of force and spring reaction phase equilibrium so far. At this time, the valve core and valve Seat between circulation area bigger, small flow resistance, thus make P1 reduced to set value. Similarly, when the front pressure P1 reduce, the function direction and the contrary, this is the valve before pressure regulation of work Principle.

When the need to change the valve before pressure P1 value, can adjust adjusting nut.

(3) for differential pressure control work principle: (figure 1 c, figure 1 d and installation example)

Process medium through the valve throttle, into the accused of equipment, and the control equipment of the differential pressure, respectively introduce valve of upper and lower membrane room, in the upper and lower membrane indoor produce thrust, and with spring reaction phase flat Scale, so as to determine the valve core and valve seat of relative positions, and the valve core and valve seat to determine the relative position of the differential pressure value train P size. When he was accused of differential pressure change, force balance is destroyed, thus belt

Moving valve core movement, and valve core movement changed valve resistance coefficient, i.e., the controlling the accused of differential pressure value is set point. This is the working principle of differential pressure control.

When the need to change the differential pressure setting value, can adjust adjusting nut.

选择时注意事项

- ① 压力阀主要应用在被控参数一旦调定后,不经常改变(调整)的场合。
- ② 被控压力参数不应接近或超过选择的压力调整范围的极限值,应根据工艺情况留有一定余量。
- ③ 介质应按阀所示箭头的方向流动,工业流程中,不允许出现介质反方向流动的情况。
- ④ 阀前应安装过滤器(如无安装条件,应将管道内吹扫干净,避免焊渣或其它管内残留物将阀堵塞,造成损失)。
- ⑤ 当介质温度低于80℃时,阀门可正立或倒立安装,当介质温度高于80℃时,阀门必须倒立安装,即阀体在上,执行器在下。
- ⑥ 阀门进出口应保留有一定的直管段(一般进口为10倍阀门通径,出口为5倍阀门通径),并安装压力表、截止阀和旁路,以备调整和检修。
- ⑦ 阀门如缩径,幅度不应太大,一般不超过2-3档,如工艺要求缩径较大,直管段应尽量加长。
- ⑧ 室内安装用于煤气、天然气等易燃易爆气体时,现场通风不好或无漏气报警装置,应在执行器上加接引流通管到室外,保证安全。(阀后压力调节,接在上膜盖接头上,阀前压力调节,接在下膜盖接头上)。
- ⑨ 调节时,参照压力表旋转调节螺母至所需控制的压力值。
- ⑩ 安装示意图

When the choice the matters needing attention

- ① the pressure valve is mainly applied in controlled parameter once set-up, often do not change (adjust) place together.
- ② was accused of pressure parameters should not be close to or more than choice of pressure adjustment range of limit value, should be based on process with a certain margin.
- ③ medium should press valve shows the direction of the arrow flow, industrial process, are not allowed to appear medium reverse direction of flow of situation.
- ④ before the valve should be installed filter (if no installation conditions, should be within the pipeline purging clean, avoid welding slag or other things will remain inside the valve jam, loss).
- ⑤ when the medium temperature below 80 °C, the valve can be made or inverted installation, when the medium temperature higher than 80 °C, the valve must be inverted installation, namely in the body, the actuator next.
- ⑥ valve import and export shall ensure that leave certain straight section (general import to 10 times the valve size, export as 5 times valve size), and install pressure gauge, out-off valve and bypass for adjustment and maintenance.
- ⑦ valves such as reducing the amplitude should not be too big, generally not more than 2-3 files, such as technological requirements reducing is bigger, straight pipe section should as far as possible lengthen.
- ⑧ indoor installations used for gas, natural gas, etc of inflammable and explosive gas, field and ventilated bad or no gas leakage alarm device, should be in actuators and joint drainage tube pass outside, ensure safety. (valve pressure after Force control, and then in the membrane cover joint, valve former pressure regulation, and then in the next film cover joint).
- ⑨ regulation, reference gauge rotating adjusting nut to the necessary control pressure value.
- ⑩ Installation plan

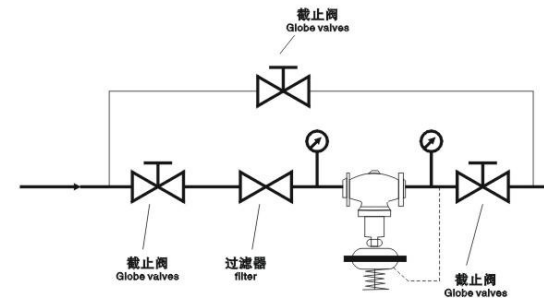

外形尺寸及重量 Physical size and weight

控制阀尺寸及重量 Control valve size and weight

公称通径(mm) Nominal diameter	15	20	25	32	40	50	65	80	100	125	150	200	250
L(mm)	130	150	160	180	200	230	290	310	350	400	480	600	730
B(mm)	212	212	238	238	240	240	275	275	380	380	295	325	372
大约重量(kg) About weight	6.2	6.7	9.7	13	14	17	29	33	60	70	80	140	220

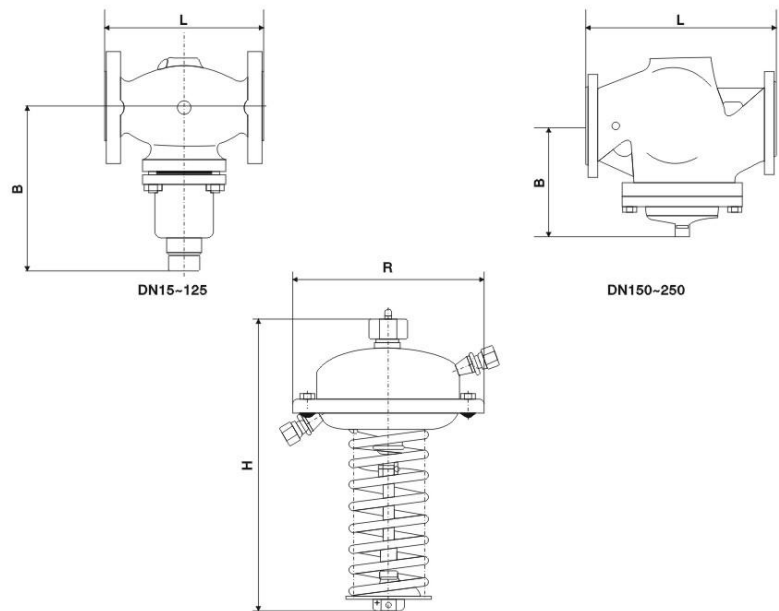

订货时须提出下列条件

- | | |
|--------|---------------|
| ① 产品型号 | ⑤ 压力设定范围和有效面积 |
| ② 公称口径 | ⑥ 阀体材料 |
| ③ 公称压力 | ⑦ 介质种类及工作温度 |
| ④ 法兰标准 | ⑧ 有无特殊要求 |

When placing order, please put forward the following conditions

- | | |
|------------------------|---|
| ① the product model | ⑤ pressure setting range and effective area |
| ② the nominal diameter | ⑥ body material |
| ③ nominal pressure | ⑦ medium type and working temperature |
| ④ the flange standards | ⑧ have special requirements |

执行器尺寸及重量 Actuator size and weight

有效面积cm ² Effective area	32	80	250	630
ΦR mm	172	172	263	380
H	D01(D03)	435	430	470
	D02(D04)	440	435	440
大约重量kg About weight	7.5	7.5	13	28

应用简例 Application Jane cases

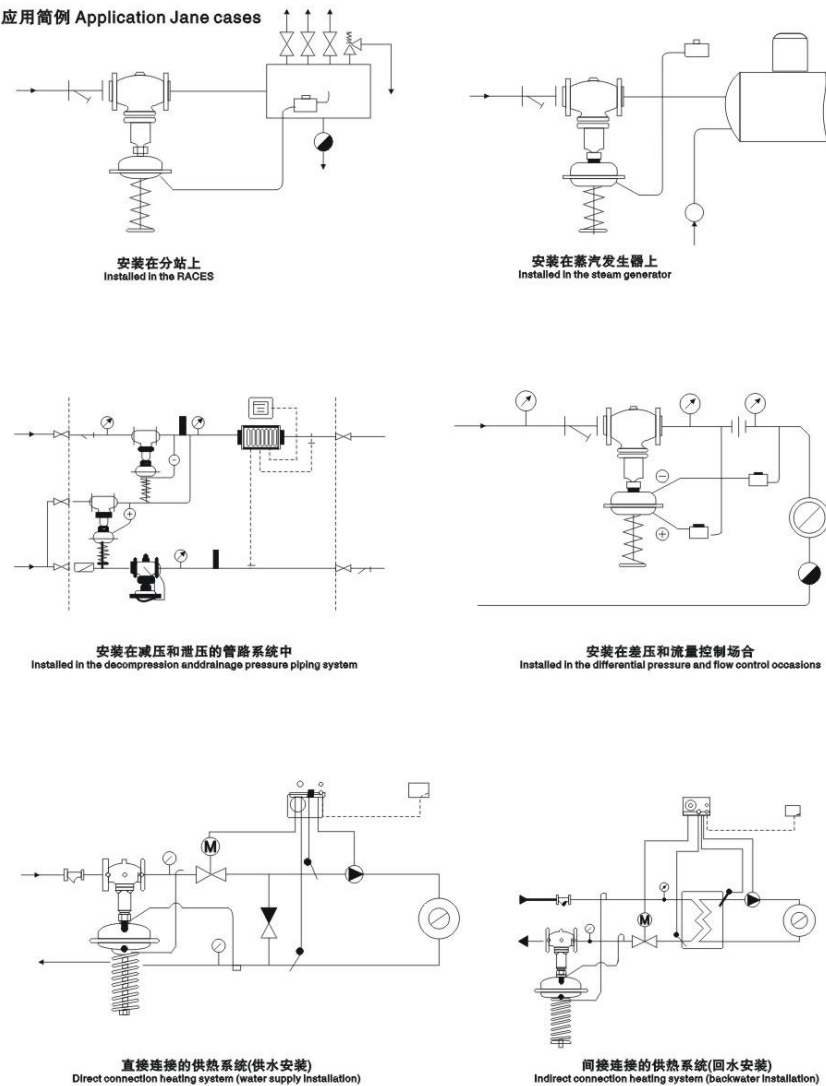

安装在分站上
Installed in the RACES

安装在蒸汽发生器上
Installed in the steam generator

安装在减压和泄压的管路系统中
Installed in the decompression and drainage pressure piping system

安装在差压和流量控制场合
Installed in the differential pressure and flow control occasions

直接连接的供热系统(供水安装)
Direct connection heating system (water supply installation)

间接连接的供热系统(回水安装)
Indirect connection heating system (backwater installation)

指挥器操作型自力式压力调节阀主要用于各种过程控制中的阀前及阀后压力调节，可用于最高温度300℃的非腐蚀性的液体、气体和蒸汽等介质。
Command device operational pressure regulating valve is mainly used for all kinds of process control of the valve before and after valve pressure adjustment, can be used for the highest temperature 300 °C noncorrosive liquids, gases and steam, and other media.

型号 Model

类别 Class don't	阀后压力调节阀 After the valve pressure regulator		阀前压力调节阀 Valve former pressure regulator	
	硬密封 Hard seal	软密封 Soft seal	硬密封 Hard seal	软密封 Soft seal
型号 Type number	V230D12	V231D12	V230D13	V231D13

控制阀主要技术参数 Control valve main technical parameters

公称通径(mm) Nominal diameter	15	20	25	32	40	50	65	80	100	125	150	200	250
额定流量系数Kvs The rated flow coefficient	4	6.3	8	16	20	32	50	80	125	160	280	320	400
噪音衡量系数Z值 Noise measure coefficient Z value	0.6	0.6	0.6	0.55	0.55	0.5	0.5	0.45	0.4	0.35	0.3	0.2	0.2
公称压力(MPa) Nominal pressure	1.6; 4.0												
最高工作温度(°C) Maximum operating temperature	液体 ≤140; 气体 ≤80 Liquid ≤140; Gas ≤80												
	硬密封 Hard seal	配隔离罐 ≤200 With isolation tank ≤200					配隔离罐和加长件 ≤300 With isolation tank and extension ≤300			配隔离罐和散热片 ≤300 With isolation tank and fin ≤300			
压力平衡元件 Pressure balance element	波纹管 Bellows											滚动膜片 Rolling diaphragm	
法兰标准 Method orichid scale must	ANSI、JIS、DIN、GB、JB(特殊可用用户提供 Special according to users)												
阀体材质 Valve body material quality	铸铁; 铸钢; 铸不锈钢 Cast iron; Cast steel; Cast stainless steel												
阀芯材质 Valve core material quality	不锈钢, 软密封为不锈钢镶嵌橡胶圈 Stainless steel, soft seal for stainless steel Mozato rubber ring												
最高工作压力 Maximum working pressure	公称压力(注意ΔPmax及工作压力与工作温度的关系) Nominal pressure (Pay attention to ΔPmax And the pressure of work and working temperature relationship)												

执行器主要技术参数 Actuator main technical parameters

有效面积(cm²) Effective area	250		
压力设定范围(Mpa) Pressure setting range	0.01~0.12 0.08~0.25 0.2~0.5 0.45~1.0 0.6~2.0		
允许上下膜室之间最大压差(Mpa) Allow fluctuation membrane room between maximum differential pressure	0.4		
材质 Material quality	膜盖: 钢板镀锌; 膜片: EPDM或FKM夹纤维 Membrane cover: steel galvanized; diaphragm: EPDM or FKM clamp fiber		
控制管线、接头 The control line, joint	铜管或铜管10×1; 卡套式接头R1/4" Copper tube or pipe 10×1; Card sleeve joint R1/4"		

性能指标 Performance index

控制精度 Control accuracy	±4%		
允许泄漏量 (在规定试验条件下) Allow leakage (in the regulation test condition)	硬密封 Hard seal	4×10 ⁻⁶ 阀额定容量 4×10 ⁻⁶ valve rated capacity	
	软密封 Soft seal	DN15~50 10气泡/min 10 bubble/min	DN65~125 40气泡/min 40 bubble/min

允许压差 Allow differential pressure

公称通径(mm) Nominal diameter	15	20	25	32	40	50	65	80	100	125	150	200	250
最大允许压差 ΔP(MPa) Maximum allowable pressure difference Train	PN16		1.6					1.5		1.2		1.0	
最小允许压差 ΔP(MPa) Minimum allowable pressure difference train	PN40		2.0									1.0	
						0.08							

结构简图如下 Structure diagram below

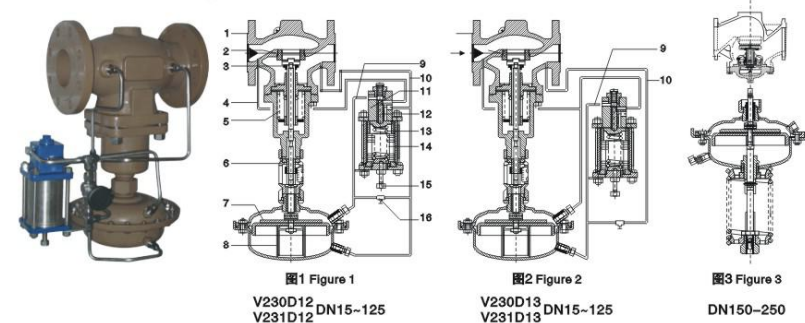

1 阀体 Body	2 阀座 Seat	3 阀芯 Valve core	4 阀前压力P1导压管 Valve front pressure P1 connecting pipe
5 平衡波纹管 Balanced bellows	6 行程显示件 Stroke display a	7 膜片 Diaphragm	8 弹簧 Spring
9 操作压力Ps导压管 Operating pressure Ps connecting pipe	10 阀后压力P2导压管 After the valve pressure P2 connecting pipe	11 指挥器 Command device	12 指挥器阀芯 Command device valve core
13 弹簧 Spring	14 波纹管 Bellows	15 调节螺钉 Adjusting screw	16 可调针阀 Adjustable needle valve

工作原理

指挥器操作型自力式压力调节阀由控制阀、执行器和指挥器组成，可分为阀后作用调节阀(如图1)和阀前作用调节阀(如图2)。
工作介质沿箭头所指方向流经调节阀，借助于导压管(4)将阀前压力P1传输到指挥器，依赖于设定调节螺钉(15)的调整，指挥器产生一个相应的操作压力Ps。
对于阀后作用调节阀，操作压力Ps作用于执行机构上膜室，设定压力(阀后压)P2作用于下膜室，并与指挥器反馈信号口相连。当设定压力P2上升，指挥器内弹簧(13)压缩量加大，使指挥器阀芯(12)向关闭方向(向下)移动，Ps值下降，这样，执行机构下膜室内P2增大，上膜室内Ps减少，导致调节机构阀芯向关闭方向移动，从而降低P2，直至恢复为原设定值。当P2下降时，作用方向与上述相反。
对于阀前作用调节阀，操作压力Ps作用于执行机构下膜室，设定压力(阀前压)P1作用于上膜室，阀前压力与指挥器反馈信号相连。当设定压力P1上升时，指挥器内弹簧(13)在P1作用下压缩，使指挥器阀芯(12)向关闭方向(向下)移动，Ps值下降，这样，执行机构下膜室内Ps减小，上膜室内P1增大，导致调节机构阀芯向开启方向移动，从而降低P1，直至恢复为原设定值。当P1下降时，作用方向与上述相反。
当现场设定阀后(或阀前)压力时，可通过调节螺钉(15)与针阀(16)来设定压力。

Working principle

Command device operational self type pressure regulating valve by valve and actuator and command device composition, can be divided into the valve after effect pressure regulating valve (figure 1) and valve before action pressure regulating valve (figure 2).
Working medium along the direction of arrow through pressure regulating valve, with the aid of connecting pipe (4) will valve front pressure P1 transmission to command device, depends on the set point adjusting screw (15) adjustment, command within the device A corresponding operating pressure Ps.
For the valve after effect pressure regulating valve, the operation pressure Ps role in actuators on membrane room, set pressure (valve after pressure) P2 role in the film chamber, and with the command unit feedback signal to the mouth. When setting Pressure P2 rise, command device for internal spring (13) compression quantity increase, make command device valve core (12) to close direction (down) mobile, Ps value decline, such, actuator film under indoor P2 increase, Membrane indoor Ps decreases, lead to the adjusting mechanism for the valve core to close direction, so as to reduce the P2, until the recovery for the original set point. When P2 declined, the effect direction and the above instead.
For the valve before action pressure regulating valve, the operation pressure Ps effect on actuator film under room, set pressure (valve former pressure) P1 effect on membrane room, valve front pressure and command unit feedback signal connected. When setting Pressure P1 rises, command device for internal spring (13) in P1 under the action of compression, make the command device valve core (12) to close direction (down) mobile, Ps value decline, such, actuator film under indoor Ps reduced, The film indoor P1 increase, resulting in the adjusting mechanism for the valve core to open direction, so as to reduce the P1, until the recovery for the original set point. When P1 declined, the effect direction and the above instead.
When the site after setting valve (or valve former) pressure, but through the adjusting screw (15) and needle valve (16) to set pressure.

选择时注意事项 When the choice the matters needing attention

参考直接作用式压力调节阀注意事项。Reference direct action pressure regulating valve attention.

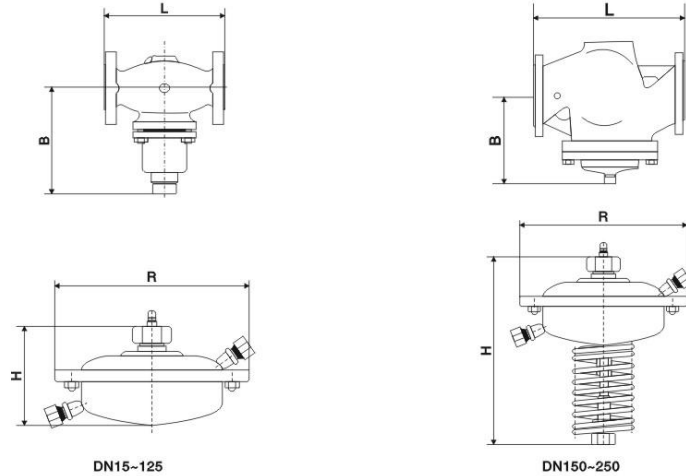

公称口径(mm) Nominal diameter	15	20	25	32	40	50	65	80	100	125	150	200	250
L(mm)	130	150	160	180	200	230	290	310	350	400	480	600	730
B(mm)	121	212	238	238	240	240	275	275	380	380	295	325	372
ΦR(mm)	263												
H(mm)	150												
大约重量(kg) About weight	20.2	20.7	23.7	27	28	32	43	47	74	84	98	158	238

订货时须提出下列条件

- ① 产品型号
- ② 公称口径
- ③ 公称压力
- ④ 法兰标准
- ⑤ 压力设定范围
- ⑥ 阀体材料
- ⑦ 介质种类及工作温度
- ⑧ 有无特殊要求

When placing order, please put forward the following conditions

- ① The product model
- ② The nominal diameter
- ③ Nominal pressure
- ④ The flange standards
- ⑤ Pressure setting range
- ⑥ Body material
- ⑦ Medium type and working temperature
- ⑧ Have special requirements

应用简例 Application Jane cases

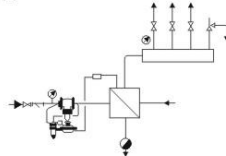

蒸汽发生器的压力控制
Steam generator pressure control

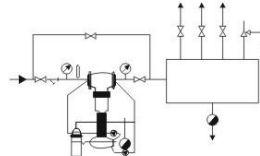

分气缸的压力控制
Points of cylinder pressure control

自力式流量调节阀主要用于工艺过程控制中的恒流量调节。例如城市供热，供暖系统的中心站流量控制，各分站的流量控制以及各控制系统的流量控制网络，可用于最高温度200℃的非腐蚀性的液体介质。

Self type flow control valve is mainly used in process control of constant flow control. For example city heating, heating system is the center of the flow control, the substation of flow control and the control system flow control network, and can be used for the highest temperature 200 °C of non corrosive liquid medium.

型号 Model

流量调节阀: V130D05 (硬密封) V131D05(软密封)
Flow control valve: V130D05 (hard seal) V131D05 (soft seal)

控制阀主要技术参数 Control valve main technical parameters

公称口径(mm) Nominal diameter	15	20	25	32	40	50	65	80	100	125	150	200	250	
额定流量系数Kvs Rated flow the most coefficient	4	6.3	8	16	20	32	50	80	125	160	280	320	400	
公称压力(MPa) Nominal pressure	1.6;4.0													
有效压力下最大流量(m ³ /h) Effective pressure under the maximum flow	0.02MPa	1.5	2.5	3.5	5.5	9.0	14	22	36	55	70	125	180	250
	0.05MPa	2.5	3.5	5.5	9.0	12	22	36	55	85	110	180	-	-
噪音衡量系数Z值 Noise measure coefficient Z value	0.6	0.6	0.6	0.55	0.55	0.5	0.5	0.45	0.4	0.35	0.3	0.2	0.2	
最高工作温度(℃) Maximum operating temperature	≤140													
	硬密封配隔离罐 ≤200 Hard seal with isolation tank ≤200										配隔离罐加长件 ≤200 With isolation tank extensions ≤200			
压力平衡元件 Pressure balance element	波纹管 Bellows 滚动膜片 Rolling diaphragm													
法兰标准 Method orchid scale must	ANSI、JIS、DIN、GB、JB(特殊可按用户提供 Special according to users)													
阀体材质 Valve body material quality	铸铁; 铸钢; 铸不锈钢 Cast Iron; Cast steel; Cast stainless steel													
阀芯材质 Valve core material	不锈钢, 软密封为不锈钢镶嵌橡胶圈 Stainless steel, soft seal for stainless steel Mosaic rubber ring													
最高工作压力 Maximum working pressure	公称压力(注意ΔPmax及工作压力与工作温度的关系) Nominal pressure (Pay attention to ΔPmax And the pressure of work and working temperature relationship)													

执行器主要技术参数 Actuator main technical parameters

有效面积(cm ²) Effective area	250	630
有效压力 (MPa) Effective pressure	0.02; 0.05	
允许上下膜室之间压差(MPa) Allow fluctuation film pressure difference between the chamber	0.4	0.15
材质 Material	膜盖: 钢板镀锌; 膜片: EPDM或FKM夹纤维 Membrane cover: steel galvanized; diaphragm: EPDM or FKM clamp fiber	
控制管径、接头 The control line, joint	铜管或钢管10x1;卡套式接头R1/4" Copper tube or pipe 10×1, Cutting sleeve type Joint R1/4"	

注: 有效压力: 指节流板前后的差压, 表中有效压力下的最大流量只适用于水, 其它介质需通过公式换算。Note: effective pressure: refers to the throttle plate and differential pressure, table effective pressure of the maximum flow is only applicable to water, and other medium should be through the formula conversion.

性能指标 Performance index

控制精度(%) Control accuracy	±5%		
允许泄漏量 (在规定的试验条件下) Allow leakage (In the regulation test conditions)	硬密封 Hard seal	4×10 ⁻⁴ 阀额定容量 4×10 ⁻⁴ valve rated capacity	
	软密封 Soft seal	DN15-50	DN65-125
		10气泡/min 10 bubble/min	20气泡/min 20 bubble/min

允许压差 Allow differential pressure

公称口径(mm) Nominal diameter	15	20	25	32	40	50	65	80	100	125	150	200	250
最大允许压差 ΔP(MPa) Maximum allowable pressure difference	PN16	1.6											
	PN40	2.0											

1	限流器 Current limiter
2	阀体 Body
3	阀座 Seat
4	阀轴 Valve shaft
5	阀瓣 Valve oap
6	充注阀 Filling valve
7	驱动器外壳 Drive shell
8	压制膜片 Pressing diaphragm
9	波纹管 Bellows

一定流量的介质经过限流器时引起压差，压差通过脉冲管作用在控制膜片上。通过内置的控制弹簧限制压差(限流器压差)和流量。
Must flow of the medium through current limiter caused differential pressure, differential pressure through the pulse tube effect in the control on the diaphragm. Through the built-in control spring limited differential pressure (current limiter differential pressure) and flow.

工作原理

被控介质输入阀以后，阀前压力P1通过控制管线输入下膜室，经节流阀节流后的压力Ps输入上膜室。P1与Ps的差即 $\Delta P = P1 - Ps$ 称为有效压力。P1作用在膜片上产生的推力与Ps作用在膜片上产生的推力差与弹簧反力相平衡确定了阀芯与阀座的相对位置，从而确定了流经阀的流量。当流经阀的流量增加时，即 ΔP 增加，结果P1、Ps分别作用在下、上膜室，使阀芯向阀座方向移动，从而改变了阀芯与阀座之间的流通面积，使Ps增加，增加后的Ps作用在膜片上的推力加上弹簧反力与P1作用在膜片上的推力在新的位置产生平衡达到控制流量的目的。反之，同理。

设定被控介质的流量用调整节流阀与阀座的相对位置来确定。

Working principle

Accused of medium after input valve, valve pressure before P1 Through the control line input of the film chamber, After the throttle valve throttle pressure Ps input film chamber. P1 and Ps Difference is $\Delta P = P1 - Ps$ Called effective pressure. P1 The role of the diaphragm and the thrust produced by Ps Action in the diaphragm on the thrust produced by the difference and spring reaction phase equilibrium determined the valve core and valve seat of the relative position, To determine the flow through the valve. When the flow through the valve increases, namely ΔP increase, The results P1、Ps Role respectively in、On film chamber, The valve core to seat direction, So as to change the valve core and valve seat between the circulation area, make Ps increase, Increase after the Ps Action in the diaphragm on the thrust and spring reaction and P1 Action in the diaphragm on the thrust in the new position produce balance to achieve the purpose of control flow. and, By the same token.

Set was accused of medium flow with adjustment throttle valve and valve seat to determine the relative position.

选择时注意事项

- ① 主要应用在被控流量一旦调定后，不经常改变(调整)的场合。
 - ② 流量阀的有效压力分为0.02MPa和0.05MPa两种，应根据实际情况选用，选取时阀前后压差要大于该有效压力。
 - ③ 调节时，参照校准图和流量计，调节节流阀至所需控制的流量值。
 - ④ 安装示意图
- 参考直接作用式压力调节阀的安装示意图，并加装流量计。

When the choice the matters needing attention

- ① is mainly used in control flow once set-up, often do not change (adjust) occasions.
 - ② the flow valve effective pressure is divided into 0.02 MPa and 0.05 MPa two kinds, should be chosen according to the practical situation, the differential pressure of the valve before and after more than the effective pressure.
 - ③ regulation, reference calibration chart and flowmeter, regulate the throttle valve to the necessary control flow value.
 - ④ Installation plan
- Reference direct action pressure control valve installation plan, and equipped with meter.

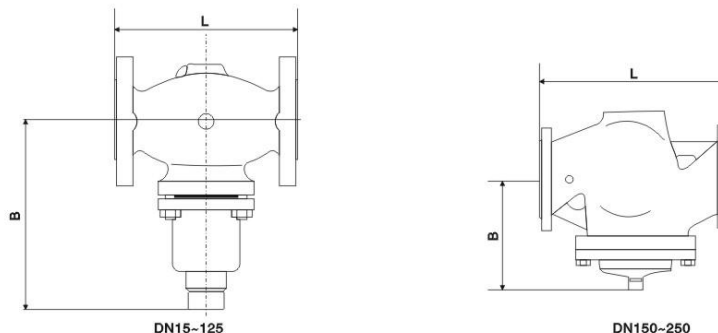

外形尺寸及重量 Physical size and weight

控制阀尺寸及重量 Control valve size and weight

公称直径(mm) Nominal diameter	15	20	25	32	40	50	65	80	100	125	150
L(mm)	130	150	160	180	200	230	290	310	350	400	480
B(mm)	212	212	238	238	240	240	275	275	380	380	295
大约重量(kg) About weight	6.2	6.7	9.7	9.7	14	17	29	33	60	70	80

执行器尺寸及重量 Actuator size and weight

有效面积cm ² Effective area	32	80	250	630
ΦR(mm)	172	172	263	380
H(mm)	435	430	470	520
大约重量(kg) About weight	7.5	7.5	13	28

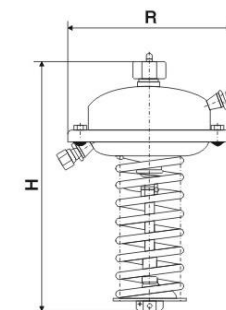

订货时须提出下列条件

- ① 产品型号
- ② 公称口径
- ③ 公称压力
- ④ 阀体材料
- ⑤ 压力设定范围
- ⑥ 法兰标准
- ⑦ 介质种类及工作温度
- ⑧ 有无特殊要求

When placing order, please put forward the following conditions

- ① The product model
- ② The nominal diameter
- ③ Nominal pressure
- ④ The valve body material
- ⑤ Pressure setting range
- ⑥ Flange standards
- ⑦ Medium type and working temperature
- ⑧ Have special requirements

应用简例 Application Jane cases

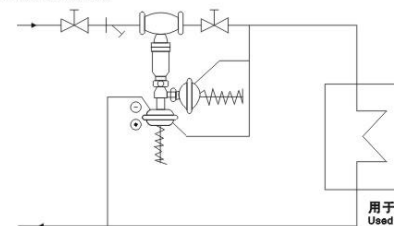

用于压力、差压控制场合
Used for pressure, differential pressure control occasions

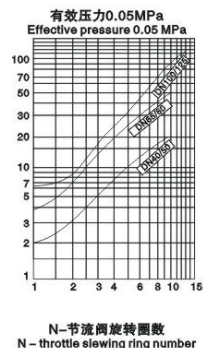
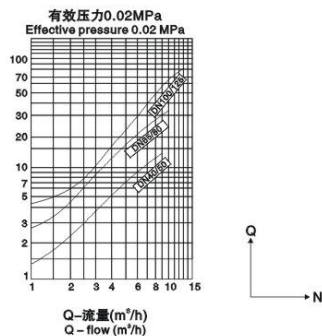

订货时须提出下列条件

- ① 产品型号 ② 公称口径 ③ 公称压力 ④ 有效压力及有效面积 ⑤ 法兰标准 ⑥ 阀体材料 ⑦ 介质种类及工作温度 ⑧ 有无特殊要求

When placing order, please put forward the following conditions

- ① the product model ② the nominal diameter ③ nominal pressure ④ the effective pressure and effective area ⑤ standard flange ⑥ body material ⑦ medium type and working temperature ⑧ have special requirements

应用简例 Application Jane cases

供水安装 Water supply installation

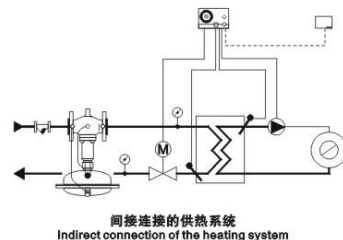
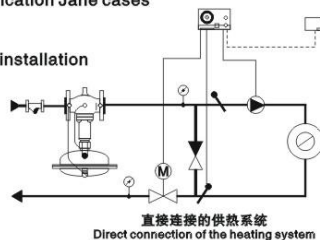

回水安装 Backwater installation

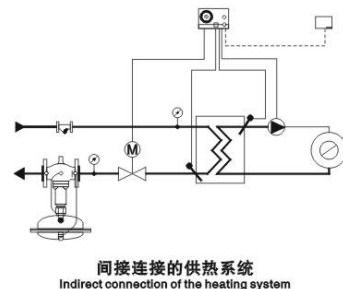
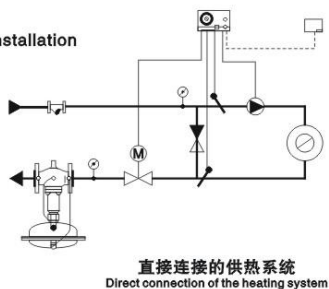

自力式压力、差压组合阀主要应用于工艺过程控制中的压力和差压调节,可用于最高温度300℃的非腐蚀性的液体、气体和蒸汽等介质,按优先动作原理工作,不能同时控制两个参数。

Self type pressure, differential pressure combination valve is mainly used in process control of pressure and differential pressure control, can be used for the highest temperature 300°C noncorrosive liquids, gases and steam, and other media. According to the priority action principle work, cannot at the same time control two parameters.

型号 Model

V230D01D03(硬密封) V231D01D03(软密封)
V230D01D03 (hard seal) V231D01D03 (soft seal)

控制阀主要技术参数 Control valve main technical parameters

公称口径(mm) Nominal diameter	15	20	25	32	40	50	65	80	100	125	150	
额定流量系数Kvs Rated flow coefficient	4	6.3	8	16	20	32	50	80	125	160	280	
噪声衡量系数Z值 Noise measure coefficient Z value	0.6	0.6	0.6	0.55	0.55	0.5	0.5	0.45	0.4	0.35	0.3	
公称压力(MPa) Nominal pressure	1.6; 4.0											
最高工作温度(℃) Maximum operating temperature	液体 ≤140; 气体 ≤80 Liquid ≤140; Gas ≤80											
	硬密封 Hard seal	配隔离罐 ≤200 With isolation tank ≤200								配隔离罐加长件 ≤300 With isolation tank extensions ≤300		
压力平衡元件 Pressure balance element	波纹管 Bellows										滚动膜片 Rolling diaphragm	
法兰标准 Flange standards	ANSI, JIS, DIN, GB, JB(特殊可按用户提供 Special according to users)											
阀体材质 Body material	铸铁; 铸钢; 铸不锈钢 Cast iron; Cast steel; Cast stainless steel											
阀芯材质 Valve core material	不锈钢, 软密封为不锈钢镶嵌橡胶圈 Stainless steel, soft seal for stainless steel Mosalco rubber ring											
最高工作压力 Maximum working pressure	公称压力(注意 ΔPmax 及工作压力与工作温度的关系) Nominal pressure (Pay attention to ΔPmax And the pressure of work and working temperature relationship)											

执行器主要技术参数 Actuator main technical parameters

有效面积(cm ²) Effective area	32※	80※	250	630
压力设定范围(MPa) Pressure setting range	0.8~1.6	0.1~0.6	0.015~0.15	0.005~0.035
	0.3~1.2	0.05~0.3	0.01~0.07	
允许上下膜室之间最大压差(MPa) Allow fluctuation membrane room between maximum differential pressure	3.0	1.25	0.4	0.15
材质 Material	膜盖: 钢板镀锌; 膜片: EPDM或FKM夹纤维 Membrane cover: steel galvanized; Diaphragm: EPDM or FKM clamp fiber			
控制管线、接头 The control line, joint	铜管或钢管 10×1: 卡套式接头 R1/4" Copper tube or pipe 10×1: cutting sleeve type joint R1/4"			

注: ※DN150不能满足该设定值 Note: 6 later can't satisfy the set value

性能指标 Performance index

控制精度 Control accuracy	±8%		
允许泄漏量 (在额定试验条件下) Allow leakage (in the regulation test conditions)	硬密封 Hard seal	4×10 ⁻⁴ 阀额定容量 4×10 ⁻⁴ valverated capacity	
		DN15~50	DN65~125
	软密封 Soft seal	10气泡/min 10 bubble/min	20气泡/min 20 bubble/min

允许压差 Allow differential pressure

公称口径(mm) Nominal diameter	15	20	25	32	40	50	65	80	100	125	150
最大允许压差 ΔP(MPa) Maximum allowable pressure difference	PN16	1.6						1.5			
	PN40	2.0						1.2			

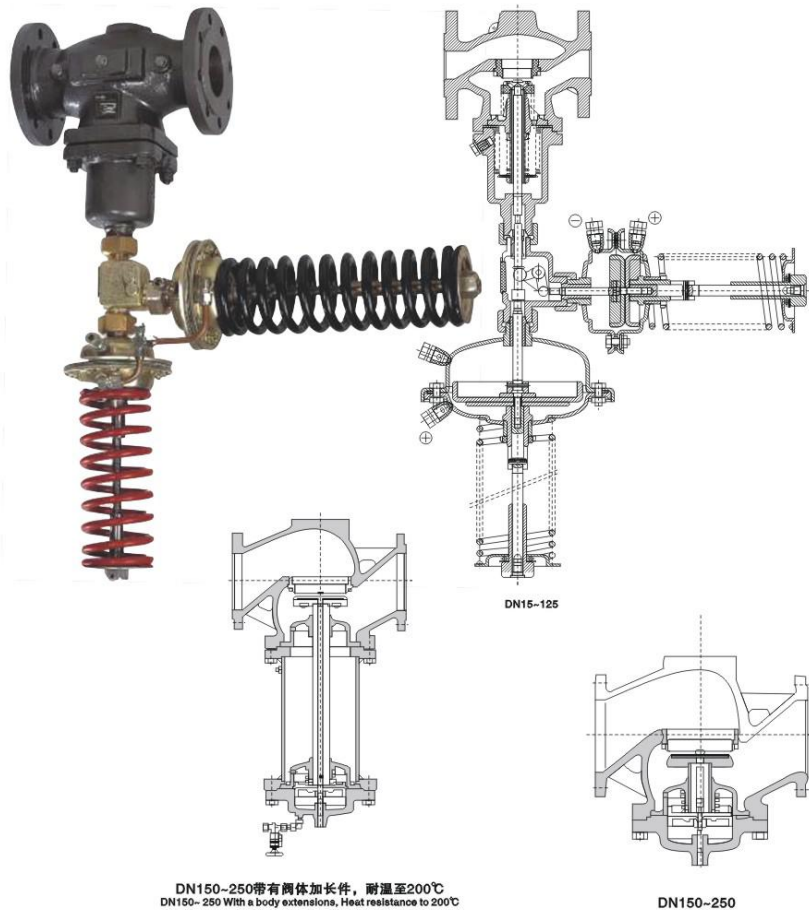

DN150-250带有阀体加长件, 耐温至200℃
DN150-250 With a body extensions, Heat resistance to 200°C

DN150-250

工作原理

参照压力调节阀的工作原理。

Working principle

With reference to the working principle of pressure regulator.

选择时注意事项

参照压力调节阀的选择注意事项。

When the choice the matters needing attention

Reference pressure regulating valve choice note.

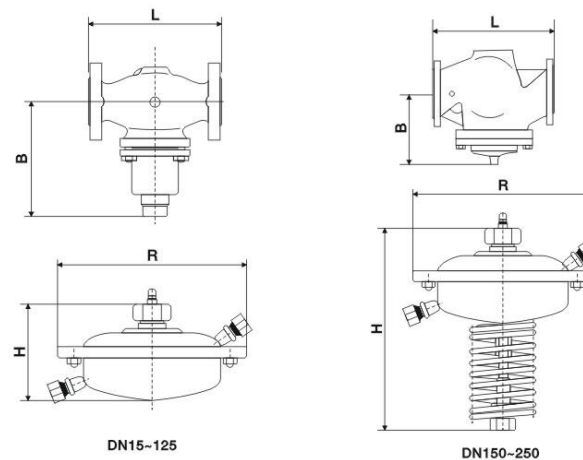

DN15-125

DN150-250

外形尺寸及重量 Physical size and weight

公称直径(mm) Nominal diameter	15	20	25	32	40	50	65	80	100	125	150	200	250
L(mm)	130	150	160	180	200	230	290	310	350	400	480	600	730
B(mm)	121	212	238	238	240	240	275	275	380	380	295	325	372
ΦR(mm)	150										380		
H(mm)	263										520		
大约重量(kg) About weight	21	23	24	27	31	36	47	55	74	93	118	178	261

校准图: 为更准确、快速调定阀的流量, 提供以下校准图供用户参考(如需更精确设定流量或公称通径DN150-250的阀门设定流量时, 应采用流量计测量)本校准图只适用于水, 其它介质可参考该图, 并在实际流程中进行适当调整。

Calibration graph: for more accurate and rapid setting valve flow, provide the following calibration chart for the user reference (if you need more accurate setting flow or nominal diameter DN150-250 Valve set flow should be used when flowmeter measurement) this calibration chart is only applicable to water, and other media may refer to a linear, and in the actual process of adjustment.

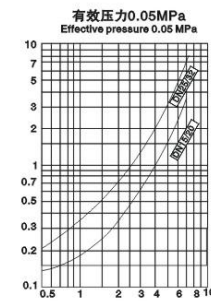
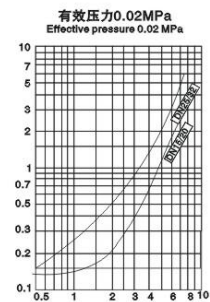

自力式流量、温度组合阀主要应用于供热、供暖系统中的流量和温度的调节，可用于最高温度200℃的非腐蚀性的液体等介质，按优先动作原理，不能同时控制两个参数。

Self type flow, temperature combination valve is mainly applied in heating, heating system, the flow and temperature control, can be used for the highest temperature 200℃ noncorrosive liquids, and other media, according to priority Action principle, cannot at the same time control two parameters.

型号 Model

类别 Category	流量、温度组合阀(温度升高关闭) Flow, temperature combination valve (temperature valve shut)			
	控制液体温度 Control liquid temperature		控制液体或气体温度 Control the liquid or gas temperature	
	硬密封 Hard seal	软密封 Soft seal	硬密封 Hard seal	软密封 Soft seal
型号 Model	V130D05T06	V131D05T06	V130D05T17	V131D05T17

控制阀主要技术参数 Control valve main technical parameters

公称口径(mm) Nominal diameter	15	20	25	32	40	50	65	80	100	125	150	
额定流量系数Kvs Rated flow coefficient	4	6.3	8	16	20	32	50	80	125	160	280	
有效压力下最大流量(m ³ /h) The most effective pressure Mass flow	0.02MPa	1.5	2.5	3.5	5.5	9.0	14	22	36	55	70	125
	0.05MPa	2.5	3.5	5.5	9.0	12	22	36	55	85	110	180
公称压力(MPa) Nominal pressure	1.6; 4.0											
最高工作温度(℃) Maximum operating temperature	≤140											
	硬密封配隔离罐≤200 Hard seal with isolation tank≤200											
压力平衡元件 Pressure balance element	波纹管 Bellows											
法兰标准 Flange standards	ANSI, JIS, DIN, GB, JB(特殊可按用户提供 Special according to users)											
阀体材质 Body material	铸铁; 铸钢; 铸不锈钢 Cast iron, cast steel, cast stainless steel											
阀芯材质 Valve core material	不锈钢, 软密封为不锈钢嵌橡胶圈 Stainless steel, soft seal for stainless steel Mosalco rubber ring											
最高工作压力 Maximum working pressure	公称压力(注意ΔPmax及工作压力与工作温度的关系) Nominal pressure (Pay attention to ΔPmax And the pressure of work and working temperature relationship)											

执行器主要技术参数 Actuator main technical parameters

有效面积(cm ²) Effective area	250	630
有效压力(MPa) Effective pressure	0.02; 0.05	
允许上下膜室之间压差(MPa) Allow fluctuation film pressure difference between the chamber	0.4	0.15
材质 Material	膜盖: 钢板镀锌; 膜片: EPDM或FKM夹纤维 Membrane cover: steel galvanized; Diaphragm: EPDM or FKM clamp fiber	
控制管线、接头 The control line, joint	铜管或铜管10×1; 卡套式接头R1/4" Copper tube or pipe 10×1; Cutting sleeve type joint R1/4"	

T06、T17执行器主要技术参数 T06、T17 actuator main technical parameters

执行器型号 Executive shape	T06	T17
温度设定范围(℃) Temperature setting range	~20~50 20~90	40~110 60~130
特殊温度设定(℃) Special temperature setting	110~180 180~250	
超温保护 Overtemperature protection	超过设定值100℃以内 More than 100℃ within the set value	
时间常数(S) Time constant	120	20
温包材质 Bulb material	铜镍镍 Copper nickel plating	
毛细管长度(m) Capillary length	5,10,15, (根据用户要求提供 According to user requirements to provide)	

性能指标 Performance index

允许泄漏量 (在规定的试验条件下) Allow leakage (In the regulation test conditions)	硬密封 Hard seal	4 × 10 ⁻⁴ 额定容量 4 × 10 ⁻⁴ valve rated capacity		
	软密封 Soft seal	DN15~50	DN65~125	DN150
	10气泡/min 10 bubble/min	20气泡/min 20 bubble/min	40气泡/min 40 bubble/min	

结构简图如下 Structure diagram below

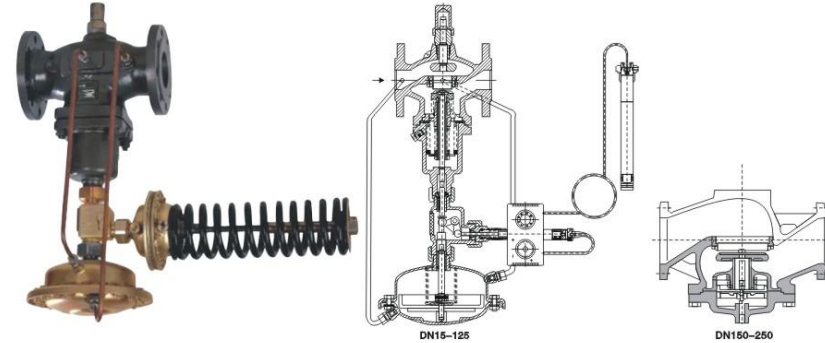

允许压差 Allow differential pressure

公称口径(mm) Nominal diameter	15	20	25	32	40	50	65	80	100	125	150
最大允许压差ΔP(MPa) Maximum allowable pressure difference	PN16	1.6								1.5	0.5
	PN40	2.0									

工作原理

参照流量调节阀与温度调节阀的工作原理。

外形尺寸及重量

参考流量阀与温度阀的外形尺寸及重量

校准图

参考流量阀的校准图

Working principle

Reference flow control valve and the working principle of the temperature control valve.

Physical size and weight

Reference flow valve and temperature valve shape size and weight

Calibration chart

Reference flow valve calibration chart

应用简例 Application Jane cases

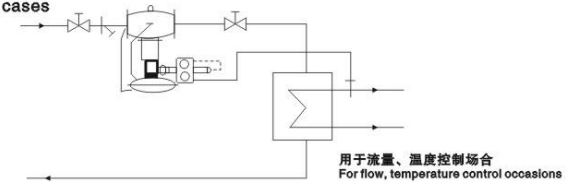

订货时应详细说明以下条件

- ①产品型号 ②公称口径 ③公称压力 ④阀体材料 ⑤温度设定范围或毛细管长度
- ⑥法兰标准 ⑦介质种类及工作温度 ⑧是否有其它特殊要求

When you place an order should detail the following condition

- ① The product model ② The nominal diameter ③ Nominal pressure ④ The valve body material ⑤ Temperature setting range or capillary length
- ⑥ Flange standards ⑦ Medium type and working temperature ⑧ of whether any other special requirements

其它组合方式

自力式调节阀的组合方式，除了以及所述的两种方式外，还可根据不同工艺情况下的控制要求，通过组合件，按优先动作原理任意组合。如压力温度组合阀、差压温度组合阀、压力流量组合阀、差压流量组合阀、温度温度组合阀等，还可与电动阀配用，如电动温度组合控制等。组合后的调节阀所需型号及参数参考前面所述。

Other combinations

Self type valve combination, in addition to and mentioned two ways outside, still can according to different process under control requirements, through the assembly, according to the priority action principle arbitrary combination. Such as pressure and temperature combination valve, differential pressure temperature combination valve, pressure flow combination valve, differential pressure flow combination valve, temperature temperature combination valve and so on, also with electric valve with, such as electric temperature combination control and so on. After the combination of the regulating valve required model and parameters reference mentioned.

应用简例 Application Jane cases

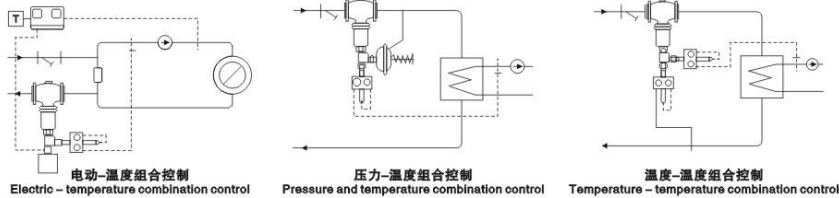

附件

- ① 隔离罐：用于液体温度超过140℃，气体温度超过80℃时，安装在控制管线上，灌入冷媒，防止膜片老化。(如图1)
- ② 散热器：用于温度超过200℃时，一般与隔离罐同时使用(温度阀除外)。(如图2)
- ③ 行程显示件 (如图3)
- ④ 组合件：用于多项控制，例如：流量、温度组合，按优先动作原理工作，但不能同时控制两个参数。(如图4)

Accessories

- ① the isolation tank: used for liquid temperature more than 140℃, the gas temperature more than 80℃, installed in the control line, penetration refrigerant, prevent diaphragm aging. (figure 1)
- ② the radiator: used for temperature more than 200℃, the general and isolation tank used at the same time (temperature valve except). (figure 2)
- ③ stroke display (as shown in figure 3)
- ④ the assembly: used for a number of control, such as flow, temperature combination, according to the priority action principle work, but not at the same time control two parameters. (as shown in figure 4)



图1 Figure 1



图2 Figure 2

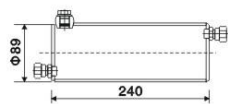

图3 Figure 3

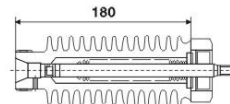

图4 Figure 4

- ⑤ 加长件：用于温度超过140℃时，灌入冷水，防止膜片老化。(如下图)
- ⑥ extensions: used for temperature more than 140℃, into cold water, prevent diaphragm aging. (below chart)

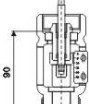

DN150

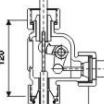
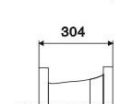
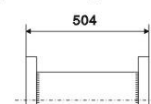

DN200



DN250

概述

ZZYP型自力式压力调节阀是不需要任何外加能源，利用被调介质自身能量而实现自动调节的执行器产品，该产品最大特点是能在无电、无气的场所工作，同时又节约了能源，压力设定值在运行中可随意调整。采用快开流量特征，动作灵敏、密封性能好，因而它广泛应用于石油、化工、电力、冶金、食品、轻纺、机械制造与居民建筑楼群等各种工业设备中各种气体、液体及蒸汽介质减压、稳压（用于阀后调节），或泄压、持压（用于阀前调节）的自动控制。附设冷凝器可在≤350℃温度下使用。

产品符合GB/T4213-1992。

Overview

ZZYP type self type pressure regulator is don't need any applied energy, the use of modulated medium self-energy and realize automatic adjustment of the actuator product, the product the biggest characteristic is to can be in no Electricity, airless place work, at the same time and save energy, in the operation of the pressure setting can be adjusted freely. The quick opening flow characteristics, action is sensitive, sealed performance is good, so it is widely used in petroleum, chemical, electric power, metallurgy, food, textile, machinery manufacturing and residents building blocks, etc. Various kinds of industrial equipment of gas, liquid and steam medium decompression, voltage regulator (for valve after adjustment Section), or pressure, the pressure (used in front of the regulation) automatic control. Attached condenser can be in ≤350℃ Temperature using.

Products comply with GB/T4213-1992.

主要技术参数和性能指标 The main technical parameters and performance index

1. 主要技术参数 Main technical parameters

公称口径(mm) Nominal diameter	20	25	32	40	50	65	80	100	125	150	200	250	300	
额定流量系数(Kv) Rated flow coefficient	7	11	20	30	48	75	120	190	300	480	760	1100	1750	
额定行程(mm) Rated stroke	8		10		14		20		25		40		70	
公称压力(MPa) Nominal pressure	1.6、4.0、6.4													
压力调节范围(KPa) Pressure regulating range	15-50 40-80 60-100 80-140 120-180 160-220 200-260 240-300 280-350 330-400 380-450 430-500 480-560 540-620 600-700 680-800 780-900 880-1000 600-1500 1000-2500													
流量特性 Flow characteristic	快开 Quick opening													
调节精度(%) Control accuracy	±5													
使用介质 Working medium	热水、蒸汽、各种气体及低粘度介质 Hot water, steam, all kinds of gas and low viscosity medium													
使用温度(℃) Using temperature	-20-80、-20-350													
允许泄漏量 Allow leakage	硬密封(ml/h) Hard seal	单座: ≤10 ⁻⁴ 阀额定容量 (Ⅳ级); 双座、套筒: ≤5×10 ⁻⁴ 阀额定容量 (Ⅱ级) Single seat: ≤10 ⁻⁴ Valve rated capacity (Ⅳ level); Two seat/sleeve: ≤5×10 ⁻⁴ Valve rated capacity (Ⅱ level)												
	软密封(ml/h) Soft seal	0.15	0.30	0.45	0.60	0.90	1.7	4.0	6.75	11.10	11.60			
减压比 Decompression ratio	最大 maximum	10												
	最小 minimum	1.25												

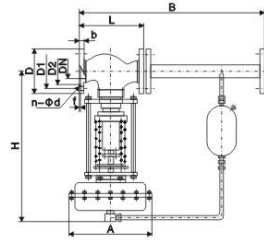

外形尺寸与重量 Physical size and weight

公称直径(mm) Nominal diameter	20	25	32	40	50	65	80	100	125	150	200	250	300
法兰接管尺寸B Flange over size	383		512		603	862		1023	1380		1800	2000	2200
法兰端面距L Flange face distance	181	184	200	222	254	276	298	352	410	451	600	650	740
压力调节范围 Kpa	15-140	H	475	520		540	710	780	840	880	915	940	1000
		A	280	308									
	130-300	H	455	500		520	690	760	800	870	880	900	950
		A	230										
	280-500	H	450	490		510	680	750	790	860	870	890	940
		A	176										194
	480-1000	H	445	570		600	820	890	950	1000	1100	1200	
		A	176										194
	600-1500	H	445	570		600	820	890	950	1000	1100	1200	
		A	85										96
	1000-2500	H	445	570		600	820	890	950	1000	1100	1200	
		A	85										96
重量kg weight	26		37		42	72	90	114	130	144	180	200	250
导压管接头螺纹 Connecting pipe joint thread	M16×1.5												

主要零件材料 The major parts material

零件名称 Part name	材料 Wood material
阀体 Valve body	WCB、ZG1Cr18Ni9Ti、ZGCr18Ni12Mo2Ti
阀芯 Valve core	1Cr18Ni9Ti、Cr18Ni12Mo2Ti
阀座 Seat	1Cr18Ni9Ti、Cr18Ni12Mo2Ti
阀杆 Stem	1Cr18Ni9Ti、Cr18Ni12Mo2Ti
橡胶膜片 Rubber diaphragm	丁腈、乙炔、氟、耐油橡胶 Nitrile, ethylene, fluorine, oil resistant rubber
膜盖 Membrane cover	A3、A4钢涂四氟乙烯 A3, A4 steel coated tetrafluoroethylene
填料 Packing	聚四氟乙烯、柔性石墨 Teflon, flexible graphite

订货须知

订货时请填写《规格书》或详细说明以下内容:

- 1、产品型号 2、公称直径 3、公称压力 4、额定流量系数KV 5、阀前压力 6、阀后压力 7、阀体、阀芯材料 8、使用介质
- 9、介质温度 10、控制方式

Order instructions

When ordering, please fill in 《specification》 or specify the following contents:

- 1、the product model 2、nominal diameter 3、nominal pressure 4、rated flow coefficient KV 5、valve front pressure 6、valve pressure after 7、the valve body, valve core material 8、use medium 9、medium temperature 10、control mode

特点和用途

ZZYPR-16B软密封自力式阀后压力调节阀(以下简称调压阀)是利用被调介质自身的压力的变化来驱动执行机构,从而达到自动稳定阀后压力的目的。

可以广泛地应用于各类弱腐蚀常温介质的压力调节场合。特别适用于天然气、煤气等气体的减压稳压调节。

特点:(1)阀芯为平衡型单座结构,不平衡力小,调节灵敏;(2)阀芯为软密封结构,可达到严密型关闭;(3)结构紧凑,安装方便;(4)调试及维修方便。

Characteristics and USES

ZZYPR-16B soft seal self type valve after pressure regulator (hereinafter referred to as the pressure regulating valve) is the use of modulated medium their stress changes to drive actuator, so as to achieve automatic stable after the valve The purpose of the pressure.

Can be widely used in all kinds of weak corrosion cold medium pressure regulation occasion. Especially suitable for natural gas, gas and gas pressure relief stabilized voltage regulation.

Characteristics: (1) the valve core to balance type single seat structure, not smooth force is small, adjust sensitive; (2) the valve core for soft seal structure, can achieve close type shut; (3) the structure is compact, easy installation, (4) regulating The school and convenient maintenance.

主要技术参数 Main technical parameters

公称压力(MPa) Nominal pressure	1.6MPa
阀后压力调节范围 After the valve pressure regulating range	15-60KPa 50-200KPa 120-400KPa 300-1000KPa
压力调节精度 Pressure regulation precision	8%
使用温度 Use humidity	-10℃~+80℃
流量调节范围 Flow regulating range	2%~90%
关闭时泄漏率 Closing leakage rate	GB/T 4213-92 VI级 VI level
法兰标准 Flange standards	JB79-59

结构及动作原理

调压阀主要结构见图一。

当介质经阀体流出,阀后的压力经反馈管反馈至执行机构膜片上方,产生推力,与平衡弹簧的设定力平衡,阀芯就稳定在与阀后压力对应的开度上。当阀后的压力变化时,经反馈,阀芯的开度也相应变化,使阀后的压力始终保持恒定的输出。同样,当改变平衡弹簧的设定力时,阀后的压力也会相应变化,所以旋动压力调节螺母,就可以方便地调出所需的压力。

The structure and operating principle

Pressure regulating valve main structure see fig.1.

When the medium body outflow, valve pressure after the feedback tube feedback to actuator diaphragm above, produce thrust, and balance spring setting force balance, valve core is stable in and after valve pressure on The opening should be on. When the valve after the pressure change, the feedback, valve core opening also corresponding change, make the valve after the pressure always keep constant output. Likewise, when change the balance spring setting force When, after the valve pressure will also corresponding change, so turn the pressure adjusting nut, it can be convenient to tune out the pressure.

调压阀的系列参数及外形尺寸 Pressure regulating valve series of parameters and external dimensions

公称直径(mm) Nominal diameter	20	25	40	50	65	80	100	150	200		
阀座直径 Seat diameter	20	25	32	40	50	65	80	100	125	150	200
流量系数KV Flow coefficient	6.3	10	16	25	40	63	100	160	250	400	630
L	181	184	222		254	276	298	352	451	600	
	H1	52.5	57.5	72.5	80	90	97.5	107.5	140	167.5	
H	430	438	458		470	730	740	750	880	980	
ΦA 调压范围	15-60	ZMYA-5 Φ325					ZMYA-6 Φ362				
	50-200	ZMYA-4 Φ230					ZMYA-5 Φ325				
	120-400	ZMYA-3 Φ180					ZMYA-4 Φ230				
	300-1000	ZMYA-1 Φ120					ZMYA-4 Φ150				

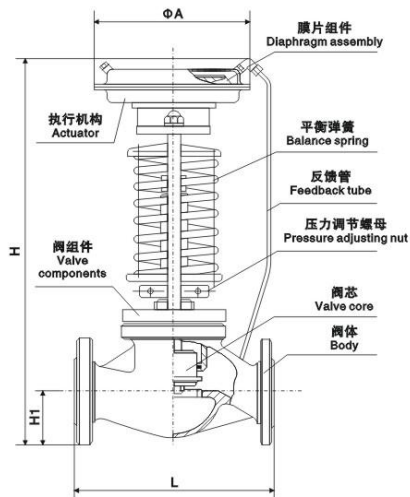

调压阀的主要零件材质 Pressure regulating valve of the main materials of parts

零件名称 Part name	材料 Material
阀体 Valve body	ZG230-450, ZG1Cr18Ni9
阀芯 Valve core	1Cr18Ni9
阀座 Seat	1Cr18Ni9
密封圈 Seal	丁腈橡胶 Nitrile rubber
膜片 Diaphragm	丁腈橡胶夹增强涤纶织物 Nitrile rubber clamp enhance terylen fabric
弹簧 Spring	60Si2MnA
导向套 Guide sleeve	HPb59-1

调压阀的安装

- 1、调压阀在安装以前必须对管道进行彻底的冲洗，不得有杂物，条件允许，建议在阀前装一过滤器。
- 2、调压阀一般应正立安装在管道上，且介质流向应与阀体上的箭头一致。
- 3、调压阀一般应配置旁路，以便应急和维修。

Pressure regulating valve installation

- 1、pressure regulating valve in the installation must be used to conduit rinse thoroughly, can not have sundry, conditions allow, the proposal in the valve front loading a filter.
- 2、pressure regulating valve should be generally are made installed in the pipeline, and the flow direction of medium and the arrow on the valve body shall be consistent.
- 3、pressure regulating valve should be generally configuration bypass, so that emergency and maintenance.

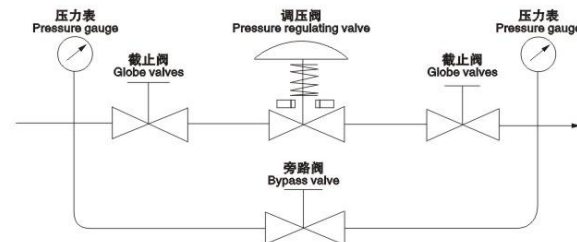

调压阀的安装

- 1、调压阀在安装以前，必须对管道进行彻底冲洗，不得有杂物。条件允许，建议在阀前加装过滤器。
- 2、调压阀一般应正立安装于管道上，并且介质的流向应与阀体上的箭头一致。
- 3、调压阀一般应配置旁路，以便应急和维修。

Pressure regulating valve installation

- 1、pressure regulating valve in installation ago, must to conduit rinse thoroughly, can not have sundry. The condition allows, the proposal in the valve before adding filter.
- 2、pressure regulating valve should be generally are made installed on the pipeline, and the flow of medium should be consistent with the arrow on the valve body.
- 3、pressure regulating valve should be generally configuration bypass, so that emergency and maintenance.

调压阀的调试及保养

- 1、调试前应检查安装是否正确
- 2、调试时，先关闭旁路阀，然后分别打开阀后及阀前的截止阀。转动调压阀上的调节手轮，并观察阀后压力表，直至调至所需压力即可。
- 3、调压阀一般故障较少，常见的故障为膜片，密封圈等橡胶元件的损坏，建议用户定货时备一些备件，以便更换。
- 4、调压阀在停止使用时，应关闭阀前截止阀。

Pressure regulating valve of the debugging and the maintenance

- 1、Before commissioning should check whether the correct installation
- 2、Debugging, turn off bypass valve, then open valve and valve respectively before the cut-off valve. Turn the pressure regulating valve the regulation on the hand wheel, and observation after valve pressure gauge, until the adjustment to the necessary pressure can.
- 3、Pressure regulating valve general fault less, common fault for diaphragm, seals and other rubber element damage, it is recommended that the user when order for some spare parts, so as to change.
- 4、Pressure regulating valve in the stop using, should close valve former cut-off valve.

型号编制说明 Model establishment that

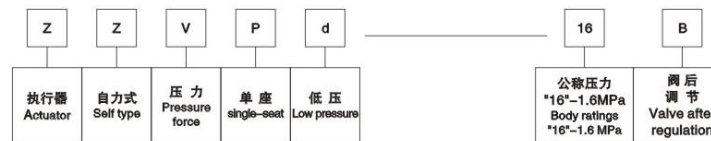

订货须知

- 1、调压阀的型号、名称
- 2、公称直径、压力
- 3、阀前及阀后压力
- 4、阀体的材质
- 5、有何特殊要求

Order instructions

- 1、pressure regulating valve model, name
- 2、nominal diameter, pressure
- 3、valve before and after valve pressure
- 4、the valve body material
- 5、have any special requirements

用途

ZZVP-16B型自力式微压调节阀(以下简称微压阀)是利用被调介质自身的压力变化来驱动执行器而达到自动稳定阀后压力的目的,可广泛应用于各类低腐蚀常温气体的低压调节场合。

产品符合GB/T4213-1992。

Use

ZZVP-16B type self type low voltage regulator (hereinafter referred to as the "low pressure valve") is the use of modulated medium their stress change to drive actuator and achieve automatic stabilization valve after the purpose of pressure, and can be widely Applied to all kinds of low corrosion cold gas low voltage control occasions.

Products comply with GB/T4213-1992.

产品特点

1、阀芯为平衡式、不平衡力小,反应灵敏,精度高。2、外形紧凑、美观、以便安装。3、调校及维修方便。

Product features

1, valve core is balanced and unbalanced force is small, the sensitive reaction and high precision. 2, compact appearance, beautiful, in order to install. 3, adjustment and convenient maintenance.

主要技术参数 Main technical parameters

公称压力(MPa) Nominal pressure	1.6MPa
进口压力 Inlet pressure	≤0.6MPa
阀后压力调节范围 After the valve pressure regulating range	2.5~20KPa(250~2000mmH ₂ O)
调节精度 Control accuracy	8%
使用温度 Using temperature	-10~+55℃
法兰标准 Flange standards	JB79-59

结构及动作原理

调压阀的主要结构见图一

当介质经阀体、阀芯及阀座减压后流出,阀后的压力经反馈管反馈至膜片下方,产生向上推力,与平衡弹簧的设定力平衡。阀芯就稳定在与阀后压力对应的开度上。当阀后的压力变化时,经反馈,阀芯的开度也相应变化,使阀后的压力始终保持恒定的输出。同理,当平衡弹簧的设定力改变时,阀后的压力也会相应的变化。所以拧动调节手轮就可以方便地调出所需要的阀后压力。

The structure and operating principle

Pressure regulating valve of the main structure see chart -

When the medium body, valve core and valve seat after decompression outflow, valve pressure after the feedback tube feedback to diaphragm below, produce the upward thrust, and balance spring setting force balance. Valve core is stable in After the valve and pressure corresponding to the opening. When the valve after the pressure change, the feedback, valve core opening also corresponding change, make the valve after the pressure always keep constant output. Similarly, when the balance of the spring Setting force changes, the valve after the pressure will also corresponding change. So budge regulation handwheel can easily v needed after valve pressure.

调压阀的系列参数及外形尺寸 Pressure regulating valve series of parameters and external dimensions

公称通径(mm) Nominal diameter	25	32	40	50	65	80	100
流量系数KV Flow coefficient	8	12	20	32	50	80	120
L	185	200	222	254	276	298	352
H ₁	90	100	110	125	150	160	165
H	460	480	690	720	960	980	1000
φ A	290	290	364	364	454	454	454

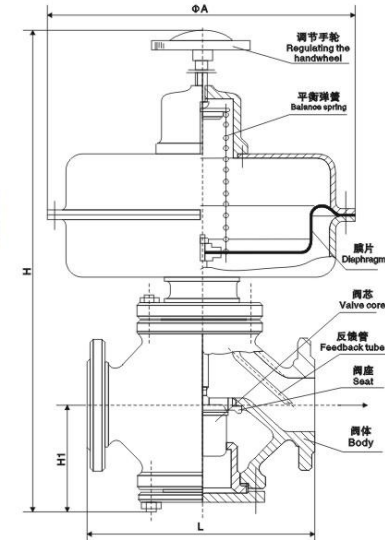

调压阀主要零件材质 Pressure regulating valve main parts material

零件名称 Part name	材料 Material
阀体 Valve body	HT200; ZG230-450; ZG1Cr18Ni9Ti
阀芯 Valve core	ZG1Cr18Ni9Ti
阀座 Seat	1Cr18Ni9
密封圈 Seal	橡胶1-2 Rubber 1-2
膜片 Diaphragm	丁腈橡胶夹增强涤纶织物 Nitrile rubber clamp enhance QIGuan fabric
弹簧 Spring	60Si2MnA
导向套 Guide sleeve	LY12

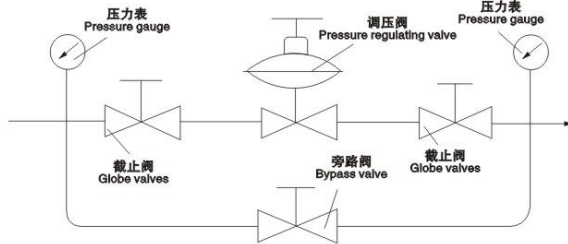

调节阀的安装

- 1、调节阀在安装以前，必须对管道进行彻底冲洗，不得有杂物。条件允许，建议在阀前加装过滤器。
- 2、调节阀一般应正立安装在管道上，并且介质的流向应与阀体上的箭头一致。
- 3、调节阀一般应配置旁路，以便应急和维修。

Pressure regulating valve installation

- 1、pressure regulating valve in installation ago, must to conduit rinse thoroughly, can not have sundry. The condition allows, the proposal in the valve before adding filter.
- 2、pressure regulating valve should be generally are made installed on the pipeline, and the flow of medium should be consistent with the arrow on the valve body.
- 3、pressure regulating valve should be generally configuration bypass, so that emergency and maintenance.

调节阀的调试及保养

- 1、调试前应检查安装是否正确
- 2、调试时，先关闭旁路阀，然后分别打开阀后及阀前的截止阀。旋动调节阀上的调节手轮，并观察阀后压力表，直至调至所需压力即可。
- 3、调节阀一般故障较少，常见的故障为膜片，密封圈等橡胶元件的损坏，建议用户定货时备一些备件，以便更换。
- 4、调节阀在停止使用时，应关闭阀前截止阀。

Pressure regulating valve of the debugging and the maintenance

- 1、Before commissioning should check whether the correct installation
- 2、Debugging, turn off bypass valve, then open valve and valve respectively before the cut-off valve. Turn the pressure regulating valve the regulation on the hand wheel, and observation after valve pressure gauge, until the adjustment to the necessary pressure can.
- 3、Pressure regulating valve general fault less, common fault for diaphragm, seals and other rubber element damage, it is recommended that the user when order for some spare parts, so as to change.
- 4、Pressure regulating valve in the stop using, should close valve former cut-off valve.

型号编制说明 Model establishment that

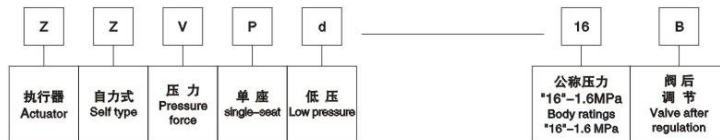

订货须知

- 1、调节阀的型号、名称
- 2、公称直径、压力
- 3、阀前及阀后压力
- 4、阀体的材质
- 5、有何特殊要求

Order instructions

- 1、pressure regulating valve model, name
- 2、nominal diameter, pressure
- 3、valve before and after valve pressure
- 4、the valve body material
- 5、have any special requirements

特点

无需外加能源，能在无电、无气的场合工作，即方便，又节能，降低成本；氮封装置供氮、泄氮压力设定方便。可在连接生产的条件下进行；压力检测膜片有效面积大，设定弹簧刚度小，动作灵敏，装置工作平稳；采用无填料设计，阀杆所受摩擦小，反应迅速，控制精度高；供氮装置采用指挥器操作，减压比可达100:1，减压效果好，控制精度高；为确保储罐的安全，需在罐顶设置呼吸阀；呼吸阀仅起安全作用，避免了常规氮封装置中启闭频繁易损坏的缺陷。

Characteristics

No applied energy, can in no power, no gas situation work, namely convenient, and save energy, reduce the cost; Nitrogen seal for nitrogen, drain nitrogen pressure set is convenient. Can be in connection production under the condition of: Pressure testing diaphragm effective area is big, setting spring stiffness is small, the action is sensitive, the device work smoothly; Using packless design, valve rod by friction small, rapid response, high control precision. For nitrogen device adopts command unit operation, reduced pressure ratio can reach 100:1, decompression effect is good, high control precision. In order to ensure the safety of the tank, need to set up in the roof breathing valve; Breathing valve only up security function, avoid the conventional nitrogen seal device open-close frequent destructible defect.

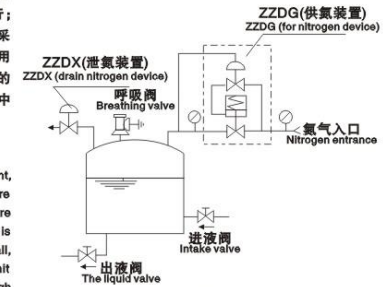

图三 系统图
Graph 3 system diagram

特点和用途

ZZDQ氮封装置是本厂自主开发、研制的一套自力式微压力控制系统，主要用于保持窗口顶部保护气（一般为氮气）的压力恒定，以避免窗口内物料与空气直接接触，防止物料挥发、被氧化，以及窗口的安全。特别适用于各类大型储罐的气封保护系统。该产品具有节能、动作灵敏、运行可靠、操作与维修方便等特点。广泛应用于石油、化工等行业。

产品符合GB/T4213-1992。

Characteristics and USES

ZZDQ nitrogen seal is our independent development, developed a set of self decline pressure control system, mainly used to keep on top of a window to protect gas (usually nitrogen) pressure constant, in order to avoid window in direct contact with the material and air, prevent material volatilize, oxidation, and the safety of the window. Especially suitable for all kinds of large storage tank of gas seal protection system. This product has the energy saving, action quick, luck Line reliable, operation and easy maintenance, etc. Widely used in petroleum, chemical and other industries.

Products comply with GB/T4213-1992.

结构工作原理

氮封装置由供氮装置(见图一)和泄氮装置(见图二)两部分组成。供氮装置由指挥器和主阀两部分组成；泄氮装置由内反馈的压开型微压调节阀组成。氮气压力一般设为100mmH₂O，通过氮封装置精确控制。

当储罐进液阀开启，向罐内添加物料时，液面上升，气相部分容积减小，压力升高，当罐内压力升至高于泄氮装置压力设定值时，泄氮装置打开，向外界释放氮气，使罐内压力下降，降至泄氮装置压力设定点时，泄氮装置自动关闭。

当储罐出液阀开启，用户放料时，液面下降，气相部分容积增大，罐内压力降低，供氮装置开启，向储罐注入氮气，使罐内压力上升，当罐内压力上升至供氮装置自动关闭。

Structure working principle

Nitrogen seal by for nitrogen device (see chart 1) and release nitrogen device (see chart 2) of two parts. For nitrogen device from the command device and the main valve of two parts; Drain nitrogen device by inside feedback pressure open type micro pressure regulator Composition. Nitrogen pressure generally set for 100mmH₂O, through the nitrogen seal precise control.

When tank intake valve open, add to the tank material, liquid level rise, gas phase partial volume decreases, and pressure increase, when tank pressure to above drain nitrogen plant pressure setting, drain nitrogen device Open to the outside world release nitrogen, make the tank pressure drop, drop to drain nitrogen plant pressure set point, drain nitrogen plant shut down automatically.

When tank out of the liquid valve opening, the user emptying, drawdown, gas phase partial volume increases, the tank pressure is reduced, for nitrogen plant open, to tank injection nitrogen, make the tank pressure rise, when tank Internal pressure rise to for nitrogen plant shut down automatically.

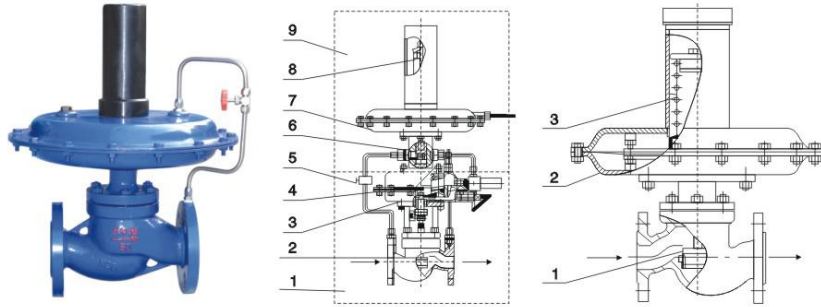

1、主阀 2、主阀阀芯 3、主阀执行机构 4、节流阀 5、减压阀
6、指挥器阀芯 7、检测机构 8、预设弹簧 9、指挥器
1、the main valve 2、the main valve valve core 3、the main valve actuator
4、throttle valve 5、pressure reducing valve 6、command device valve core
7、detect organization 8、the preset spring 9、command device

图四 供氮装置外形尺寸图
Graph 4 for nitrogen plant shape size drawing

1、主阀 2、检测机构 3、弹簧
1、the main valve 2、detect organization 3、spring

图四 泄氮装置外形尺寸图
Graph 4 drain nitrogen plant shape size drawing

供氮装置工作原理

供氮装置结构(见图四), 将设在罐顶的取压点的介质经导压管引入检测机构(7)、介质在检测元件上产生一个作用力与弹簧(8)、预紧力相平衡。当罐内压力降低至低于供氮装置压力设定点时, 平衡破坏, 使指挥器阀芯(6)打开, 使阀前气体经减压阀(5)、节流阀(4)、进入主阀执行机构(3)上、下膜室, 打开主阀阀芯(2)、向罐内充注氮气; 当罐内压力升至供氮装置压力设定点。由于预设弹簧力, 关闭指挥器阀芯(6)、由于主阀执行机构中弹簧作用。关闭主阀, 停止供氮。

For nitrogen device working principle

For nitrogen device structure (see chart 4), will be located in the roof take pressure point medium by connecting pipe introduced testing institutions (7), medium in detecting element produce a force and spring (8), prestressing force phase balance. When the tank pressure drops to below for nitrogen plant pressure set point, balance, destroying command device valve core (6) open, make the valve before gas by pressure reducing valve (5), throttle valve (4), into the main valve holding line organization (3) upper and lower membrane room, open the main valve valve core (2), to the tank filling nitrogen; When the tank pressure to for helium device pressure set point. As the preset spring force, close command device valve core (6), The main valve actuator spring action. Shut off the main valve, stop for nitrogen.

泄氮装置工作原理

泄氮装置结构(见图五), 该装置采用内反馈结构, 介质直接经阀盖进入检测机构(2), 介质在检测元件上产生一个作用力与预设弹簧(3)预紧力相平衡。当罐内压力升高至高于泄氮装置压力设定点时, 平衡被破坏, 使阀芯(1)上移, 打开阀门, 向外界泄放氮气; 当罐内压力降至泄氮装置压力设定点, 由于预设弹簧力作用, 关闭阀门。

Drain nitrogen device working principle

Drain nitrogen device structure (see chart 5), this device adopts internal feedback structure, medium directly the valve cover into examination organization (2), medium in detecting element produce a force and preset spring (3) preliminary Tight force phase equilibrium. When the tank pressure increases to above drain nitrogen plant pressure set point, balance is destroyed, make the valve core (1) up, open the valve, to external discharge nitrogen; When the tank pressure drop to drain Nitrogen plant pressure set point, as the preset spring force, close the valve.

说明

- 一般供氮气压在 $3 \times 10^5 - 10 \times 10^6 \text{Pa}$ 之间;
- 罐顶呼吸阀仅起安全作用, 是在主阀失灵, 导致罐内压力过高或过低时, 起到安全作用, 在正常情况下不工作;
- 泄氮阀安装在罐顶。口径一般一致;
- 一般泄氮阀的压力设定点略大于供氮阀的压力设定点, 以免供、泄氮装置频繁工作, 浪费氮气、影响设备使用寿命。
- 若用户工况与选型手册有异, 望来电与本公司技术开发部联系, 协商解决

Explain

- General for nitrogen pressure in $3 \times 10^5 - 10 \times 10^6 \text{pa}$ between;
- Fox roof breathing valve only up security function, is in the main valve failure, leading to tank pressure too high or too low, a security role, in normal circumstances not working;
- Release nitrogen valve installed on the roof. Caliber general agreement;
- General release nitrogen valve pressure set point is slightly bigger than for nitrogen valve pressure set point, in order to avoid supply and drain nitrogen plant frequent work, waste nitrogen, affect the service life of apparatus.
- If the user had condition and selection manual have different, hope calls and our technology development department contact, talk things over solve

主要技术参数及性能指标 The main technical parameters and performance index

1、供氮装置主要技术参数及性能指标 For nitrogen plant main technical parameters and performance index

公称直径(mm) Nominal diameter	25										32	40	50	65	80	100
阀座直径(mm) Seat diameter	5	6	7	8	10	12	15	20	25	32	40	50	65	80	100	
额定流量系数(Kv) Rated flow coefficient	0.2	0.32	0.5	0.8	1.8	2.8	4.4	6.9	11	20	30	48	75	120	190	
额定行程L(mm) Rated stroke	8										10	14	20	25		
流量特性 Flow characteristic	快开 Quick opening															
压力调节范围(KPa) Pressure regulating range	0.4-5.5、5-10、9-14、13-19、18-24、22-28、27-33、31-38、36-44、42-51、49-58、56-66															
公称压力(MPa) Nominal pressure	1.6、2.5、4.0															
被调介质温度℃ Modulated medium temperature	≤80															
调节精度(%) Control accuracy	±5%															
允许泄漏等级 Allow leakage level	标准级: IV级(GB/T4213-92) 严密型: IV级(GB/T4213-92) Standard: level IV (GB/T4213-92) Close type: level IV (GB/T4213-92)															

2、泄氮装置主要技术参数及性能指标 Drain nitrogen plant main technical parameters and performance index

公称直径(mm) Nominal diameter	20	25	32	40	50	65	80	100	
额定流量系数(Kv) Rated flow coefficient	6.9	11	30	30	48	75	80	190	
额定行程L(mm) Rated stroke	8		10			14		20	25
流量特性 Flow characteristic	快开 Quick opening								
压力调节范围(KPa) Pressure regulating range	0.1								
公称压力(MPa) Nominal pressure	0.1								
被调介质温度℃ Modulated medium temperature	≤80								
调节精度(%) Control accuracy	±5%								
允许泄漏等级 Allow leakage level	标准级: IV级(GB/T4213-92) 严密型: IV级(GB/T4213-92) Standard: I/level(GB/T4213-92) Close type: I/level(GB/T4213-92)								

主要零部件材料

阀体: ZG230-450、ZG1Cr18Ni9Ti 阀内件: 1Cr18Ni9Ti

膜盖: A3、1Cr18Ni9Ti 膜片: 夹增强涤纶织物丁腈橡胶、氟橡胶

弹簧: 60Si2Mn、1Cr18Ni9Ti

*根据用户要求, 阀体、阀内件、膜盖可采用其它牌号材质。

* According to user requirements, the valve body, valve internals, membrane cover can use other brand material.

The main components material

Body: ZG230-450, ZG1Cr18Ni9Ti; 1Cr18Ni9Ti

Membrane cover: A3, 1Cr18Ni9Ti; diaphragm: Clamp enhance polyester fabric acrylonitrile butadiene rubber, Fluorine rubber

Spring: 60Si2Mn, 1Cr18Ni9Ti

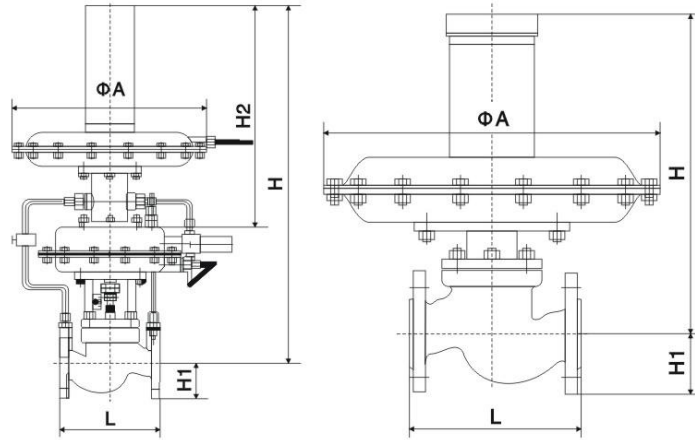

图四 供氮装置外形尺寸图
Graph 4 for nitrogen plant shape size drawing

图四 泄氮装置外形尺寸图
Graph 4 drain nitrogen plant shape size drawing

主要零部件材料 The main components material

1、供氮装置外形尺寸及重量 For nitrogen plant shape size and weight

公称通径(mm) Nominal diameter	25	32	40	50	65	80	100
L	180	180	200	230	290	310	350
A	308	308	308	308	394	394	394
H ₂	415	415	415	415	415	415	415
H ₁	60	75	80	85	95	105	120
H	720	730	730	750	790	840	890
重量(kg) Weight	32	35	40	50	90	115	280

2、泄氮装置外形尺寸及重量 Drain nitrogen plant shape size and weight

公称通径(mm) Nominal diameter	25	32	40	50	65	80	100
L	160	180	200	230	290	310	350
A	308	308	308	308	394	394	394
H ₁	60	75	80	85	95	105	120
H	720	400	480	430	550	560	570
重量(kg) Weight	32	13	15	17	20	28	38

连接尺寸及标准

连接方式: 法兰、螺纹

法兰端面距: GB12221-89

法兰标准: GB/T 9113-2000

法兰面型式: RF

执行机构气信号接口: M16×15

注: 以上数据可根据用户需要加工制造。

Connection dimension and standard

Connection: flange, thread

Flange face distance: GB12221-89

Flange standards: GB/T 9113-2000

Flange face type: RF

Actuator air signal interface: M16×15

Note: the above data can be based on user needs processing manufacturing.

ZDQ氮封装置型号编制说明 ZDQ nitrogen seal model establishment description

公称通径(mm) Nominal diameter	阀座直径(dg)(mm) Seat diameter	结构 Structure 供氮装置 (For nitrogen device)	公称压力(MPa) Nominal pressure	连接法兰标准 Connecting flange standards	压力调节范围(KPa) Pressure regulating range	压力设定点(KPa) Pressure set point	阀体材料 Body material
025	25	003	3	S	0.4~5.5、5~10		C ZG230-450
032	32	004	4	U	9-14、13-19		P ZG1Cr18Ni9Ti
040	40	005	5		18-24、22-28		U 用户自订
050	50	006	6		27-33、31-38		
065	65	007	7		36-44、42-51		
080	80	008	8		49-58、56-68		
010	10	012	12				
015	15	015	15				
020	20	020	20				
025	25	025	25				
032	32	032	32				
040	40	040	40				
050	50	050	50				
065	65	065	65				
080	80	080	80				
100	100	100	100				

ZDG氮封装置型号编制说明 ZDG nitrogen seal model establishment description

公称通径(mm) Nominal diameter	结构 Structure 泄氮装置 (Drain nitrogen device)	公称压力(MPa) Nominal pressure	连接法兰标准 Connecting flange standards	压力调节范围(KPa) Pressure regulating range	压力设定点(KPa) Pressure set point	阀体材料 Body material
025	25	1.0	1.0	S	0.4~5.5、5~10	C ZG230-450
032	32			U	9-14、13-19	P ZG1Cr18Ni9Ti
040	40				18-24、22-28	U 用户自订
050	50				27-33、31-38	
065	65				36-44、42-51	
080	80				49-58、56-66	
100	100					

例:

型号为: 025×015ZZDQ16S0.5-5.5-P表示公称通径(DN)为25mm, 阀座直径(dg)为15mm, 公称压力(PN)为1.6MPa, 连接法兰按制造厂标准, 压力调节范围为0.5-5KPa, 供氮压力为1KPa, 阀体材质为ZG1Cr18Ni9Ti的一套供氮装置;

型号为: 040ZZDX1.0S0.5-5.5-1.5P表示公称通径(DN)为40mm, 公称压力(PN)为0.1MPa, 连接法兰按制造厂标准, 压力调节范围为0.5-5KPa, 泄氮压力为1.5KPa, 阀体材质为ZG1Cr18Ni9Ti的一套泄氮装置。

Example:

Model for: 025×015ZZDQ16S0.5-5.5-PSaid nominal diameter (DN)for25mm, Seat diameter(dg)for15mm, Nominal pressure (PN)for1.6MPa, Connecting flange according to manufacturer standard, pressure regulator range0.5-5KPa, For nitrogen pressure for1KPa, Body material forZG1Cr18Ni9TiA set of device for nitrogen;

Model for: 040ZZDX1.0S0.5-5.5-1.5P said nominal diameter(DN)for40mm, Nominal pressure(PN)for0.1MPa, Connecting flange according to manufacturer standard, pressure regulator range 0.5-5KPa, Drain nitrogen pressure for 1.5KPa, Body material forZG1Cr18Ni9TiA set of drain nitrogen device.

订货须知

- 1、装置名称、型号
- 2、供氮、泄氮装置公称通径DN(mm)
- 3、供氮、泄氮装置公称压力PN(MPa)
- 4、供氮、泄氮装置额定流量系数Kv
- 5、供氮、泄氮装置固有流量特性
- 6、供氮、泄氮装置压力设定点
- 7、介质名称
- 8、工作压力及调节范围
- 9、阀体、阀内件及填料材质
- 10、其他特殊要求

Order instructions

- 1、unit name, model
- 2、for nitrogen, drain nitrogen unit nominal diameter DN (mm)
- 3、for nitrogen, drain nitrogen unit nominal pressure PN (MPa)
- 4、for nitrogen, drain nitrogen plant rated flow coefficient Kv
- 5、for nitrogen, drain nitrogen plant the intrinsic flow feature
- 6、for nitrogen, drain nitrogen plant pressure set point
- 7、medium name
- 8、working pressure and the adjusting range
- 9、the valve body, valve internals and packing material
- 10、and other special requirements

特点和用途

ZZYP-250B型自力式减压阀是利用被调介质自身的压力为动力来推动执行器动作, 改变流过阀芯的流量, 从而自动稳定阀后压力的节能型调节阀。一般应用在各类高压介质的初级降压系统中。

- 特点: (1)结构紧凑, 安装方便;
- (2)无须外界动力, 可节约投资;
- (3)阀芯及阀座采用硬化工艺及特殊结构, 可在较大压差下连续工作。

Characteristics and USES

ZZYP-250B type self type pressure reducing valve is the use of modulated medium own pressure into motive force to push actuator action, change the flow through valve core flow, thereby automatic stabilization valve pressure after the festival Can type valve. Normally used in all kinds of high pressure medium primary decompression system.

- Characteristics: (1) The structure is compact, easy installation,
- (2) Without external power, can save investment;
- (3) The valve core and valve seat hardened technology and special structure, can be in large pressure differentials work continuously.

结构和动作原理

调节阀的主要结构:

- 调节阀主要由阀组件和执行机构两大组件组成。
- 执行机构为压力敏感机构, 它接受来自阀后压力反馈信号, 并将其转换成推杆的位移。
- 阀组件为流量调节机构, 通过阀芯的位移来改变流入阀后的流量, 维持阀后的压力。

Structure and movement principle

Pressure regulating valve of the main structure:

- Pressure regulating valve is mainly composed of valve components and actuator two component.
- Actuator for pressure sensitive mechanism, it receives from the valve after pressure feedback signal, and converts it push rod displacement.
- Valve components for flow control mechanism, through the valve core displacement to change into the valve after the flow, maintain valve after the pressure.

调节阀的动作原理:

当介质经阀芯、阀座流向阀后, 阀后的压力经反馈管输入执行机构, 使推杆产生向下的推力并向下产生位移。从而推动阀芯动作改变流量。当推杆的推力与平衡弹簧的设定力平衡时, 阀芯就稳定在与阀后压力对应的开度上。当阀前压力或阀后负载变化时, 经反馈, 推杆也相应地移动, 使阀后的压力一直保持稳定的输出。

同时, 当改变阀后压力时, 只要改变平衡弹簧的设定力, 就会改变阀后的输出压力。所以, 只要旋转压力调节螺母, 就可以方便地调出所需要的压力。

Pressure regulating valve action principle:

When the medium the valve core and valve seat flow valve, valve pressure after the feedback tube input actuator, make the push rod produce downward thrust and downward produce displacement. Thus promote the valve core action change flow Quantity. When push rod thrust and balance spring setting force balance, the valve core and valve is stable in the pressure corresponding to the opening. When the front pressure or valve after load changes, the feedback, push rod and phase should be moving, and after the valve pressure remained stable output.

At the same time, when change after valve pressure, as long as the change of the balance spring set force, it will change the valve after the output pressure. So, as long as the rotating pressure adjusting nut, it can be easily decrultment need pressure.

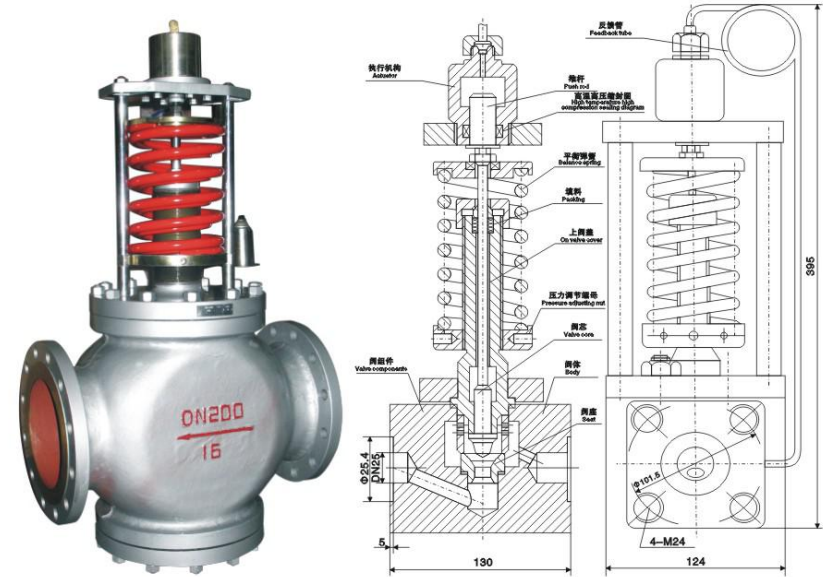

图一 ZZYP-250B 自力式调节阀外形结构图
Graph one ZZYP-250B self type valve shape structure

主要技术参数 Main technical parameters

公称通径(mm) Nominal diameter	25
公称压力(MPa) Nominal pressure	25
额定流量系数Kv Rated flow coefficient	1.5
入口压力MPa Inlet pressure	≤17
出口压力调节范围MPa Outlet pressure regulating range	5~10(出厂时设定压力为6.5~7.5) 5~10(factory ShiDiao constant pressure is 6.5~7.5)
使用温度℃ Using temperature	介质温度-10~+350;环境温度-20~+80 Medium temperature -10~+350; The environment temperature -20~+80
压力调节精度 Pressure regulation precision	±15%
阀芯关闭时泄漏量 Valve core closed leakage set	0.01% × 阀额定容量 0.01% × valve rated capacity
连接型式 Connection type	法兰连接、法兰标准: GB9113.15-88 Flange connection, flange standards: GB9113.15-88

ZZYP-250B型自力式减压阀 ZZYP-250B type self type pressure reducing valve

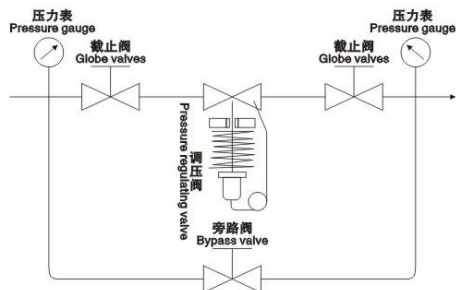

Pressure regulating valve installation

调压阀的安装

- 1、调压阀在安装前应彻底冲洗管道，不得残留任何杂质。
1. Pressure regulating valve should be installed in before thoroughly flush piping, and may not remain any impurity.
- 2、调压阀应倒立安装在管道上，并保持良好的通风。
2. Pressure regulating valve should be inverted installed in the line, and should keep good ventilation.
- 3、在安装时介质的流向应与阀体上的箭头一致。
3. When installing the medium flow with the arrow on the valve body shall be consistent.
- 4、调压阀应该设置旁路，以便应急及维修。
4. Pressure regulating valve should be set to bypass, so that emergency and maintenance.

调压阀的调试及使用

- 1、调试前应仔细检查各部安装是否正确；
1. Before debugging, you should carefully check each part of the installation is correct;
- 2、调试时，应先关闭旁路阀，然后打开阀后截止阀，最后缓慢开启阀前截止阀，调压阀即进入工作状态。
2. When debugging, you should first close the bypass valve, then open the valve after cut-off valve, and finally slowly open valve former cut-off valve, pressure regulating valve is in working condition.
- 3、如发现压力与工艺需要不符，可旋转压力调节螺母，调节调压阀的输出压力(压缩弹簧为压力升高，放松弹簧为压力降低)。直至调出所需的压力。
3. Such as the discovery of pressure and process need not, can rotate pressure adjusting nut, regulate the pressure regulating valve output pressure (compression spring for pressure, relax spring for pressure drops). Until decruitment required Pressure.
- 4、当调压阀停止使用时，必须关闭阀前的截止阀。
4. When the pressure regulating valve to stop the use, must be closed valve before the cut-off valve.

Pressure regulating valve debugging and use

- 1、Debugging carefully before check each installation is correct;
- 2、Debugging, you should turn off bypass valve, and then open the valve after cut-off valve, and finally slowly open valve former cut-off valve, pressure regulating valve is in working condition.
- 3、Such as the discovery of pressure and process need not, can rotate pressure adjusting nut, regulate the pressure regulating valve output pressure (compression spring for pressure, relax spring for pressure drops). Until decruitment required Pressure.
- 4、When the pressure regulating valve to stop the use, must be closed valve before the cut-off valve.

调压阀的维护及保养

- 1、调压阀在正常使用中，一般故障较少，但应定期检查其各密封处是否有泄漏。
1. Pressure regulating valve in normal use, the general fault less, but shall regularly check the seal the leaks.
- 2、调压阀在长期使用后应进行检修(一般一年为一周期)，所有密封件必须全部更换，阀芯及阀座如有较严重的冲蚀现象，也应更换。
2. pressure regulating valve in use for a long time after repair should be (usually one year for a cycle), all the seals must be all replacement, valve core and valve seat if there is a more serious erosion phenomenon, should also change.

Pressure regulating valve maintenance and maintenance

- 1、pressure regulating valve in normal use, the general fault less, but shall regularly check the seal the leaks.
- 2、pressure regulating valve in use for a long time after repair should be (usually one year for a cycle), all the seals must be all replacement, valve core and valve seat if there is a more serious erosion phenomenon, should also change.

型号编制说明 Model establishment that

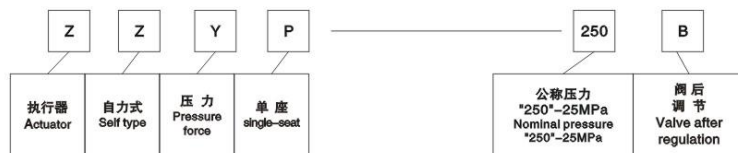

ZWT自力式温度调节阀 ZWT self type temperature control valve

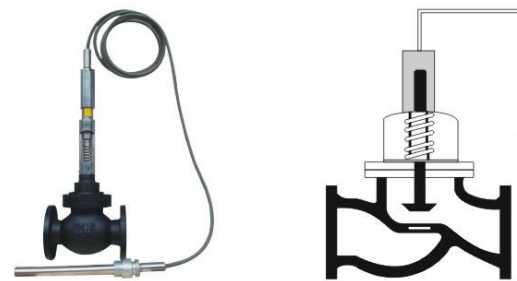

加热用温度调节阀 原理图
Heating temperature control valve principle diagram

适用场合

自力式温度调节阀无需外界能源便可自动进行温度控制，广泛应用于生活热水供应，供暖、空调等热交换场合及化工、纺织、印染、制药等生产过程。适用介质可为蒸汽、高温水、热油、冷却水、冷冻水等。

Applicable occasions

Self type temperature control valve without external energy can be automatic temperature control, which are widely used in domestic hot water supply, heating, air conditioning and heat exchange occasion and chemical industry, textile, printing and dyeing, system Medicine and other production process, applicable medium for steam, high temperature water, hot oil, cooling water, chilled water, etc.

工作原理

我公司生产的自力式温度调节阀按用途分为以下几种：加热用温控阀；冷却用温控阀；合流温度调节阀；分流温度调节阀。不同用途的自力式温度调节阀的工作原理大体相同，都是利用感温液体受热膨胀、遇冷收缩及液体不可压缩的原理进行调节。下面以加热用两通阀为例，结合工作原理示意图说明其工作过程：将温度传感器插入需要控制温度的介质中，当介质温度升高时，感温液体膨胀，作用力克服了弹簧阻力，推动阀瓣向下运动，阀门趋于关闭，从而减少热媒介质的流量；反之，当介质温度低于设定温度时，感温液体收缩，复位弹簧推动阀瓣开启，增加热媒介质流量，使被控介质温度趋于升高。循环往复，从而使被控介质的温度值始终保持在设定温度值允许的范围内。

Working principle

Our company produces the self type temperature control valve in use is divided into the following several kinds: heating temperature control valve; Cooling with temperature control valve; Junction temperature control valve, Shunt temperature control valve. Different USES Self type temperature control valve work principle is approximately the same as that, all is the use temperature liquid expands when it is heated and contract when they freeze and liquid incompressible principle of regulation. Below to heating two-way valve as an example, Connecting with the working principle diagram shows its working process: the temperature sensor insert need to control the temperature of the medium, when the medium temperature rises, the thermal expansion of liquids, force to overcome the spring resistance Force, promote the disc downward movement, the valve tends to close, so as to reduce heat media qualitative flow; Conversely, when the medium temperature below the setting temperature, temperature liquid contraction, reset spring push disc Open, Increase the heat medium mass flow, was accused of medium temperature tends to rise. Cycle reciprocating, so that was accused of medium temperature remains in the allowing range of temperature setting.

产品特点

- 无需电或压缩空气等外界能源，安全可靠；
- 感温液体膨胀均匀，比例式调节控制；
- 可控介质种类多，可应用于多种控制场合；
- 控制精度高，工作稳定，有效节约能源；
- 平衡式阀体设计，使阀能在更大压差下工作；
- 线性或等百分比流量特性；
- 温度设定操作简单，方便用户调节；
- 设备体积小，重量轻，安装非常方便。

Product features

- Had no electricity or compressed air external energy, safe and reliable;
- Temperature liquid expansion uniformly, proportion type adjustment control;
- Controlled medium types, can be applied to a variety of control occasions;
- High control precision, work stability, effective energy saving;
- Balanced body design, make valve can be in more work under pressure difference;
- Linear or equal percentage flow characteristic;
- Temperature setting simple operation, convenient user regulation;
- Equipment small volume, light weight, installation is very convenient.

温控范围 Temperature control range

用于生活热水供应 For living hot water supply	30-80℃
用于采暖、中央空调供暖 Used for heating, central air-conditioning heating	40-90℃
用于除氧器等生产工艺过程 Used for deaerator and other production process	80-110℃
用于其它特殊用途 Used for special purposes	120-180℃

参数性能 Parameter performance

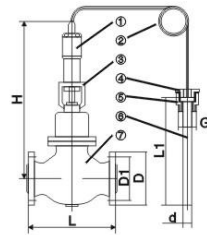

外形尺寸图 Appearance size drawing

- | | |
|-----------|-------------------------------------|
| ① 调温旋钮 | ① Thermal control knob |
| ② 导管 | ② The catheter |
| ③ 支架 | ③ Support |
| ④ 温度传感器联塞 | ④ The temperature sensor group plug |
| ⑤ 温度传感器联母 | ⑤ Temperature sensor group mother |
| ⑥ 温度传感器 | ⑥ Temperature sensor |
| ⑦ 平衡式阀体 | ⑦ Balanced body |

DM (mm)	Kv值 (m ³ /h) Value	D (mm)	D1 (mm)	螺栓孔 (n-Φ) Bolt hole	L (mm)	d (mm)	L1 (mm)	H (mm)	G (in)	导管长 (m) Catheter long
32	11	135	100	4-Φ18	180	25	430	380	1-1/4"	3
40	15	145	110	4-Φ18	200	25	430	410	1-1/4"	3
50	19	160	125	4-Φ18	230	25	430	450	1-1/4"	3
65	31	180	145	4-Φ18	290	25	430	490	1-1/4"	3
80	52	195	160	8-Φ18	310	25	430	530	1-1/4"	3
100	78	215	180	8-Φ18	350	25	430	560	1-1/4"	3
125	122	245	210	8-Φ18	395	25	550	600	1-1/4"	4
150	190	280	240	8-Φ23	470	25	550	640	1-1/4"	4
200	300	335	295	12-Φ23	600	25	550	690	1-1/4"	4
250	450	400	355	12-Φ23	630	25	550	720	1-1/4"	4

- 注: 1. D、D1、n-Φ为PN1.6MPa法兰接口尺寸。
 2. 如用户需要PN2.5MPa产或口径为DN15、DN20、DN25、DN300的产品, 请向我公司查询尺寸。
 3. 阀体材质: 普通铸铁、球墨铸铁、铸钢。
- Note: 1. D、D1、n-Φ for PN1.6MPa Flange connection size.
 2. If you need PN2.5MPa Production or diameter for DN15、DN20、DN25、DN300 products, please contact our company inquires the size.
 3. Body material: ordinary cast iron, nodular cast iron, cast steel.

典型系统

说明: 温度调节阀根据换热器二次侧出口温度自动调节一次侧阀门的开启, 实现二次侧出水温度的恒定控制。

Typical system

Description: temperature control valve according to heat exchanger secondary side exit temperature automatic control a side valve opening, realize thesecondary side water temperature constant control.

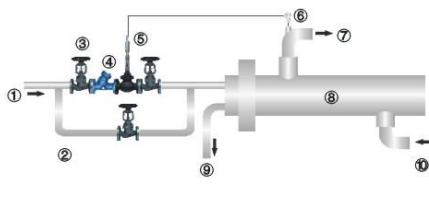

- | | |
|------------|-------------------------------------|
| ① 一次侧介质进口 | ① the primary side medium import |
| ② 旁通管路 | ② the by-pass line |
| ③ 截止阀 | ③ cut-off valve |
| ④ 过滤阀 | ④ filtering valve |
| ⑤ 加热用温度调节阀 | ⑤ heating temperature control valve |
| ⑥ 温度传感器 | ⑥ temperature sensor |
| ⑦ 二次侧介质出口 | ⑦ secondary side medium export |
| ⑧ 换热设备 | ⑧ and heat exchange equipment |
| ⑨ 一次侧介质出口 | ⑨ a side medium export |
| ⑩ 二次侧介质入口 | ⑩ secondary side medium inlet |

注: 具体安装使用方法请参阅产品包装内部的安装使用说明书。本阀不能作截止阀使用, 系统停止时应关闭本阀前端截止阀。
 Note: the installation method of use, please refer to product packaging internal installation and operation instruction. This valve cannot be cut-off valve use, the system stops should close the valve front cut-off valve.

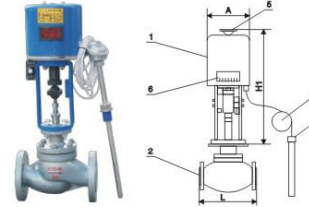

外形示意图

- 智能型执行器
- 主阀体
- 传感器
- 毛细管
- 手动机构

Appearance schematic diagram

- intelligent actuators
- main body
- sensor
- capillary
- the manual institutions

备注: 常说的加热型、冷却型。在此阀中只要更换阀芯结构即可以实现。
 Note: Often say heating type, cooling type. In this valve as long as replacement valve core structure which can realize.

用途与特点

自力式电控温度调节阀(适用于较大口径及导热油控制), 该阀最大的特点只需普通220V电源, 利用被调介质自身能量, 直接对蒸汽、热水、热油与气体等介质的温度实行自动调节和控制, 亦可在防止对过热或热交换场合, 该阀结构简单, 操作方便, 选用调温范围广、响应时间短、密封性能可靠, 并可在运行中随意进行调节, 因而广泛应用于化工、石油、食品、轻纺、宾馆与饭店等部门的热热水供应。

产品符合JB/T7387-1994。

USES and features

Self type electric temperature regulator (applicable to large diameter and heat conduction oil control), this valve the biggest characteristics just ordinary 220V power supply, the use of modulated medium own energy, directly on the steam, hot water, Heat oil and gas and the temperature of the medium implement automatic adjustment and control, you can also use to prevent overheating or heat exchange occasion, this valve of simple structure, easy operation, choose temperature range, response time Fast, reliable sealing performance, and can be adjusted at will in the operation, and widely used in chemical, petroleum, food, textile, hotel and restaurant and other departments of the hot water supply.
 Product complies with JB/T7387-1994.

结构与原理

调节阀由主阀、智能执行器与传感三部分组成, 根据用户需要, 分别有加热型与冷却型两种结构。

1. 加热型调节阀的结构与原理, 见附图示:

工作前主阀芯处于半开位置, 传感器处于自然状态。接上电源, 主阀芯全开。介质由箭头方向流入主阀体, 经阀芯对储热箱进行加热。当温度升到相应设定值时, 传感器即产生相应线性信号输入一体化智能执行机构, 随即驱动阀杆、阀芯产生位移, 关闭主阀芯停止加热。当温度低于设定值时, 传感器即产生线性信号输入执行机构, 驱使阀芯渐开, 使介质按抛物线特性流入储热箱, 进行加热直至设定值。这样被控介质始终在设定温度范围内被控制, 从而达到控温目的。

Structure and principle

Regulating valve by the main valve, intelligent actuator and sensor of three parts, according to user needs, including heating type and cooling type two kinds of structure.

1. Heating type valve, the structure and principle of saw with graphic:

Before work is in the vicinity of main valve core in position, sensor was left in a natural state. Connected to the power source, the main valve core open. Medium by the direction of arrow into the main body, the valve core to heat accumulation box to be heated. when Temperature rise to the corresponding set point, the sensor which produce the corresponding linear signal input integration intelligent actuators, and then drive valve rod, valve core produce displacement, shut of the main valve core stop heating. When the temperature is low in the set value, the sensor which produce linear signal input actuator, drive valve core gradually open, make medium according to parabolic characteristics into the heat accumulation box, heat until the set value. This was accused of medium always in setting temperature range was control, so as to achieve purpose of temperature control.

主要参数与材料 The main parameters and material

1、主要参数表 The main parameter table

公称口径(mm) Nominal diameter	15	20	25	32	40	50	65	80	100	125	150	200
公称压力(MPa) Nominal pressure	1.6 4.0											
流量能力(m ³ /h) Flow ability	5	7	10	16	25	40	63	100	160	250	400	630
额定行程(mm) Rated stroke	6		8		10		14		20		30	
温度调节范围(°C) temperature regulating range	0~120; 100~250											
调节精度(%) Control accuracy	±1~±5											
使用介质 Working medium	蒸汽、水、油、气体 Steam, water, oil, and gas											
允许泄漏量 Allow leakage	硬密封 Hard seal		10 ⁻⁴ × 阀额定容量 10 ⁻⁴ × valve rated capacity									
	软密封 soft seal		“0”									
毛细管长度 Capillary length	3m、5m、1m											
温包杆入尝试 Bulb into trying to stand	270、430、630											
联接螺纹 Connecting thread	3/4 “1”											

概述

ZMHN-16型直接作用压力调节阀，用来自动调节温度在200℃以内的非腐蚀性气体、石油、油、蒸汽压力为给定值。阀后式用来保持调节阀后面的管道内压力为恒定值。阀前式用于调节阀前面的管路内压力为恒定值。

直接作用压力调节阀由杠杆重锤膜式执行机构和调节阀两部分组成。由于它具有结构简单、动作可靠、维修方便、防火防爆和价廉的优点，广泛应用于化工、石油、冶金、电力、轻纺等工业生产过程的自动调节中。

Overview

ZMHN-16 type direct action pressure regulator, used to automatically adjust the temperature was 200°C within the non corrosion gas, oil, oil, steam pressure for a given value. After the valve type used to keep the valve behind of pipeline internal pressure is constant Fixed value. Valve used in front of the former type regulator in the pipeline pressure at a constant value.

Direct action pressure regulating valve by the lever and weight diaphragm actuators and regulator of two parts. Because it has simple structure, reliable operation, easy maintenance, fire explosion and price advantages, is widely used in chemical, petroleum, Metallurgy, electric power, textile and other industrial production processes autopilot in.

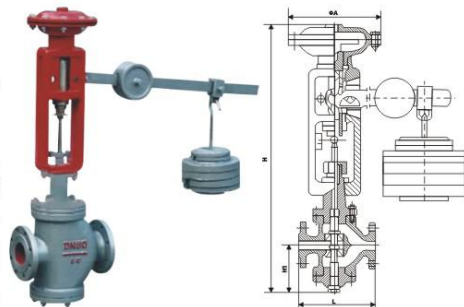

型号编制说明 Model establishment that

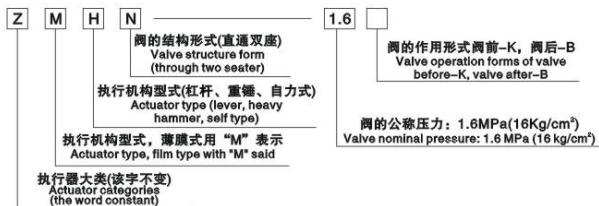

被调压力调整范围 Modulated pressure adjusting range

压力调整范围(MPa) Pressure adjustment range	薄膜装置类型 Thin film device type	膜盒外径ΦA(mm) Film box outside diameter	重锤重量(kg) Heavy hammer weight	压力调整范围(MPa) Pressure adjustment range	薄膜装置类型 Thin film device type	膜盒外径ΦA(mm) Film box outside diameter	重锤重量(kg) Heavy hammer weight
(0.15-0.65)	4	375	12	(2.5-3.5)	2	225	18
(0.65-0.85)			17	(3.5-5.0)			30
(0.85-1.0)			21	(5.0-8.0)			17
(1.0-2.0)	2	225	8	(8.0-9.5)	1	185	21
(2.0-2.5)			11	(9.5-13)			30

主要技术参数及外形尺寸 The main technical parameters and external dimensions

公称直径(mm) Nominal diameter	额定流量系数 Rated flow coefficient	最大行程(mm) Maximum stroke	公称压力(MPa) Nominal pressure	膜盒类型 Film chamber type	工作温度(℃) Working temperature	外形尺寸(mm) Physical size				
						ΦA	H	H1	H2	L
25	10	4	1.6 (16)	1 4	-20~+20	185	727	117	297	185
32	16	7					733	120	303	200
40	25						772	139	342	220
50	40						782	144	352	250
65	63						877	188	477	275
80	100						907	208	477	305
100	160					13	375	931	220	501
125	250	19				1034		270	604	410
150	400	28				1059		280	629	450
200	630					1134		320	704	550



附件系列 Accessories series

3810L、3810R 电子式电动执行器 3810L、3810R electronic electric actuator

概述 Overview

3810L、3810R系列电子式电动执行器是以220V AC单相电源作为驱动电源，配内置伺服放大器，可接受来自调节器或计算机输出的控制信号(4~20mA DC或1~5VDC)，实现直行程或角行程(0~90°)调节阀的开度控制。它还具有手动功能，极限位保护，有些还具有过力矩的保护功能。本系列电动执行器功能齐全，可靠性高，操作方便，能与各类调节阀配套，广泛应用于发电、冶金、石化、轻工及环保等工业部门的生产过程自动控制系统中。

3810L, 3810R series electronic electric actuator is 220V AC single-phase power supply as the drive power, match the built-in servo amplifier, can accept from the regulator or computer output control signals (4~20mA DC or 1~5VDC), realize straight stroke or Angle stroke (0~90°) valve open degree control system. It also has manual function, limit a protection, some also has a moment's protection function. This series of electric actuator complete function and high reliability. Easy to operate, with all kinds of regulating valve accessories, widely used in power, metallurgy, petrochemical industry, light industry and environmental protection departments of industry production process automatic control in the control system.



3810L系列直行程电动执行器

3810L series straight stroke electric actuator

型号规格 Specifications	出力 (N.m) Output force	动作时间 (s/90°) Action time	最大转角 Maximum Angle
381LSA-08 381LXA-08	80	4.2	30
381LSA-20 381LXA-20	2000	2.1	
381LSB-30 381LXB-30	3000	3.5	
381LSB-50 381LXB-50	5000	1.7	60
381LSC-65 381LXC-65	6500	2.8	
381LSC-99 381LXC-99	10000	2.0	
381LSC-160 381LXC-160	16000	1.0	100
381LSC-260 381LXC-260	26000		

3810R系列角行程电动执行器

3810R series Angle stroke electric actuator

型号规格 Specifications	出力 (N.m) Output force	动作时间 (s/90°) Action time	最大转角 Maximum Angle
381RSA-02	20	8.5	30
381RSA-05	50	17	
381RSB-10 381RXB-10	100	18	
381RSB-20 381RXB-20	200	36	
381RSC-30 381RXC-30	300	24	
381RSC-50 381RXC-50	500	42	
381RSC-60 381RXC-60	600	48	
381RSD-100	1000	30	
381RSD-150 381RSD-200 381RSD-300 381RSD-400 381RSD-500	1500	42	

主要技术参数 Main technical parameters

输入信号：4~20mA DC或1~5V DC。 输出信号：4~20mA DC(负载电阻500Ω以下)。

控制精度：基本误差±1%；回差≤1%；死区≤1%。 工作转角调整范围：零点±25%；转角20%~100%。

电源：220V AC ±15%。 50Hz额定负载时耗电功率：A型50VA；B型150VA；C型220VA。

Input signal: 4~20mA DC or 1~5V DC. Output signal: 4~20mA DC(Load resistance≤500ΩThe following).

Control accuracy: Basic error±1%; Return difference≤1%; Dead zone≤1%. Work Angle adjusting range: zero±25%; Angle20%~100%. power: 220V AC ±15%. 50HzRated load electric power: A type 50VA; B type 150VA; Ctype 220VA.

环境条件 Environmental conditions	普通型(S)执行器 Ordinary type (S type) actuator	隔爆型(X)执行器 Flameproof(X type)actuator
环境温度 Environment temperature	无空间加热器-10℃~60℃ No space heater -10℃~60℃ 有空间加热器-35℃~60℃ A space heater -35℃~60℃	-10℃~40℃
相对湿度 Relative humidity	95%以下 Below 95%	45%~85%
环境气体 Environment gas	无腐蚀性气体 No corrosive gas	
机械振动 Mechanical vibration	1.5g以下 1.5 g the following	

保护等级：IP55。隔爆等级：Exd II BT4。过载保护：规格A、B型执行器可任选，规格C型执行器必配。

Protection level: IP55. Flame-proof level: Exd II BT4. overload protection: specification of A, B type actuator can be optional, specifications C type actuator will match.

电动执行机构 Electric actuators

概述 Overview

QSL、PSQ系列电动执行机构是以220V AC单相电源作为驱动电源，配内置伺服放大器，可接受来自调节器或计算机输出的控制信号(4~20mA DC或1~5VDC)，实现直行程或角行程(0~90°)调节阀的开度控制。它还具有手动功能，极限位保护功能。

本系列电动执行器体积小、重量轻、功能齐全，可靠性高，操作方便，能与各类调节阀配套，广泛应用于发电、冶金、石化、轻工及环保等工业部门的生产过程自动控制系统中。

QSL, PSQ series of electric actuator is 220V AC single-phase power supply as the drive power, match Built-in servo amplifier, can accept from regulator or computer output control signals (4~20mA DC or 1~5VDC), realize straight stroke or Angle stroke (0~90°) valve open degree control. It also has hand Dynamic function, limit a protection function.

This series of electric actuator small volume, light weight, complete functions, high reliability, convenient operation, With all kinds of regulating valve accessories, widely used in power, metallurgy, petrochemical industry, light industry and environmental protection industry Department of production process automatic control system.



1、QSL直行程电动执行机构 QSL straight stroke electric actuators

QSL智能型直行程电动执行机构最大行程达到100mm，最大推可达25KN，适用于直行程阀门的调节和开关控制。

QSL intelligent straight stroke electric actuators maximum travel up to 100 mm, the biggest push to 25KN, suitable for direct stroke valve control and switch control.

QSL智能型直行程电动执行机构：标准型号及规格

QSL intelligent straight stroke electric actuators: standard models and specifications

标准型号 Standard model	推力 (KN) Thrust	速度 (mm/s) Speed	最大行程 (mm) Maximum stroke	电源 (V) Power	功耗 (W) Power consumption	电机保护 Motor protection	出线连接 Wire connection	手动操作 Manual operation	防护等级 Protection level	重量(Kg) weight
QSL201	1.0	0.4/1.2	50	220VAC	35	允许堵转 Allow locked-rotor	2×M20×1	手轮 Handwheel	IP67	5.5
QSL202	2.0	0.4/1.2	50	220VAC	40	允许堵转 Allow locked-rotor	2×M20×1	手轮 Handwheel	IP67	5.8
QSL204	4.0	0.4/1.2	50	220VAC	40	允许堵转 Allow locked-rotor	2×M20×1	手轮 Handwheel	IP67	6.0
QSL208	8.0	1.0	50	220VAC	80	允许堵转 Allow locked-rotor	2×M20×1	手轮 Handwheel	IP67	8.0
QSL210	10.0	1.0	50	220VAC	80	允许堵转 Allow locked-rotor	2×M20×1	手轮 Handwheel	IP67	8.2
QSL312	12.0	1.0	65	220VAC	130	热敏开关 Thermal switch	3×M20×1	手轮 Handwheel	IP65	22.5
QSL314	14.0	1.0	65	220VAC	130	热敏开关 Thermal switch	3×M20×1	手轮 Handwheel	IP65	22.5
QSL316	16.0	1.0	100	220VAC	130	热敏开关 Thermal switch	3×M20×1	手轮 Handwheel	IP65	22.5
QSL320	20.0	1.0	100	220VAC	130	热敏开关 Thermal switch	3×M20×1	手轮 Handwheel	IP65	22.5
QSL325	25.0	1.0	100	220VAC	130	热敏开关 Thermal switch	3×M20×1	手轮 Handwheel	IP65	22.5

2、QSQ系列90°角行程电动执行机构 QSQ series 90°Angle stroke electric actuators

90°角行程电动执行机构输出力矩为100Nm~700 Nm，以及1200~3000 Nm，适用于90°旋转阀门如球阀、蝶阀和风门的调节和开关控制。

90°Angle stroke electric actuator output torque for 100Nm~700Nm, and 1200~3000Nm, be applicable to the 90°rotary valves such as ball valves, butterfly valves and damper adjustment and the switch control.

电机保护 Motor protection	转矩 (Nm) Torque	90°动作时间 (s) 90°action time	输出法兰 (ISO5211) Output flange	电源 (V) Power	功耗(VA) Power consumption	出线连接 Wire connection	手动操作 Manual operation	防护等级 Protection level	重量(Kg) weight
QSQ102	100	32	F05	220VAC	62	2×M22×1.5	手轮 Handwheel	IP67	7
QSQ202	200	38	F07	220VAC	93	2×M22×1.5	手轮 Handwheel	IP67	13
QSQ502	500	43	F12	220VAC	120	2×M27×2	手轮 Handwheel	IP67	25
QSQ702	700	43	F12	220VAC	120	2×M27×2	手轮 Handwheel	IP67	25
QSQ1202	1200	31/37	F12/F14	220VAC	180	2×PF3/4*	手轮 Handwheel	IP67	70
QSQ2002	2000	93/112	F14/F16	220VAC	200	2×PF3/4*	手轮 Handwheel	IP67	75
QSQ3002	3000	93/112	F14/F16	220VAC	250	2×PF3/4*	手轮 Handwheel	IP67	75

3、可配用的内置伺服放大器PSAP4技术参数 But with built-in servo amplifier PSAP4 technical parameters:

输入信号：4~20mA，输入阻抗：250Ω
灵敏度：±(0.5~5%)F.S 重复精度：±1%
电源：220VAC 50Hz 功耗：5VA
The input signal: 4~20mA, the input impedance: 250Ω
Sensitivity: ±(0.5~5%) F.S heavy precision: plus or minus: ±1%
Power supply: 220VAC 50Hz power consumption: 5VA

输出信号：4~20mA，负载电阻≤650KΩ
驱动触点容量：150VA(24V 50VA)
环境温度：-10~700C
Output signal: 4~20mA, Load resistance≤650KΩ
Drive contact capacity: 150VA(24V 50VA)
Environment temperature: -10~700C

ZHA、ZHB气动薄膜精小型执行机构是气动薄膜精小型调节阀的驱动机构，也可代替Z_B^AM气动薄膜执行机构使用，采用多弹簧式结构，高度和重量大大减少，具有结构简单、操作方便、动作可靠，可在易燃易爆场合使用。

ZHA、ZHB气动薄膜精小型执行机构分正作用(ZHA)和反作用(ZHB)两种。

产品符合GB/T4213-1992。

ZHA、ZHB pneumatic film fine small actuator is pneumatic film fine small valve drive, also can replace Z_B^AM gas dynamic diaphragm actuator is used, the spring type structure, height and weight decrease greatly, has simple structure, convenient operation, dynamic Be reliable, can be in inflammable and explosive occasions to use.

ZHA, ZHB pneumatic film fine small actuator points are action (ZHA) and reaction (ZHB) two.

Products comply with GB/T4213-1992.



技术参数和性能

作用型式

正作用: ZHA-2、ZHA-3、ZHA-4、ZHA-5、ZHA-6

反作用: ZHB-2、ZHB-3、ZHB-4、ZHB-5、ZHB-6

注: 1.正作用执行机构: 薄膜气室供气压力增加, 执行机构推杆向下运动

2.反作用执行机构: 薄膜气室供气压力增加, 执行机构推杆向上运动

Technical parameters and performance

Mode of action

Positive role: ZHA-2、ZHA-3、ZHA-4、ZHA-5、ZHA-6

reaction: ZHB-2、ZHB-3、ZHB-4、ZHB-5、ZHB-6

Note: 1.Positive interaction actuators: film chamber air supply pressure increases, the actuator rod downward movement

2.Reaction actuators: film chamber air supply pressure increases, the actuator rod upward movement

弹簧范围 Spring range	20~100、40~200、20~60、60~100、80~240KPa
供气压力 Gas supply pressure	140~400KPa
气源接口 Air interface	M10×1
环境温度 Environment temperature	-25~+55℃
附件 Attached a	定位器、空气过滤减压阀、保位阀、行程开关、手轮机构等 Locator, air filtration pressure reducer, protect a valve, travel switch, hand wheel mechanism, etc

外形尺寸 Physical size

执行机构 Actuator	行程 Stroke	D	H	D ₁	D ₂	D ₃	N-d	M-6H	S		薄膜面积 (cm ²) Film area	重量 (kg) Heavy quantity
									ZHA	ZHB		
ZH _B ^A -22	16	280	280	60	80	100	2-10	M12×1.25	90	78	350	12
ZH _B ^A -23	25	280	307	60	80	100	2-10	M12×1.25	90	75	350	16
ZH _B ^A -34	40	360	398	80	105	130	4-12	M12×1.25	142	102	560	22
ZH _B ^A -45	60	470	523	95	118	150	4-14	M16×1.5	165	105	900	52
ZH _B ^A -56	100	580	723	100	130	170	4-18	M22×1.5	245	145	1400	100

DYR系列角行程电动执行器 DYR series Angle stroke electric actuator

概述 Overview

DYR系列角行程电动执行器是一种高品质回转型电动执行器, 设计独特、

外秀内刚, 体积小, 重量轻, 具有如下主要性能特点:

1、DYR系列与同等转矩的执行机构相比, 结构最为紧凑, 外形精巧美观, 体积与重量仅相当于同类产品的1/3左右。易安装, 且无需维护等等。

2、DYR系列电动执行机构中采用机电一体化设计, 内置伺服放大器模块,

接收计算机或仪表等输出的4~20mA DC或1~5V DC控制信号, 实现对电动阀门的精确定位控制。

3、DYR系列各种规格产品均经过了连续48小时额定负载运行试验, 确保产品的性能先进性和品质可靠性。

DYR series Angle stroke electric actuator is a kind of high quality rotary type valve electric actuator, unique design,

Outside show inside just, small volume, light weight, has the following main characteristics:

1、DYR series with the same torque of actuators, compared with the most compact structure, the appearance is delicate and beautiful, Volume and weight is only 1/3 of similar products. Easy to install, and no maintenance and so on.

2、DYR series of electric actuator using electromechanical integration design, built-in servo amplifier module,

Receiving computer or instrument and output of 4~20mA DC or 1~5V DC control signal, realize the precise localization of electric valve control.

3、DYR series products are various specifications after successive 48 hours rated load operation test to ensure the product's performance and advanced and quality reliability.



性能参数表 Performance parameter table

机型 Model	DYR-02	DYR-03	DYR-05	DYR-10
性能 Performance				
输出转矩 Output torque	20Nm	30Nm	50Nm	100Nm
90°动作时间 90°action time	4S	10S	20S/60S	15S/30S
回转角度范围 Rotation Angle range	0~360°	0~360°	0~360°	0~360°
电机功率 Motor power	10W	10W	20W	25W
整机重量 The weight of the	2kg	2kg	2kg	3kg
电源 Electric source	AC 110V、AC 220V、AC 380V、DC24V			
绝缘电阻 Insulation resistance	100MΩ/500VDC			
耐压强度 Pressure strength	1500VAC 1分钟 1500 vac for 1 minute			
防护等级 Protection level	相当于IP67 Equivalent to IP67			
安装方位 Installation bearing	360°任意角度安装 360° Installed at random Angle			
电气接口 Electrical interface	G1/2防水电缆接头、电源线、信号线各一个 G1/2 waterproof cable joint, and the power cord, each a signal			
环境温度 Environment temperature	-30℃~+60℃			
控制电路选项 Control circuit options	A型: 极限位置开关(标准型) B型: 带中间位置开关 C型: 带电位器 D型: 带电位器和中间位置开关E型: 带伺服控制器(调节型) F型: 带PI/变频器 Type A: limit position switch (standard) type B: take intermediate position switch C type: take potentiometer D type: take potentiometer and intermediate position switch E type: take servo controller (Diao.Jiao.Qing) F type: take PI converter			
可选功能 Optional feature	●过力矩保护 ●除温加热器 ●不锈钢支架、联轴器 ● A moment protection ● Deelcoat heater ● Stainless steel bracket, coupling			

机型 Model	DYR-20	DYR-40	DYR-60	DYR-100	DYR-160	DYR-200
性能 Performance						
输出转矩 Output torque	200Nm	400 Nm	600 Nm	1000 Nm	1600Nm	2000Nm
90°动作时间 90°action time	30S/60S	30S/60S	45S	30S	48S	60S
回转角度范围 Rotation Angle range	0~90°	90°	0~90°	0~90°	0~90°	0~90°
电机功率 Motor power	40W	90W	90W	120W	140W	140W
整机重量 The weight of the	8kg	8.5kg	9.0kg	17kg	17.5kg	18kg
电源 Electric source	AC 110V、AC 220V、AC 380V、DC24V					
绝缘电阻 Insulation resistance	100MΩ/500VDC					
耐压强度 Pressure strength	1500VAC 1分钟 1500 vac for 1 minute					
防护等级 Protection level	相当于IP67 Equivalent to IP67					
安装方位 Installation bearing	360°任意角度安装 360° Installed at random Angle					
电气接口 Electrical interface	G1/2防水电缆接头、电源线、信号线各一个 G1/2 waterproof cable joint, and the power cord, each a signal					
环境温度 Environment temperature	-30℃~+60℃					
控制电路选项 Control circuit options	A型: 极限位置开关(标准型) B型: 带中间位置开关 C型: 带电位器 D型: 带电位器和中间位置开关E型: 带伺服控制器(调节型) F型: 带PI/变频器 Type A: limit position switch (standard) type B: take intermediate position switch C type: take potentiometer D type: take potentiometer and intermediate position switch E type: take servo controller (Diao.Jiao.Qing) F type: take PI converter					
可选功能 Optional feature	●过力矩保护 ●除温加热器 ●不锈钢支架、联轴器 ● A moment protection ● Deelcoat heater ● Stainless steel bracket, coupling					

RT型气动执行器 RT type pneumatic actuator

概述 Overview

- 1、相同规格有双作用式、单作用式(弹簧复位)。
- 2、标准旋转角度可调节-5~+50范围。
- 3、所有滑动部件采用塑料轴承衬套、导向,保持最小摩擦力,并有效地抵抗磨损。
- 4、外壳表面阳极化电镀,防腐蚀保护;旋转轴镀硬铬磷合金;螺丝、螺母为不锈钢。
- 5、单作用式弹簧预装在弹簧座内,很容易装配或增补弹簧数量。
- 6、连接、安装接口标准化模块设计,方便配套球阀、蝶阀、信号盒及控制附件。
- 7、可选择旋转方向顺时针或逆时针旋转;两端调节螺丝可调节小于标定角度调整。
- 8、特殊的腐蚀环境可采用不锈钢外壳。

- 1、The same specifications have double acting and single acting (spring reset).
- 2、Standard axis of rotation Angle adjustable -5~+50 range.
- 3、All sliding parts using plastic bearing bushing, guide, maintain minimum friction and effectively abrasion resistance.
- 4、Shell surface anodized electroplating, anti-corrosion protection; Axis plating hard nickel phosphorus alloy; screw, nut for stainless steel.
- 5、Single acting spring pre-installed in the spring seat inside, it is easy to assemble or supplementary spring quantity.
- 6、Connection and installation interface standardized module design, convenient compatibility ball valves, butterfly valves, signal box and control accessories.
- 7、Can choose direction of rotation clockwise or anti-clockwise rotation; Both ends adjusting screw adjustable less than calibration angle adjustment.
- 8、Special corrosive environment can use stainless steel shell.



双作用执行器 Double acting actuators

CCW

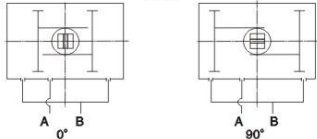

A口进气,压缩空气推动活塞向外运动,使执行器输出轴逆时针旋转(0°-90°),B口排气。
B口进气,压缩空气推动活塞向内运动,使执行器输出轴顺时针旋转(90°-0°),A口排气。

A mouth intake, compressed air to promote piston outward movement, make the actuator output shaft Inverse time Needle rotation (0°-90°), B mouth exhaust.
B mouth intake, compressed air to promote piston inward movement, make the actuator output shaft on time Needle rotation (90°-0°), A mouth exhaust.

CW

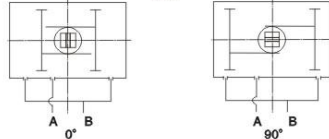

A口进气,压缩空气推动活塞向外运动,使执行器输出轴顺时针旋转(0°-90°),B口排气。
B口进气,压缩空气推动活塞向内运动,使执行器输出轴逆时针旋转(90°-0°),A口排气。

A mouth intake, compressed air to promote piston outward movement, make the actuator output shaft on time Needle rotation (0°-90°), B mouth exhaust.
B mouth intake, compressed air to promote piston inward movement, make the actuator output shaft Inverse time Needle rotation (90°-0°), A mouth exhaust.

双作用执行器输出力矩(Unit:Nm) Double action actuator output torque

型号 Model	输入气源压力(单位:巴) Input air pressure (unit: ba)									
	2	2.5	3	4	4.5	5	5.5	6	7	8
RT020DA	8.0	10.0	12.0	16.0	18.0	20.0	21.9	23.9	27.9	31.9
RT035DA	14.6	18.2	21.9	29.2	32.8	36.5	40.1	43.8	51.1	58.4
RT050DA	20.1	25.1	30.1	40.1	45.1	50.2	55.2	60.2	70.2	80.3
RT075DA	31.4	39.2	47.0	62.7	70.5	78.4	86.2	94.1	109.7	125.4
RT110DA	45.1	56.4	67.7	90.3	101.6	112.9	124.1	135.4	158.0	180.6
RT160DA	66.1	82.7	99.2	132.2	148.8	165.3	181.8	198.4	231.4	264.5
RT255DA	100.3	125.4	150.5	200.6	225.7	250.8	275.9	301.0	351.1	401.3
RT435DA	171.0	213.8	256.5	342.0	384.8	427.5	470.3	513.0	598.5	684.0
RT665DA	266.0	332.5	399.0	532.0	598.5	665.0	731.5	798.0	931.0	1064.0
RT1000DA	425.6	532.0	638.4	851.2	957.6	1064.0	1170.4	1276.8	1489.6	1702.4
RT1200DA	532.0	665.0	798.0	1064.0	1197.0	1330.0	1463.0	1596.0	1862.0	2128.0
RT1800DA	769.5	961.9	1154.3	1539.0	1731.4	1923.8	2116.1	2308.5	2693.3	3078.0
RT2700DA	1169.6	1462.1	1754.5	2339.3	2631.7	2924.1	3216.5	3508.9	4093.7	4678.6

RT型气动执行器 RT type pneumatic actuator

双作用执行器的选型 Double action actuator selection

在正常操作条件下,双作用执行器考虑的安全系数为20%-30%。
示例:

阀门力矩=100Nm
安全力矩=100×(1+30%)=130Nm
气源压力=5Bar

对照双作用力矩表,选配双作用执行器最小规格为RT160DA。

In normal operation condition, the double action actuator consider safety coefficient is 20%-30%.

sample:

Valve moment = 100Nm
Safety moments = 100 × (1 + 30%) = 130Nm
Air pressure = 5Bar

Control double-acting moment table, matching double acting actuators for minimum specifications RT160DA.

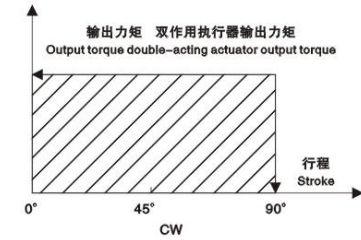

单作用执行器 Single acting actuators

CCW

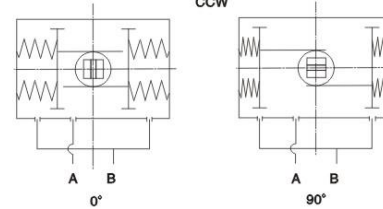

A口进气,压缩空气克服弹簧力,推动活塞向外运动,执行器输出轴逆时针转动(0°-90°),B口排气;

执行器失气,活塞在弹簧力的作用下向内运动,执行器输出轴顺时针转动(90°-0°),A口排气。

A mouth intake, compressed air overcome spring force, promote the piston outward movement, actuator lose The counter-clockwise rotation (0°-90°), B mouth exhaust;
Actuator loss of air pressure, piston in the spring under the action of forces inward movement, actuator output shaft Clockwise rotation (90°-0°), A mouth exhaust.

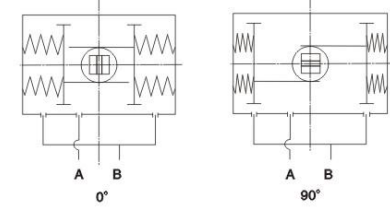

A口进气,压缩空气克服弹簧力,推动活塞向外运动,执行器输出轴顺时针转动(0°-90°),B口排气;

执行器失气,活塞在弹簧力的作用下向内运动,执行器输出轴逆时针转动(90°-0°),A口排气。

A mouth intake, compressed air overcome spring force, promote the piston outward movement, actuator lose The counter-clockwise rotation (0°-90°), B mouth exhaust;
Actuator loss of air pressure, piston in the spring under the action of forces inward movement, actuator output shaft Anti-clockwise rotation (90°-0°), A mouth exhaust.

单作用执行器输出力矩 Single acting actuators output torque

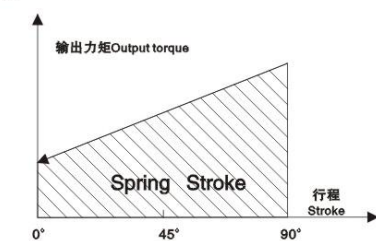
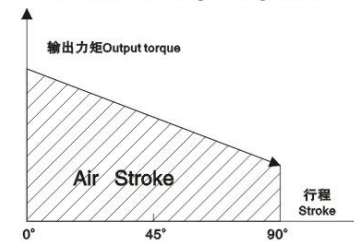

RT型气动执行器 RT type pneumatic actuator

单作用执行器的选型 Single-acting actuator selection

在正常工作条件下, 单作用执行器考虑的安全系数为30%~50%
Under normal working conditions, single acting actuators consider safety coefficient was 30%~50%

例如:

阀门需要力矩=80N.m
安全力矩=80(1+30%)=104N.m
气源压力=5Bar
对照单作用执行器输出力矩表, 我们可以查到RT435SR
K7输出力矩为

空气行程0°=308N.m
空气行程90°=247N.m
弹簧行程90°=181N.m
弹簧行程0°=120N.m

所有输出力矩均大于我们需求。

注意 Note:

单作用执行器弹簧复位过程中, 执行器B口通气不影响执行器输出力矩, 相反帮助弹簧的复位。
Single acting actuators spring reset process, actuator ventilation port B does not affect the actuator output torque, on the contrary help spring reset.

例如:

蝶阀原最大扭矩=104N.m
打开后扭矩104x30%=32N.m
气源压力=5Bar

我们可以选择RT255SR K11

空气行程0°=136N.m>104N.m
空气行程90°=78N.m>32N.m
弹簧行程90°=173N.m>104N.m
弹簧行程0°=115N.m>104N.m

以上数据显可以显示可以满足该蝶阀的正常启闭。

For example:

Valve need moment=80N.m
Safety moment=80(1+30%)=104N.m
Air pressure=5Bar
Control the single-acting actuator output torque table, we can find RT435SR
K7 Output torque for

Air travel0°=308N.m
Air travel90°=247N.m
Air travel90°=181N.m
Air travel0°=120N.m

All output torque is more than we need.

For example:

Butterfly valve original peak torque=104N.m
Opened torque104x30%=32N.m
Air pressure=5Bar

We can choose RT255SR K11
Air travel0°=136N.m>104N.m
Air travel90°=78N.m>32N.m
Air travel90°=173N.m>32N.m
Air travel0°=115N.m>104N.m

The data above shows that can satisfy the normal opening and closing the butterfly valve.

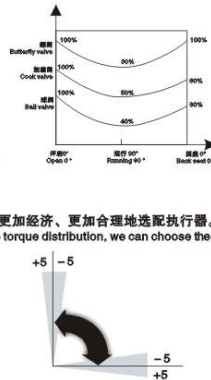

单作用执行器弹簧安装形式 Single acting actuators spring installation form

在单作用执行器的选型过程中, 如果能够了解阀门在开启、运行和关闭时的扭矩分配, 我们就可以更加经济、更加合理地选配执行器。
In the single acting actuators matching process, If can understand the valve opening, operating and closing the torque distribution, we can choose the more reasonable and more economical actuators is optional.

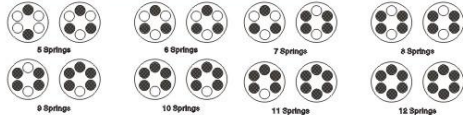

工作技术条件

- 1、工作介质: 干燥或润滑的空气或无腐蚀性气体介质中杂质微粒小于30 μm。
- 2、气源压力: 最小气源压力2.5巴, 最大气源压力8巴。
- 3、介质环境温度: 标准: -20℃~+80℃
低温: -35℃~+80℃ 高温: -15℃~150℃
- 4、行程调节: 0°和90°两个位置有±5°的调节范围
- 5、使用场合: 室内或室外安装

动作形式 Action form

单作用和双作用 Single function and double action

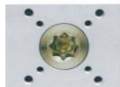

气源接口符合NAMUR标准, 可简单方便地安装电磁阀。
Is designed in accordance with NAMUR standard, Can be easy and convenient to install solenoid valve.

底部安装孔设计符合ISO5211, DIN3337标准, 可以直接安装离合器(气动手轮机构)或安装支架。
Bottom mounting hole design accords with ISO5211, DIN3337 standard, Can be directly mounted clutch (pneumatic handwheel institutions) or mounting bracket.

输出轴的NAMUR标准槽和缸体上部标准安装孔, 可使限位开关、定位器直接吻合和安装。
Output shaft NAMUR standard tank and cylinder block upper standard mounting hole, Can make the limit switch, locator direct engagement and installation.

Work technical conditions

- 1、Working medium: Dry or lubricated air or inert gas medium impurity particles less than 30 μm.
- 2、Air pressure: Minimum air pressure 2.5 Paikatan, Maximum air pressure 8 Paikatan.
- 3、Medium environment temperature: standard: -20℃~+80℃
Low temperature: -35℃~+80℃ High temperature: -15℃~150℃
- 4、Stroke control: 0°and 90°Two position ± 5°Adjusting range of
- 5、The usage situation: Indoor or outdoor installation

概述

普通机械式定位器以其结构简单, 维护方便, 易于操作, 价格低廉等优点一直稳居市场主导地位。我们根据近年来国内、国际市场和用户不断变化的要求, 重新改进设计推出HY(HEP)电-气阀门定位器, 它不仅延续了原来设计的一些优点。而且在安装、调试、使用和维护上都有较大的提高。适用范围更广, 高度更方便、快捷。

Overview

Common mechanical locator with its simple structure, easy maintenance, easy to operate, price is low wait for an advantage has been stable The leading position in the market. We according to the recent years domestic and international market and users constantly changing requirements, set to Improve Meter out HY (HEP) electric-pneumatic valve positioner, It not only continue the original design of some advantages. And in installation and adjustment Test, use and maintenance has large improvement. Which has more extensively applicable scope, highly more convenient, fast.



特点

适用范围更广: 采用了新型结构继动器。使定位器工作压力范围直接扩展到0.14~0.5MPa范围, 无需再分高低压, 提高了通用性, 更方便用户的使用。

配用执行器更方便: 重新设计的新型继动器, 只需通过调节节流螺钉, 就可满足不同空气容量的各种执行器供气要求。再无需调换继动器节流板等复杂的拆装工作。

大小行程的方便使用: 新设计中采用了分体式反馈杠杆结构。在任何条件下都可以方便更换。而且无需专业知识再去调整相对位置。更不会因为更换反馈行程杆不当而影响精度和使用。

接线盒和防爆密封一体结构: 安装更加方便, 接线更加简单、快捷。

Characteristics

Which has more extensively applicable scope: adopts the new type of structure servomotor. Make locator working pressure range direct spread to 0.14~0.5MPa range, need not points high and low pressure, improve the generality, more convenient The use of user.

With actuator more convenient to design new servomotor, only through the adjustment throttle screw, can meet the different air capacity of the various actuator air requirement. No longer need not exchange relay Device throttle plate and complex dismantling work.

Size stroke convenient use: new design with a separated feedback lever structure. In any conditions can be convenient change. And also need not professional knowledge to adjust the relative position. more Won't because of changing feedback stroke rod Improper influence accuracy and use.

Terminal box and explosion-proof seal one structure: more convenient installation, wiring more simple, quick.

型号说明 Model shows

HY(HEP)-

型号 Model	作用形式 Function form	防爆(防护)结构等级 Explosion-proof (protection) structure level	动作形式 Action form	选用配件 Choose accessories
HY(HEP)-	1 单作用 single-acting	5 隔爆型ExdII BT6 Flameproof ExdII BT6	1 直行程 Straight stroke	<input type="checkbox"/>
	2 双作用 Double action	6 本安型ExdII CT6 The Ann type ExdII CT6	RC 角行程(配RC执行机构) Angle stroke (with RC actuator)	<input type="checkbox"/> +PTM(内置阀位反馈) + PTM (built-in valve position feedback)
		7 普通型 Ordinary		

订货时请写明: 1、型号 2、输入信号 3、供气压力 4、作用形式 5、防爆等级 6、动作形式 7、选用配件

When ordering, please indicate: 1, type 2, the input signal 3, gas supply pressure 4, function form 5, explosion-proof grade 6, action form 7, choose accessories

YT-1000系列电气阀门定位器 YT-1000 series electric valve positioner

概述

(YT)-1000系列电-气阀门定位器是引进国外先进技术生产制造的成功产品。它与气动调节阀配套使用，构成闭环控制回路，从控制器或控制系统中输出的电流信号转换成驱动调节阀的气信号。控制调节阀的动作。同时根据调节阀开度进行反馈，使阀门位置能够按系统输出的控制信号进行正确定位。该定位器可用于单作用型和双作用型气动执行机构。

Overview

(YT)-1000 series electric-pneumatic valve positioner is the introduction of advanced foreign technology produce manufacturing success products. It and supporting the use of pneumatic valve, constitute a closed loop control loop, from controller or control system of electrical output Flow signal into drive control valve of the gas signal. Control valve action. At the same time according to the valve opening into Line feedback, make the valve position can according to the system output control signals for the correct localization. The positioning device can be used for Single function type and double action type pneumatic actuators.

特点

- 具有高抗振性(在50-200Hz范围内无共振现象)。
- 电气接口均为多孔形式，便于任意方向连接。
- 调校简单，易于实现正、反作用的转换。
- 对于小型执行机构，可通过调节气孔来消除振荡现象。
- 不用换零部件就可以实现1/2范围内分程控制。
- 易于反馈连接。
- 空气消耗量少，经济性好。

Characteristics

- Fox has high vibration sex (In 50-200Hz range no resonance phenomenon).
- electrical Interface are porous form, facilitate any direction connection.
- Set-up - simple, easy to realize positive and reaction conversion.
- For small fox executive mechanism, and can adjust the hole to eliminate oscillation phenomenon.
- don't change parts can be achieved 1/2 range points process control.
- easy to feedback connection.
- air consumption less, the economy is good.



型号说明 Model shows

HY(HEP)-

型号 Model	动作形式 Action form	作用形式 Function form	防爆等级 Explosive-proof grade	反馈形式 Feedback form	先导阀排气孔 Pilot valve vent	选项 Options
YT-1000	1 直行程 Straight stroke	S 单作用 Single-acting	S Exdm II BT6	1 10-40mm (直行程) Straight stroke 角行程 Angle stroke	1 执行机构容积 小于90cm ³ Actuator volume Less than 90cm ³	0 无No
	2 角行程 Angle stroke	D 双作用 Double action	D Exdm II CT6	3 70-100mm (直行程) Straight stroke 角行程 Angle stroke	3 执行机构容积 大于180cm ³ Actuator volume More than 180cm ³	2 +PTM (外置限位反馈) + PTM (external valve position feedback)
	3 角行程 Angle stroke	非防爆 Not explosion-proof	I Exia II BT6	4 130-150mm (直行程) Straight stroke 角行程 Angle stroke	4 100-130mm (直行程) Straight stroke 角行程 Angle stroke	4 +L/S (外置限位开关) + L/S (the outer limit switch)

订货时请写明：1、型号 2、输入信号 3、供气压力 4、作用形式 5、防爆等级 6、配减压器

When ordering, please indicate: 1, type 2, the input signal 3, gas supply pressure 4, function form 5, explosion-proof grade 6, with pressure reducer

QFH型系列空气过滤器 QFH type series air filter

概述

QFH型系列空气过滤器是气动仪表的辅助装置之一。将来自空气压缩机0.3-1MPa的空气压力，经过滤净化后，可调节在0-0.16、0-0.25、0-0.4、0-0.6MPa范围内任一输出压力值，保持稳定。作为各类气动仪表的气动自动装置的气源压力提供给单元以及其他气动设备的附属装置。

Overview

QFH type series air filter is pneumatic instrument is one of the auxiliary device. Will come from air compressor 0.3-1 mpa air pressure, after LvJingHua, adjustable in 0-0.16、0-0.25、0-0.4、0-0.6 MPa range any output pressure value, maintain the stability. As all kinds of pneumatic instrument air Automatic device air pressure to provide unit and other pneumatic equipment accessory device.

性能及型号规格

1、工作环境条件

减压器应在下述环境条件下正常工作：(1)温度为-25~+55℃；(2)相对湿度5%~95%；(3)振动频率不大于25Hz，振幅不大于0.5mm；

(4)空气中不应含有对减压器起腐蚀作用的有害杂质。 2、减压器的基本参数及尺寸见下表所示：

Performance and specifications

1, work environment conditions

Pressure relief valve should be able to in the following conditions normal work: (1) temperature for -25~+55℃; (2) the relative humidity 5%-95%; (3) vibration frequency is not big in 25Hz, amplitude is not more than 0.5mm;

(4) the air should not contain to pressure reducer corrode of harmful impurity. 2, decompressor basic parameters and size see table below shows:

项目 Item	型号 Type	QFH-111	QFH-211	QFH-212	QFH-213	QFH-221	QFH-222	QFH-223	QFH-241	QFH-243	QFH-261	QFH-263
气源压力(MPa) Air pressure		0.3-0.7				0.4-0.7			0.5-1.0		0.7-1.0	
最大输出压力(MPa) Maximum output pressure		0.16				0.25			0.4		0.6	
最大输出流量(m ³ /h)标准 状态 Maximum output flow (m ³ /h) Standard state		3	12	40	3	12	40	3	40	3	40	40
接管内螺纹 Over internal thread		M10×1	G1/2"	G3/4"	M10×1	G1/2"	G3/4"	M10×1	G3/4"	M10×1	G3/4"	G3/4"



IL-201型气动锁止阀(保位阀) IL-201 type pneumatic lock valve (similar to a valve)

概述

IL-201型气动锁止阀是气动单元组合仪表辅助单元之一。当仪表气源系统发生故障时，锁止阀能自动切断调节阀与阀门的通道，使阀门保持在原来位置，以保证工艺过程的正常进行，直到气源消除后，恢复正常工作。因此，气动锁止阀适用于重要自动控制回路中作为安全保护装置。

Overview

IL-201 type pneumatic lock valve is pneumatic unit combination instrument one of auxiliary unit. When the instrument air supply system is at fault, Lock valve can automatically cut off the regulator and the valve channel, so that the valve to keep in the original position, in order to ensure the normal process, until the air is eliminated, the normal work. Therefore, pneumatic lock valve suitable for important automatic control circuit as Safety protection device.

主要技术参数及性能

环境温度：-20~+60℃，相对湿度≤95% 环境振动频率：≤25Hz，振幅<0.2mm 给定力调整范围：0.8-2.5kg/cm² 通道压力：0.2-2kg/cm²
灵敏度：≤0.15kg/cm² 通道流量：≥1.5m³/h

The main technical parameters and performance

Environment temperature：-20~+60℃, Relative humidity≤95% Environmental vibration frequency：≤25Hz, Amplitude<0.2mm To the concentration range of adjustment：0.8-2.5kg/cm² Channel pressure：0.2-2kg/cm² Sensitivity：≤0.15kg/cm² Channel flow：≥1.5m³/h



特点

- 1、压铸铝合金壳体、粉末涂层，外观美观，质量可靠。
- 2、开关位置可由指示器清楚辨识。
- 3、快速定位凸轮，通过花键轴和弹簧安装，不用工具即可方便调整。
- 4、多接点端子排，有8个标准接点，接地安全、方便。
- 5、标准的电线接口。
- 6、防脱螺栓，拆装时螺栓附在上盖上不会脱落。
- 7、安装方便，不锈钢主轴连接部分及安装支架均符合NAMUR标准。



Characteristics

- 1、Die casting aluminum alloy shell, powder coating, the outward appearance is beautiful, reliable quality.
- 2、Switch position by indicator clear identification.
- 3、Rapid setting cam, through the spline shaft and spring installation, need not tools can convenient adjustment.
- 4、Multi-junction terminal row, eight standard contact, earthing safety, convenient.
- 5、Standard wire interface.
- 6、And overhand bolt, dismounting when bolt attached to the upper cover will not fall off.
- 7、Convenient installation, stainless steel shaft connection part and to the mounting bracket are in line with NAMUR standard.

技术参数和性能 Technical parameters and performance

型号 Model	APL-3N系列 APL-3 n series		APL-4N系列 APL-4 n series		APL-5N系列 APL-5 n series	
	标准 Standard	选项 Options	标准 Standard	选项 Options	标准 Standard	选项 Options
壳体 Shell	IP67		IP67ExdII BT6(EN50014/50018)		IP67ExdII CT8(EN50014/50018)	
环境温度 Environmental temperature	-25℃ ~ +85℃					
接线端口 Connection port	2X1/2NPT	PT1/2, PF1/2 M20.PG13.5	2X3/4NPT	PT3/4 PF3/4	2X3/4NPT	PT3/4 PF3/4
接线端子 Terminal	8	9~24	8	9~24	8	9~24
位置指示 Position indicator	0~90	0~180	0~90	0~180	0~90	0~180
微型开关 Micro switch	开-黄; 关-红 Open - yellow; Shut - red					
电位计 Potentiometer	机械式、感应式、弹簧接近式 Mechanical, induction, spring proximity					
电流反馈 Current feedback	1K ohm(0~5K ohm, 0~10K ohm)					
	4~20mA.DC(20~4mA.DC)					

型号说明 Model shows

APL

型号 Model

壳体 Shell

微型开关 Micro switch

N 指示器外壳为螺栓固定 For bolted

支架 Support

APL 3 气候防护型(IP67) Climate protection type (IP67)

10 2-SPDT(机械式) Mechanical

A 普通型限位开关(侧面安装) Ordinary limit switch (side mounting)

30X80 H:20~30

4 隔爆型(Exd II BT6) Flameproof (Exd II BT6)

11 3-SPDT(机械式) Mechanical

B 普通型限位开关(侧面安装) Ordinary limit switch (side mounting)

30X130 H:30~50

5 隔爆型(Exd II CT6) Flameproof (Exd II CT6)

12 4-SPDT(机械式) Mechanical

C 防爆型限位开关(底部安装) Explosion-proof limit switch (bottom installation)

30X80 H:30

13 2-SPST(机械式) Mechanical

14 2-DPDT(机械式) Mechanical

15 2-SPDT+电位计 potentiometer (机械式) Mechanical

16 2-SPDT+电流反馈 Current feedback (4~20mA.DC)(感应式) Induction

20 P&F.NJ2-V3-N (感应式) Induction

21 Autronics.PS17-5DNU (感应式) Induction

22 P&F.NJ412GM-N (感应式) Induction

23 NBB2-V3(感应式) Induction

30 一般型(弹簧接近式) General type (spring proximity)

31 高温型(100℃)(弹簧接近式) Type high temperature (100℃) (spring proximity)

H: 指气动执行装置上部输出轴的高度
H: refers to the pneumatic actuators upper output shaft height

调节阀流量系数计算 Regulating valve flow coefficient calculation

流量系数Kv计算

调节阀的额定流量系数Kvs(或称流通能力),是调节阀的重要参数。它反映流体通过调节阀的能力,亦即反映了调节阀的容量。根据计算出的流量系数Kv值的大小,选择阀的额定流量系数Kvs,就可以确定调节阀的公称口径。如果选择的Kvs过大,就会使调节阀经常工作在小开度的情况下,影响控制质量,引起振荡和噪音,使阀不在正常工作状态下工作,无法满足工艺条件,缩短阀的使用寿命。相反,如果选择的Kvs过小,则会使调节阀开度过大,阀门超负荷运行,不能满足流量要求,容易出现事故,造成不必要的浪费。为了合理选择调节阀的尺寸,必须正确计算调节阀的流量系数Kv值。

调节阀的额定流量系数Kvs值定义是:在规定的条件下,即阀的两端压差为10⁵Pa,流体密度为1g/cm³时,额定行程时流经调节阀以m³/h或t/h的流量数。

Flow coefficient Kv calculation

Control valve of the rated flow coefficient Kvs (or called flow capacity), is the important parameters of regulating valve. It reflects fluid through the regulator ability, which reflect the regulating valve capacity. According to the calculation The flow coefficient Kv value size, selection of the valve rated flow coefficient Kvs, can determine the regulator of nominal diameter. If the selected Kvs is too big, can make the control valve often working in the small open degree Under the condition of quality control effect, causing oscillation and the noise, lengthen the valve is not working normally work, cannot satisfy the process conditions and shorten valve life. On the contrary, if choose Kvs Too small, it will make the valve open through big, valve overload operation, can't meet the flow requirements, is easy to appear the accident, resulting in unnecessary waste. In order to rationally choose valve size, will Must correct calculation of the regulating valve flow coefficient Kv value.

Control valve of the rated flow coefficient Kvs value definition is: under prescribed conditions, namely valve at both ends of the differential pressure for 105 Pa, fluid density for 1 g/cm³, rated trip through the control valve to m³/h or t/h flow number.

一般液体的Kv值计算

(a)非阻塞流

判别式: $\Delta P < 0.81(P_1 - FFPV)$

流量系数计算公式: $Kv = 10QL \sqrt{\frac{r}{P_1 - P_2}}$

式中: FF—液体临界压力比系数

$FF = 0.96 - 0.28 \sqrt{P_v/P_c}$

Pv—阀入口温度下,介质的饱和蒸汽压(绝对压力)。

查《流量测量节流装置的设计安装和使用》(GB2624-81)或理化数据手册。

Pc—热力学临界压力(绝对压力)。查表同Pv。

QL—液体流量m³/h。

r—液体比重g/cm³。

P1—阀前压力(绝对压力)KPa。

P2—阀后压力(绝对压力)KPa。

(b)阻塞流

判别式: $\Delta P < 0.81(P_1 - FFPV)$

流量系数计算公式: $Kv = 10QL \sqrt{\frac{r}{0.81(P_1 - FFPV)}}$

由上式可以看出,在阻塞流情况下,Kv值的计算公式

有变化,压差一项用0.81(P1-FFPV)代替实际压差P1-P2。

这样,比用实际压差计算出的Kv值要大,也就是说,由于

阻塞流的作用,使用阀的流通能力不能充分发挥,必须按

更大的Kv值来选择阀的口径,才能满足流量的要求。

General liquid Kv value calculation

(a) non-blocking flow

Discriminant: $\Delta P < 0.81(P_1 - FFPV)$

Flow coefficient calculation formula: $Kv = 10QL \sqrt{\frac{r}{P_1 - P_2}}$

Type: FF—liquid critical pressure ratio coefficient

$FF = 0.96 - 0.28 \sqrt{P_v/P_c}$

Pv—Valve inlet temperature, Medium saturated vapor pressure(Absolute pressure).

check 《The flow measurement throttle device design Installation and use》(GB2624-81) or

physical and chemical data manual.

Pc—thermodynamic critical pressure (absolute pressure). Look-up table with Pv.

QL—liquid flow m³/h.

r—liquid weight g/cm³.

P1—valve former pressure (absolute pressure) KPa.

P2—valve after pressure (absolute pressure) KPa.

(b) blocking flow

Discriminant: $\Delta P < 0.81(P_1 - FFPV)$

Flow coefficient calculation formula: $Kv = 10QL \sqrt{\frac{r}{0.81(P_1 - FFPV)}}$

The type can see, in blocking flow cases, Kv value calculation formula Have change,

differential pressure with a 0.81 (P1 - FFPV) instead of the actual pressure differential P1 -

P2. In this way, than with the actual pressure differential calculated Kv value, that is to say,

because Blocking flow effect, use the flow capacity of the valve is not fully play, must according to

More Kv value to choose valve diameter, can meet the requirements of the flow.

气体的Kv值计算

气体与液体不同，它具有可压缩性，气体流过调节阀后，重度变小，不能再用液体公式来计算(液体公式以流经调节阀前后液体的重度不变为前提)。关于气体的Kv值计算方法，目前有阀前重度法，阀后重度法，平均重度法，压缩系数法等多种方法。因为平均重度法的计算结构比较接近实验数据，故应用最多。我们这里推广采用平均重度法来计算气体的Kv值。

Gas Kv value calculation

Gas and liquid are different, it has the compressibility, gas flow control valve, severe decrease, can't use liquid formula to calculate formula (liquid to liquid flows through regulating valve and severe unchanged as the prerequisite). About gas Kv value calculation method, there are severe method before valve, valve after severe method, average severe method, compression coefficient method and so on the many kinds of methods. Because the average severe method of structure is calculated close to the experimental data, the application of the most. We here promotion use average severe method to calculate gas Kv value.

当P2>0.5P1时

$$Kv = \frac{Qg}{4.73} \sqrt{\frac{G(273+t)}{\Delta P \cdot Pm}}$$

式中: Qg—标准状态下气体流量m³/h

$$Pm = \frac{P1 - P2}{2} \text{ KPa}$$

$$\Delta P = P1 - P2 \text{ KPa}$$

G—气体比重 空气G=1
t—气体温度℃

当P2≤0.5P1时

$$Kv = \frac{Qg}{2.90P1} \sqrt{G(273+t)}$$

式中: Qg—标准状态下气体流量m³/h

$$Pm = \frac{P1 - P2}{2} \text{ KPa}$$

$$\Delta P = P1 - P2 \text{ KPa}$$

G—气体比重 空气G=1
t—气体温度℃

When P2>0.5P1 Time

$$Kv = \frac{Qg}{4.73} \sqrt{\frac{G(273+t)}{\Delta P \cdot Pm}}$$

Type: Qg—standard state gas flow m³/h

$$Pm = \frac{P1 - P2}{2} \text{ KPa}$$

$$\Delta P = P1 - P2 \text{ KPa}$$

G—gas proportion air G=1
t—gas temperature℃

When P2≤0.5P1 Time

$$Kv = \frac{Qg}{2.90P1} \sqrt{G(273+t)}$$

Type: Qg—standard state gas flow m³/h

$$Pm = \frac{P1 - P2}{2} \text{ KPa}$$

$$\Delta P = P1 - P2 \text{ KPa}$$

G—gas proportion air G=1
t—gas temperature℃

蒸汽的Kv值计算

(a)饱和水蒸汽

当P2>0.5P1时

$$Kv = 6.23Gs \sqrt{\frac{1}{(P1+P2)(P1-P2)}}$$

式中: Gs—蒸汽流量(kg/h)

P1、P2含义及单位同前。

当P2≤0.5P1时

$$Kv = \frac{7.25Gs}{P1}$$

Steam Kv value calculation

(a) saturation vapor

When P2 > 0.5 when P1

$$Kv = 6.23Gs \sqrt{\frac{1}{(P1+P2)(P1-P2)}}$$

Type: Gs—steam flow (kg/h)

P1, P2 unit of meaning and with the former.

当P2≤0.5P1时

$$Kv = \frac{7.25Gs}{P1}$$

(b) a hot water steam engine

When P2>0.5P1 Time

$$Kv = 6.23Gs \sqrt{\frac{1+0.0013\Delta t}{(P1+P2)(P1-P2)}}$$

Type of: Δt—Steam superheat℃

when P2≤0.5P1 Time

$$Kv = \frac{7.25Gs}{P1} \sqrt{1+0.0013\Delta t}$$

P1, P2 unit of meaning and with the former

调节阀的口径选择

一般的选择步骤

- 根据生产能力、设备负荷计算出最大流量和最小流量Qmax、Qmin。
- 根据系统特点、压力分配和管路损失，确定最大压差和最小压差ΔPmax、ΔPmin。
- 按流量系数计算公式，求得最大流量和最小流量时的Kvmax、Kvmin。
- 根据求出的Kvmax，在产品样本中选取大于Kvmax，并最接近Kvmax的Kvs值。
- 由计算出的Kvmax、Kvmin换算阀的开启度(可按直线特性换算开度，一般要求阀开度在10%~70%之间)。
- 各项计算验证合格后，根据Kvs值，确定调节阀的公称口径DN。

Valve size selection

The choice of general steps

- according to the production capacity, equipment load to calculate the maximum flow and minimum flow Qmax, Qmin.
- According to the system characteristics, pressure distribution and line loss, determination of the maximum pressure differential and the minimum differential pressure ΔPmax, ΔPmin.
- according to the flow coefficient calculation formula, get maximum flow and minimum flow of Kvmax, Kvmin.
- according to find out the Kvmax, in the product sample selection in more than Kvmax, and the most close to the Kvmax Kvs value.
- by calculated Kvmax, Kvmin check valve opening (according to linear characteristic check opening, general requirements valve opening between 10%~70%).
- the results demonstrate conformity, according to Kvs value, to determine the nominal size of the regulating valve DN.

名称 Name	分子式 Molecular formula	分子量 Molecular weight	气体常数 Gas constant R kg·m kg·K	密度 ρ 0kg/mm ³ Density ρ 0kg/mm ³		比重在0℃ 760mmHg下 (空气=1) Specific gravity at 0℃, 760 mmHg (air=1)	沸点TbK 在760 mmHg下 Boiling point TbK in 760 mmHg the	比热比γ在 20℃及 760mmHg 下 Specific heat ratio γ at 20 and 760mmHg under	临界点 Critical point		
				在0℃,760 mmHg下	在20℃,760 mmHg下				温度Tc K Temperature	压力Pc kg/cm ² Pressure	密度 ρc kg/m ³ Density
空气 Air (干) (Dry)		28.96	29.28	1.2928	1.205	1.00	78.8	1.4*	132.42~ 132.52	38.4	328~ 320
氮 Nitrogen	N2	28.0134	30.27	1.2506	1.165	0.9673	77.35	1.4*	126.1	34.6	312
氧 Oxygen	O2	31.9988	26.5	1.4289	1.331	1.1053	90.17	1.397*	154.78	51.7	426
氩 Argon	Ar	39.948	21.23	1.7840	1.38	0.668	87.291	1.68	150.7	49.6	535
氖 Neon	Ne	20.183	42.02	0.9000		0.6062	27.09	1.68	44.4	27.8	483
氦 Helium	He	4.003	211.84	0.17847		0.1380	4.215	1.66	5.199	2.34	89
氪 Krypton	Kr	83.40	10.12	3.6431		2.818	119.79	1.67	208.4	56.1	909
氙 Xenon	Xe	131.30	6.46	5.89		4.53	165.02	1.666	289.75	59.9	1105
氢 Hydrogen	H2	2.016	420.63	0.08988	0.084	0.06952	20.38	1.412*	32.976	13.2	31.46
甲烷 Methane	CH4	16.043	52.86	0.7167	0.668	0.5544	111.7	1.315*	190.7	47.3	162
乙烷 Ethane	C2H6	30.07	28.20	1.3567	1.263	1.0494	184.52	1.18*	305.45	49.8	203
丙烷 Propane	C3H8	44.097	19.23	2.005	1.867	1.5509	231.05	1.13*	369.96	43.4	220
正丁烷 Normal butane	C4H10	58.124	14.59	2.703		2.091	272.65	1.10*	425.15	38.71	228
异丁烷 Isobutane	C4H10	58.124	14.59	2.675		2.0692	261.45	1.11*	408.15	37.2	222
正戊烷 N-pentane	C5H12	72.151	11.75	3.215		2.4869	309.25	1.07*	469.75	34.34	244
乙烯 Ethylene	C2H4	28.054	30.23	1.2604	1.174	0.975	169.45	1.22	283.05	51.6	227
丙烯 Propylene	C3H6	42.081	20.15	1.914	1.784	1.48	225.45	1.15*	365.05	47.1	233
丁烯-1 Butene-1	C4H8	56.108	15.11	2.500		1.9338*	266.85	1.11*	419.15	40.99	233
顺丁烯-2 Maleic-2	C4H8	56.108	15.11	2.500		1.9338*	276.85	1.1214*	433.15	42.89	238
反丁烯-2 Reverse butene-2	C4H8	56.108	15.11	2.500		1.9338*	274.05	1.1073*	428.15	41.83	238
异丁烯 Isobutylene	C4H8	56.108	15.11	2.500		1.9338*	266.25	1.1068*	417.85	40.77	234
乙炔 Acetylene	C2H2	26.038	32.57	1.1717	1.091	0.9063	188.13(附物)	1.24	309.15	63.7	231
苯 Benzene	C6H6	78.114	10.86	3.3		2.553	353.25	1.101	562.15	50.19	304
一氧化碳 Carbon monoxide	CO	28.0106	30.27	1.2584	1.165	0.9672	81.65	1.395	132.92	35.6	301
二氧化碳 Two carbon dioxide	CO2	44.00995	19.27	1.977	1.842	1.5291	194.75(附物)	1.295	304.19	75.28	468
氧化氮 Nitrogen oxide	NO	30.0061	28.26	1.3401		1.0366	121.45	1.4	179.15	66.1	52
二氧化氮 Nitrogen dioxide	NO2	46.0055	18.43	2.055		1.59	294.35	1.31	431.35	103.3	570
一氧化二氮 Nitrous oxide	N2O	44.0128	19.27	1.9781		1.530	184.66	1.274	309.71	74.1	457
硫化氢 Hydrogen sulfide	H2S	34.07994	24.88	1.539	1.434	1.1904	212.85	1.32	373.55	91.8	373
氢氰酸 Hydrocyanic acid	HCN	27.0258	31.38	1.2246		0.947(3℃)	298.85	1.31(65℃)	456.85	54.8	200
臭氧 Ozone	O3	60.0746	14.12	2.712		2.105	222.95		378.15	63	
二氧化硫 Sulfur dioxide	SO2	64.0628	13.24	2.727	2.726	2.264	263.15	1.25	430.65	80.4	524
氟 Fluorine	F2	37.9968	22.32	1.695		1.31	85.03	1.358	172.15	56.8	473
氯 Chloride	Cl2	70.906	11.96	3.214	3.00	2.486	238.55	1.35	417.15	78.6	573
氯甲烷 Chloride methane	CH3Cl	50.488	16.8	2.3044		1.782	249.39	1.28	416.15	68.1	353
氯乙烷 Chloroethane	C2H5Cl	64.515	13.14	2.870		2.22	285.45	1.19	455.95	53.7	330
氨 Ammonia	NH3	17.0306	49.79	0.771	0.719	0.5964	239.75	1.32	405.65	115.0	235
氟里昂-11 Chloride Lyon-11	CCl3F	137.3686	6.17	6.20		4.8	296.95	1.135	471.15	44.6	554
氟里昂-12 Chloride Lyon-12	CCl2F2	120.914	7.01	5.39		4.17	243.35	1.138	385.15	40.0	558
氟里昂-13 Chloride Lyon-13	CClF3	104.4594	8.12	4.654		3.6	191.75	1.15(10℃)	302.05	39.4	578
氟里昂-113 Chloride Lyon-113	CCl2FCF3	187.3765	4.53	8.274		6.4	320.75		487.25	34.80	576

*15.6℃时的值 *15.6℃ of value

液体的性质表 The nature of the liquid table

名称 Name	分子式 Molecular formula	分子量 Molecular weight	密度 ρ ₂₀ (kg/mm ³) 在20℃时 Density ρ ₂₀ (kg/mm ³) At 20°C when	沸点 ρ _b (°C)在760 mmHg时 Boiling point ρ _b (°C) in 760 mmHg in	临界点 Critical point			体积膨胀 系数 μ * 105(1/°C) Volume expansion Factor μ * 105(1/°C)
					温度 T _c K Temperature	压力 P _c kgf/cm ² Pressure	密度 ρ _c kg/m ³ Density	
水 Water	H ₂ O	18.0	998.2	100.00	374.15	225.65	307	18
水银 Mercury	Hg	200.6	13545.7	365.95	1460	107.6	5000	18.1
溴 Bromide	Br ₂	159.8	3120	58.8	311	105.4	1180	113
硫酸 Sulfuric acid	H ₂ SO ₄	98.1	1834	340分解 decomposition				57
硝酸 Nitric acid	HNO ₃	63.0	1512					124
盐酸(30%) Hydrochloric acid	HCl	36.47	1149.3					
环丁矾 Ring butyl alum	C ₄ H ₈ O ₂	120	1261(30°C)	285				
丙酮 Acetone	CH ₃ COCH ₃	58.08	791	56.2	235	48.6	268	143
甲乙酮 Methyl ethyl ketone	CH ₃ COCH ₂ H ₅	72.11	803	79.6	260	39.5		
酚 Phenol	C ₆ H ₅ OH	94.1	1050(50°C)	803	419	62.6		
二硫化碳 Carbon disulfide	CS ₂	76.13	1282	46.3	277.7	75.5	440	119
乙醇胺 Ethanolamine	NH ₂ CH ₂ CH ₂ OH	61.1		170.5				
甲醇 Methanol	CH ₃ OH	32.04	791.3	64.7	240	81.3	272	119
乙醇 Ethanol	C ₂ H ₅ OH	46.07	789.2	78.3	243.1	64.4	275.5	110
乙二醇 Glycol	C ₂ H ₄ (OH) ₂	62.1	1113	197.6				
正丙醇 Normal propyl alcohol	CH ₃ CH ₂ CH ₂ OH	60.10	804.4	97.2	265.8	51.8	273	98
异丙醇 Isopropyl alcohol	CH ₃ CH(OH)CH ₃	60.10	785.1	82.2	273.5	54.9	274	
正丁醇 Normal butanol	CH ₃ CH ₂ CH ₂ CH ₂ OH	74.12	809.6	117.8	287.1	50.2		
乙氧 Boyanide	C ₂ H ₅ ON	41	783	81.6	274.7	49.2	240	
正戊醇 Amyl alcohol	CH ₃ CH ₂ CH ₂ CH ₂ CH ₂ OH	88.15	813.0	138.0	315.0			88
乙醛 Acetaldehyde	CH ₃ CHO	44.05	783	20.2	188.0			
丙醛 Propanal	CH ₃ CH ₂ CHO	58.08	808	48.9				
环己酮 Cyclohexanone	C ₆ H ₁₀ O	98.15	946.6	155.7				
二乙醚 Diethyl ether	(C ₂ H ₅) ₂ O	74.12	714	34.6	194.7	37.5	264	162
甘油 Glycerin	C ₃ H ₅ (OH) ₃	92.09	1261.3	200分解 decomposition				50
邻甲酚 O-cresol	C ₆ H ₄ (OH)CH ₃	108.14	1020(50°C)	191.0	422.3	51.1		
间甲酚 Metacresol	C ₆ H ₄ (OH)CH ₃	108.14	1034.1	202.2	432.0	46.5		
对甲酚 P-cresol	C ₆ H ₄ (OH)CH ₃	108.14	1011(50°C)	202.0	426.0	52.6		
甲酸甲酯 Methyl formate	CH ₃ COOCH ₃	60.05	975	31.8	212.0	61.1	349	121
醋酸甲酯 Methyl acetate	CH ₃ COOCH ₃	74.08	934	57.1	235.8	47.9		
丙酸甲酯 Propionic acid methyl ester	CH ₃ COOCH ₂ H ₅	88.11	915	79.7	261.0	40.8		
甲酸 Formic acid	HCOOH	46.03	1220	100.7				102
乙酸 Acetic acid	CH ₃ COOH	60.05	1049	118.1	312.5	59		
丙酸 Propionic acid	C ₂ H ₅ COOH	74.08	993	141.3	339.5	54.1	320	109
苯胺 Aniline	C ₆ H ₅ NH ₂	93.13	1021.7	184.4	425.7	54.1	340	85
丙烯 Acrylic nitrile	C ₃ H ₃ N	55.08	781.8	97.2	291.2	42.8		
丁腈 Nitrile	C ₄ H ₇ N	69.11	790	117.6	309.1	38.6		
酰胺 Acyl oomand	(CH ₂) ₂ (CH) ₂	94.14	1065	84.1	317.3	49.3		
二氯甲烷 Methylene chloride	CH ₂ Cl ₂	84.93	1325.5	40.1	237.5	62.9		
氯仿 Chloride letter	CHCl ₃	119.38	1490	61.2	260.0	55.6	496	128
四氯化碳 Carbon tetrachloride	CCl ₄	153.82	1594	76.8	283.2	46.5	558	122
邻二甲苯 O-xylene	C ₈ H ₁₀	106.16	880	177	358.1	38.1		97
间二甲苯 M-xylene	C ₈ H ₁₀	106.16	864	139.2	346	37.2		99
对二甲苯 P-xylene	C ₈ H ₁₀	106.16	861	138.1	345	36.1		102
甲苯 Toluene	C ₇ H ₈	92.1	866	110.7	320.6	43.0	290	108
邻氯甲苯 O-chlorotoluene	C ₇ H ₇ Cl	126.6	1081	159				89
间氯甲苯 Chlorotoluene between	C ₇ H ₇ Cl	126.6	1072	162				
环己烷 Cyclohexane	C ₆ H ₁₂	84.1	778	80.8	280	41.3	273	120
己烷 Hexane	C ₆ H ₁₄	86.2	680	68.73	234.7	30.9	234	135
庚烷 Sthane confirmed	C ₇ H ₁₆	100.2	684	96.1	267.0	27.9	235	124
辛烷 Octane	C ₈ H ₁₈	111.2	702	125.7	296.7	25.4	233	114

材料选用表 Material selection table

流体 Flow body	材 料 Wood material													
	碳钢 Carbon steel	铸铁 Cast Iron	302或 304 不锈钢 Stainless steel	316 不锈钢 Stainless steel	青铜 bronze	蒙乃尔 合金 monel alloy	哈氏 合金 B He's alloy B	哈氏 合金 C He's alloy C	不锈钢 # 20 Stainless steel # 20	钛 Titanium	钴铬 合金 # 6 Cobalt chromium alloy # 6	416 不锈钢 Stainless steel	440C 不锈钢 Stainless steel	17-4 PH 不锈钢 17-4 PH Stainless steel
乙醛 Acetaldehyde	A	A	A	A	A	A	I.L	A	A	I.L	I.L	A	A	A
醋酸(无气的) Acetic acid (no gas)	C	C	B	B	B	B	A	A	A	A	A	C	C	B
醋酸(无气的) Acetic acid (inflatable)	C	C	A	A	A	A	A	A	A	A	A	C	C	B
醋酸蒸气 Acetic acid steam	C	C	A	A	B	B	I.L	A	B	A	A	C	C	B
丙酮 Acetone	A	A	A	A	A	A	A	A	A	A	A	A	A	A
乙酸 Acetylene	A	A	A	A	I.L	A	A	A	A	I.L	A	A	A	A
乙醇 Ethanol	A	A	A	A	A	A	A	A	A	A	A	A	A	A
硫酸铝 Aluminum sulfate	C	C	A	A	B	B	A	A	A	A	I.L	C	C	I.L
氨 Ammonia	A	A	A	A	C	A	A	A	A	A	A	A	A	I.L
氯化铵 Ammonium chloride	C	C	B	B	B	B	A	A	A	A	B	C	C	I.L
硝酸铵 Ammonium nitrate	A	C	A	A	C	C	A	A	A	A	A	C	B	I.L
磷酸(一价的) Ammonium phosphate (a price)	C	C	A	A	B	B	A	A	A	A	A	B	B	I.L
硫酸铵 Ammonium sulfate	C	C	B	A	B	A	A	A	A	A	A	C	C	I.L
亚硫酸铵 Ammonium bisulfite	C	C	A	A	C	C	I.L	A	A	A	A	B	B	I.L
苯胺 Aniline	C	C	A	A	A	B	A	A	A	A	A	C	C	I.L
沥青 Asphalt	A	A	A	A	A	A	A	A	A	I.L	A	A	A	A
啤酒 Beer	B	B	A	A	B	A	A	A	A	A	A	B	B	A
苯 Benzene	A	A	A	A	A	A	A	A	A	A	A	A	A	A
苯甲酸 Benzoic acid	C	C	A	A	A	A	I.L	A	A	A	I.L	A	A	A
硼酸 Boric acid	C	C	A	A	A	A	A	A	A	A	A	B	B	I.L
丁烷 Butane	A	A	A	A	A	A	A	A	A	I.L	A	A	A	A
氯化钙(碱的) Calcium chloride (base)	B	B	C	B	C	A	A	A	A	A	I.L	C	C	I.L
次氯酸钙 Calcium hypochlorite	C	C	B	B	B	B	C	A	A	A	I.L	C	C	I.L
石炭酸 Phenol	B	B	A	A	A	A	A	A	A	A	A	I.L	I.L	I.L
二氧化碳(干的) Carbon dioxide (dry)	A	A	A	A	A	A	A	A	A	A	A	A	A	A
二氧化碳(湿的) Carbon dioxide (wet)	C	C	A	A	A	A	A	A	A	A	A	A	A	A
二硫化碳 Carbon disulfide	A	A	A	A	C	B	A	A	A	A	A	B	B	I.L
四氯化碳 Four hydrogenated carbon	B	B	B	B	A	A	B	A	A	A	I.L	C	A	I.L
碳酸 Carbonic acid	C	C	B	B	B	A	A	A	A	I.L	I.L	A	A	A
氯, 气体(干的) Chlorine, gas (dry)	A	A	B	B	B	A	A	A	A	C	B	C	C	C
氯, 气体(湿的) Chlorine, gas (wet)	C	C	C	C	C	C	C	B	C	C	B	C	C	C
液氯 Liquid chlorine	C	C	C	C	B	C	C	A	C	A	B	C	C	C
铬酸 Chromic acid	C	C	C	B	C	A	C	A	C	A	B	C	C	C
柠檬酸 Citric acid	I.L	C	B	A	A	B	A	A	A	A	I.L	B	B	B
焦炭气 Coke oven gas	A	A	A	A	B	A	A	A	A	A	A	A	A	A
硫酸铜 Copper sulfate	C	C	B	B	B	C	I.L	A	A	A	I.L	A	A	A
棉子油 Cotton seed oil	A	A	A	A	A	A	A	A	A	A	A	A	A	A
桉油油 Creosote	A	A	A	A	A	A	A	A	A	I.L	A	A	A	A
乙烷 Ethane	A	A	A	A	A	A	A	A	A	A	A	A	A	A
乙醚 Ether	B	B	A	A	A	A	A	A	A	A	A	A	A	A
氯乙烷 Chloroethane	C	C	A	A	A	A	A	A	A	A	A	B	B	I.L
乙烯 Ethylene	A	A	A	A	A	A	A	A	A	A	A	A	A	A
乙二醇 Glycol	A	A	A	A	A	A	I.L	I.L	A	I.L	A	A	A	A
氯化铁 Ferric chloride	C	C	C	C	C	C	C	B	C	A	B	C	C	I.L
甲醛 Formaldehyde	B	B	A	A	A	A	A	A	A	A	A	A	A	A

流体 Flow body	材 料 Wood material												
	碳钢 Carbon steel	铸铁 Cast iron	302或304 不锈钢 302 or 304 Stainless steel	316 不锈钢 316 Stainless steel	青铜 bronze	蒙乃尔 合金 monel alloy	哈氏合金 B He's alloy B	哈氏合金 C He's alloy C	不锈钢 # 20 Stainless steel # 20	钛 Titanium	钴铬合金 # 6 Cobalt chromium alloy # 6	416 不锈钢 416 Stainless steel	440C 不锈钢 440 C Stainless steel
甲酸 Formic acid	I.L	C	B	B	A	A	A	A	C	B	C	C	B
氟里昂(湿的) Freon(wet)	B	B	B	A	A	A	A	A	A	A	I.L	I.L	I.L
氟里昂(干的) Freon(dry)	B	B	A	A	A	A	A	A	A	A	I.L	I.L	I.L
糖醛 Sugar aldehyde	A	A	A	A	A	A	A	A	A	A	B	B	I.L
汽油(精制的) Gasoline (refined)	A	A	A	A	A	A	A	A	A	A	A	A	A
葡萄糖 Glucose	A	A	A	A	A	A	A	A	A	A	A	A	A
盐酸(充气的) Hydrochloric acid(inflatable)	C	C	C	C	C	C	A	B	C	B	C	C	C
盐酸(无气的) Hydrochloric acid(no gas)	C	C	C	C	C	C	A	B	C	B	C	C	C
氢氟酸(充气的) Hydrofluoric acid(inflatable)	B	C	C	B	C	C	A	A	B	C	B	C	C
氢氟酸(无气的) Hydrofluoric acid(no gas)	A	C	C	B	C	A	A	B	C	I.L	C	C	I.L
氢 Hydrogen	A	A	A	A	A	A	A	A	A	A	A	A	A
过氧化氢 Hydrogen peroxide	I.L	A	A	A	C	A	B	B	A	I.L	B	B	I.L
硫化氢(液体) Hydrogen sulfide (liquid)	C	C	A	A	C	C	A	B	A	A	C	C	I.L
氢氧化镁 Magnesium hydroxide	A	A	A	A	B	A	A	A	A	A	A	A	I.L
汞 Mercury	A	A	A	A	C	B	A	A	A	A	A	A	B
甲醇 Methanol	A	A	A	A	A	A	A	A	A	A	A	B	A
甲乙酮 Methyl ethyl ketone	A	A	A	A	A	A	A	A	I.L	A	A	A	A
牛奶 Milk	C	C	A	A	A	A	A	A	A	A	C	C	C
天然气 Gas	A	A	A	A	A	A	A	A	A	A	A	A	A
硝酸 Nitric acid	C	C	A	B	C	C	B	A	A	C	C	C	B
油酸 Oleic acid	C	C	A	A	B	A	A	A	A	A	B	B	I.L
草酸 Oxalic acid	C	C	B	B	B	B	A	A	A	B	B	B	I.L
氧 Oxygen	A	A	A	A	A	A	A	A	A	A	A	A	A
石油(精制的) Oil (refined)	A	A	A	A	A	A	A	A	A	A	A	A	A
磷酸(充气的) Phosphate (inflatable)	C	C	A	A	C	C	A	A	B	A	C	C	I.L
磷酸(无气的) Phosphate (no gas)	C	C	A	A	C	B	A	A	B	A	C	C	I.L
磷酸蒸气 Phosphate steam	C	C	B	B	C	C	A	I.L	A	B	C	C	I.L
苦味酸 Picric acid	C	C	A	A	C	C	A	A	I.L	I.L	B	B	I.L
氯化钾 Potassium chloride	B	B	A	A	B	B	A	A	A	I.L	C	C	I.L
氢氧化钾 Potassium hydroxide	B	B	A	A	B	A	A	A	A	I.L	B	B	I.L
丙烷 Propane	A	A	A	A	A	A	A	A	A	A	A	A	A
松香 Rosin	B	B	A	A	A	A	A	A	I.L	A	A	A	A
硝酸银 Silver nitrate	C	C	A	A	C	C	A	A	A	B	B	B	I.L
醋酸钠 Sodium acetate	A	A	B	A	A	A	A	A	A	A	A	A	A
碳酸钠 Sodium carbonate	A	A	A	A	B	A	A	A	A	A	B	B	A
氯化钠 Sodium chloride	C	C	B	B	A	A	A	A	A	A	B	B	B
铬酸钠 Sodium chromate	A	A	A	A	A	A	A	A	A	A	A	A	A
氢氧化钠 Sodium hydroxide	A	A	A	A	C	A	A	A	A	A	A	B	A
次氯酸钠 Sodium hypochlorite	C	C	C	C	B-C	B-C	C	A	B	A	I.L	C	I.L
硫代硫酸钠 Sodium thiosulfate	C	C	A	A	C	C	A	A	A	I.L	B	B	I.L

流体 Flow body	材 料 Wood material													
	碳钢 Carbon steel	铸铁 Cast iron	302或304 不锈钢 302 or 304 Stainless steel	316 不锈钢 316 Stainless steel	青铜 bronze	蒙乃尔 合金 monel alloy	哈氏合金 B He's alloy B	哈氏合金 C He's alloy C	不锈钢 # 20 Stainless steel # 20	钛 Titanium	钴铬合金 # 6 Cobalt chromium alloy # 6	416 不锈钢 416 Stainless steel	440C 不锈钢 440 C Stainless steel	17-4 PH 不锈钢 17-4 PH Stainless steel
氯化亚锡 Stannous chloride	B	B	C	A	C	B	A	A	A	A	I.L	C	C	I.L
硬脂酸 Stearic acid	A	C	A	A	B	B	A	A	A	A	B	B	B	I.L
硫酸盐溶液(黑的) Sulfate solution (black)	A	A	A	A	C	A	A	A	A	A	A	I.L	I.L	I.L
硫 Sulfur	A	A	A	A	C	A	A	A	A	A	A	A	A	A
二氧化硫(干的) Sulfur dioxide (dry)	A	A	A	A	A	A	B	A	A	A	B	B	B	I.L
三氧化碳(干的) Three oxidation carbon (dry)	A	A	A	A	A	A	B	A	A	A	B	B	B	I.L
硫酸(充气的) Sulfuric acid (inflatable)	C	C	C	C	C	C	A	A	A	B	B	C	C	C
硫酸(无气的) Sulfuric acid (no gas)	C	C	C	C	B	B	A	A	A	B	B	C	C	C
亚硫酸 Sulfurous acid	C	C	B	B	B	C	A	A	A	A	B	C	C	I.L
焦油 Tar	A	A	A	A	A	A	A	A	A	A	A	A	A	A
三氯乙烯 Trichloroethylene	B	B	B	A	A	A	A	A	A	A	A	B	B	I.L
松节油 Turpentine	B	B	A	A	A	B	A	A	A	A	A	A	A	A
醋 Vinegar	C	C	A	A	B	A	A	A	A	I.L	A	C	C	A
水(锅炉给水) Water(boiler feed water)	B	C	A	A	C	A	A	A	A	A	A	B	A	A
水(蒸馏的) Water(distillation)	A	A	A	A	A	A	A	A	A	A	A	B	B	I.L
海水 Seawater	B	B	B	B	A	A	A	A	A	A	A	C	C	A
威士忌酒和啤酒 Whisky is separated and wine	C	C	A	A	A	B	A	A	A	A	A	C	C	I.L
氯化锌 Zinc chloride	C	C	C	C	C	C	A	A	A	A	B	C	C	I.L
硫酸锌 Zinc sulfate	C	C	A	A	B	A	A	A	A	A	B	B	B	I.L

符号: A—能够或正被成功地应用

B—应用过程应注意

C—不能应用

I.L—缺乏资料

本表是用来大致指出与某种流体接触而发生反应时, 应如何选择适当的材料。表中的推荐不是绝对的, 因为材料的耐腐蚀性与流体的浓度、温度、压力和杂质等因素有关。因此, 必须强调本表只能作为一个导则。

材料中—英文对照表

- 蒙乃尔合金
- 哈氏合金B(C)
- 不锈钢#20
- 钴-铬合金#6

Symbol: A—can or are being successfully applied

B—application process should pay attention to

C—cannot be applied

I.L—lack of material

This form is used to roughly pointed out and some fluid contact reaction, Should how to choose appropriate material. Recommended in the table is not absolute, because wood Material corrosion resistance and fluid concentration, temperature, pressure and impurity factors Relevant. Therefore, we must emphasize that this form can only as a guideline.

Materials—English table

- Monel
- Hastelloy *B*(C)
- Durimet 20
- Alloy 6(Co-Cr)